

3J Gen 2.0 Vehicle Display Controller + Joystick Controller Modules J1939/CAN User Manual

Grayhill PN: 3JUM1965-1

Revisions

| Revision | Description | Checked / Approved |
|----------|--|-----------------------|
| A | Original. ECN#414854 JAA 4-24-2018 | BMM/JLF 5-1-2018 |
| B | Changed LED STAT PGNs to Prop B Updated names of LOW POWER parameters Changed default values for various parameters Added BUTTON PGN SECONDARY parameter Added Appendix C JAA 8-9-2018 ECN#415809 | JLF/RAL 8/20/2018 |
| C | Added details about Proportional Error States Added encoder configuration parameters similar to Gen 1 in Section 5.5.12. Misc. code updates. 3JUM1965-1 Revision C applies to firmware revisions: Boot Loader: 3JPR1973-1 Rev B Digital Joystick / Encoder only: 3JPR1974-1 Rev B Single Proportional: 3JPR1974-2 Rev A Dual Proportional: 3JPR1974-3 Rev A JLF 11/26/2019 ECN#420806 | JJS/RAL 11/26/2019 |



An ISO-9001 Company

Table of Contents

| | |
|---|----|
| 1. Overview..... | 5 |
| 1.1. Reference Documents | 5 |
| 2. VDC + Joystick Controller Operation | 5 |
| 2.1. Joystick Controller Operation | 6 |
| 2.2. Digital Joystick and Rotary Encoder Operation | 7 |
| 2.3. Modes of Operation..... | 7 |
| 2.3.1. Initial Power-Up..... | 7 |
| 2.3.2. Run..... | 7 |
| 2.3.3. Low Power | 7 |
| 2.3.4. Demo..... | 8 |
| 2.4. CAN FD Tolerant Feature | 9 |
| 3. Diagnostics | 9 |
| 3.1. Key Diagnostics | 9 |
| 3.2. LED Indicator Diagnostics..... | 9 |
| 3.3. Joystick Controller and VDC Diagnostics | 9 |
| 3.3.1. Joystick Controller..... | 9 |
| 3.3.2. Digital Joystick and Encoder..... | 10 |
| 4. Joystick Controller and VDC Configuration..... | 10 |
| 4.1. Reading..... | 10 |
| 4.1.1. Example | 10 |
| 4.2. Writing..... | 10 |
| 4.2.1. Example | 10 |
| 4.3. Parameter List..... | 11 |
| 4.3.1. ECUID Part Number ID=0x00, Size <= 64 | 11 |
| 4.3.2. ECUID Location ID=0x01, Size <= 64 | 11 |
| 4.3.3. ECUID Type ID=0x02, Size<= 64..... | 11 |
| 4.3.4. ECUID Manufacturer ID=0x03, Size<= 64..... | 11 |
| 4.3.5. Component ID Make ID=0x04, Size <=5..... | 11 |
| 4.3.6. Component ID Model ID=0x05, Size<= 64..... | 11 |
| 4.3.7. Component ID Serial Number ID=0x06, Size<= 64..... | 11 |
| 4.3.8. Component ID Unit Number ID=0x07, Size<= 64 | 11 |
| 4.3.9. J1939 Name Identification ID=0x08, Size = 4 | 11 |
| 4.3.10. J1939 Name Manufacturer Code ID=0x09, Size = 2 | 11 |
| 4.3.11. J1939 Name ECU Instance ID=0x0A, Size = 1 | 11 |
| 4.3.12. J1939 Name Function Instance ID=0x0B, Size = 1 | 12 |
| 4.3.13. J1939 Name Function ID=0x0C, Size = 1..... | 12 |
| 4.3.14. J1939 Name Vehicle System ID=0x0D, Size = 1..... | 12 |
| 4.3.15. J1939 Name Vehicle System Instance ID=0x0E, Size = 1 | 12 |
| 4.3.16. J1939 Name Industry Group ID=0x0F, Size = 1 | 12 |
| 4.3.17. J1939 Name Arbitrary Address Capable ID=0x10, Size = 1..... | 12 |
| 4.3.18. Button PGN ID=0x11, Size = 4 | 12 |
| 4.3.19. Button Priority ID=0x12, Size = 1 | 12 |
| 4.3.20. Button Send On Event ID=0x13, Size = 1..... | 12 |
| 4.3.21. Button Transmit Period ID=0x14, Size = 1..... | 12 |
| 4.3.22. Indicator Status 1 PGN ID=0x15, Size = 4..... | 13 |
| 4.3.23. Indicator Status 2 PGN ID=0x16, Size = 4..... | 13 |
| 4.3.24. Indicator Status PRI ID=0x17, Size = 1..... | 13 |
| 4.3.25. Indicator Status Send On Event ID=0x18, Size = 1 | 13 |
| 4.3.26. Indicator Status Transmit Period ID=0x19, Size = 1 | 13 |
| 4.3.27. Diagnostic Blink Period ID=0x1A, Size = 1 | 13 |
| 4.3.28. LED COMM Timeout Period ID=0x1B, Size = 1 | 13 |
| 4.3.29. LED Stuffing Configuration 1 ID=0x1C, Size = 3 | 13 |

| | | | |
|---------|--|--------------------|----|
| 4.3.30. | LED Stuffing Configuration 2 | ID=0x1D, Size = 3 | 14 |
| 4.3.31. | Default Indicator Intensity | ID=0x1E, Size = 1 | 14 |
| 4.3.32. | Default Backlight Intensity | ID=0x1F, Size = 1 | 14 |
| 4.3.33. | Stuck Button Error Timeout Period | ID=0x20, Size = 1 | 14 |
| 4.3.34. | LED PWM BASE 1 | ID=0x21, Size = 24 | 14 |
| 4.3.35. | LED IREF BASE 1 | ID=0x22, Size = 24 | 14 |
| 4.3.36. | LED PWM BASE 2 | ID=0x23, Size = 24 | 14 |
| 4.3.37. | LED IREF BASE 2 | ID=0x24, Size = 24 | 14 |
| 4.3.38. | DEVICE CONFIG | ID=0x25, Size = 2 | 15 |
| 4.3.39. | FLEXIO CONFIG | ID=0x26, Size = 1 | 15 |
| 4.3.40. | Demo Mode | ID=0x27, Size = 1 | 15 |
| 4.3.41. | Baud Rate | ID=0x28, Size = 1 | 15 |
| 4.3.42. | AUXIO1 Priority | ID=0x29, Size = 1 | 15 |
| 4.3.43. | AUXIO1 Send On Event | ID=0x2A, Size = 1 | 16 |
| 4.3.44. | AUXIO1 Tx Period | ID=0x2B, Size = 1 | 16 |
| 4.3.45. | Low Power Delay Period | ID=0x2C, Size = 1 | 16 |
| 4.3.46. | Low Power Wake Signal Period | ID=0x2D, Size = 1 | 16 |
| 4.3.47. | Low Power Config | ID=0x2E, Size = 1 | 16 |
| 4.3.48. | Diag Reporting Config | ID=0x2F, Size = 1 | 16 |
| 4.3.49. | Source Address | ID=0x30, Size = 1 | 17 |
| 4.3.50. | Source Address Save | ID=0x31, Size = 1 | 17 |
| 4.3.51. | Brightness Control Configuration | ID=0x32, Size = 1 | 17 |
| 4.3.52. | Encoder Type | ID=0x33, Size = 1 | 17 |
| 4.3.53. | Encoder Counter Max | ID=0x34, Size = 2 | 17 |
| 4.3.54. | Encoder Counter Rollover | ID=0x35, Size = 1 | 17 |
| 4.3.55. | Button PGN Secondary | ID=0x36, Size = 3 | 17 |
| 5. | Communications | | 18 |
| 5.1. | Message Header Description | | 18 |
| 5.1.1. | Priority | | 18 |
| 5.1.2. | DP (Data Page) | | 18 |
| 5.1.3. | Protocol Data Unit (PDU) - PDU Format (PF) | | 18 |
| 5.1.4. | Protocol Data Unit (PDU) - PDU Specific (PS) | | 18 |
| 5.1.5. | Source Address | | 18 |
| 5.1.6. | Parameter Group Number | | 19 |
| 5.2. | Bit-field Location and Byte Ordering | | 19 |
| 5.3. | Joystick Controller and VDC Source Address | | 19 |
| 5.4. | Physical Layer | | 20 |
| 5.5. | Standard PGNs | | 20 |
| 5.5.1. | AUXIO 2 (Indicator Set 1) | 42752 (0xA700) | 20 |
| 5.5.2. | Cab Illumination | 53248 (0xD000) | 21 |
| 5.5.3. | Memory Access Request (DM14) | 55552 (0xD900) | 21 |
| 5.5.4. | Memory Access Response (DM15) | 55296 (0xD800) | 21 |
| 5.5.5. | Binary Data Transfer (DM16) | 55040 (0xD700) | 21 |
| 5.5.6. | Boot Load Data (DM17) | 54784 (0xD600) | 21 |
| 5.5.7. | Acknowledgement Message | 59392 (0xE800) | 22 |
| 5.5.8. | PGN Request | 59904 (0xEA00) | 22 |
| 5.5.9. | Transport Protocol Data Transfer | 60160 (0xEB00) | 22 |
| 5.5.10. | Transport Protocol Connection Mgmt | 60416 (0xEC00) | 22 |
| 5.5.11. | Address Claimed | 60928 (0xEE00) | 23 |
| 5.5.12. | Prop A (Normal Mode) | 61184 (0xEF00) | 24 |
| 5.5.13. | Prop A (Configuration Mode*) | 61184 (0xEF00) | 25 |
| 5.5.14. | ECU Identification Information | 64965 (0xFDC5) | 25 |
| 5.5.15. | Active Diagnostic Trouble Codes (DM1) | 65226 (0xFECA) | 25 |
| 5.5.16. | Previously Active Trouble Codes (DM2) | 65226 (0xFECB) | 26 |
| 5.5.17. | Clear/Reset of Previously Active DTCs (DM3) | 65227 (0xFECC) | 26 |



| | | | |
|---------|--|----------------|----|
| 5.5.18. | Clear/Reset of Active DTCs (DM11) | 65235 (0xFED3) | 26 |
| 5.5.19. | Commanded Address | 65240 (0xFED8) | 27 |
| 5.5.20. | Software Identification | 65242 (0xFEDA) | 27 |
| 5.5.21. | Component ID | 65259 (0xFEEB) | 27 |
| 5.5.22. | Digital Joystick and Rotary Encoder VDC Specific | | 28 |
| 5.5.23. | Joystick Controller Specific | | 29 |
| 5.5.24. | Prop B (Indicator Set 1 Status) | 65447 (0xFFA7) | 32 |
| 6. | APPENDIX | | 33 |
| 6.1. | Appendix A Diagnostic Trouble Codes | | 33 |
| 6.2. | Appendix B Device Configuration Parameters | | 34 |
| 6.3. | Appendix C Behavior from Timeout/Low Power Configuration | | 36 |
| 6.4. | Appendix D FAQ and Examples | | 37 |

1. Overview

This document describes the functionality and communication of the Grayhill J1939 CAN-Bus Vehicle Display Controllers Gen 2.0.

1.1. Reference Documents

The following documents are referenced within this document.

- SAE-J1939
- SAE-J1939/11
- SAE-J1939/21
- SAE-J1939/71
- SAE-J1939/81
- ISO-11898-2

2. VDC + Joystick Controller Operation

Gen 2 VDC + Joystick Controllers can be grouped into three basic types depending on whether it has a proportional joystick, a digital joystick, or a rotary encoder. The button and LED indicator locations are shown below, as well as the joystick and encoder operation. Indicator numbers 16, 17, and 18 are skipped, as button 6 does not have indicators.

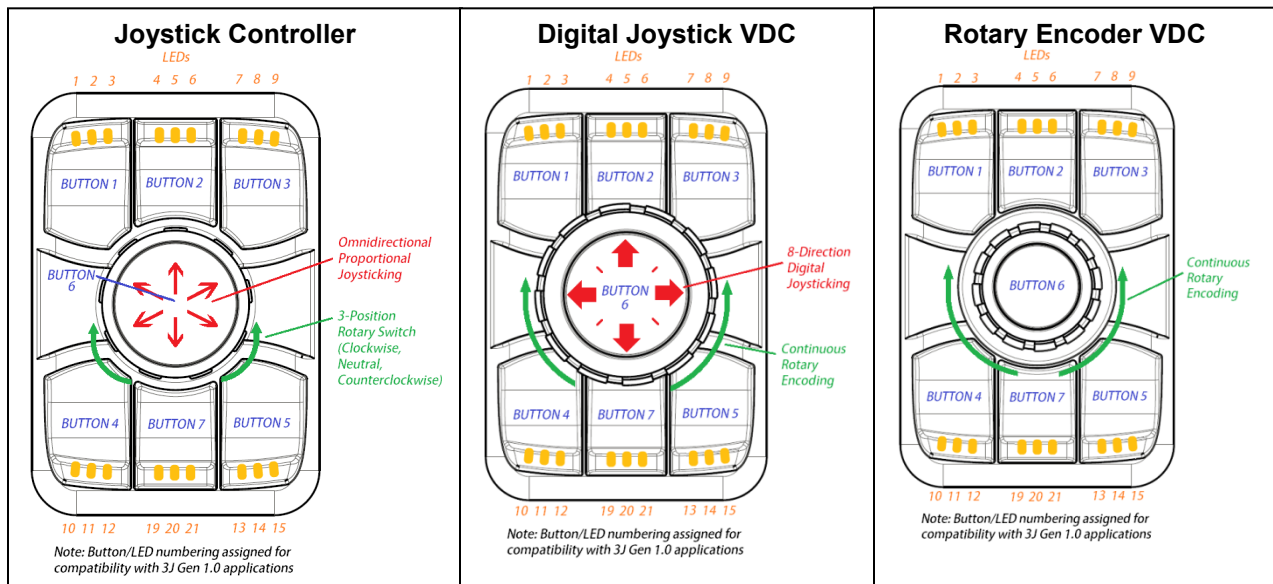

Figure 1 – 3J Gen 2.0 Joystick & VDC Button and Indicator Map

2.1. Joystick Controller Operation

Joystick Controllers feature a proportional joystick. The joystick detects actuation in any direction on the plane parallel to the surface of the keypad. See the image below. The controller expresses the X and Y axis components of the vector of actuation. The vector of actuation has a range of 0 to 1000 units. Example: actuating the joystick to the end of its range at a 45° angle from the X-axis will result in a value of 700 for both the X-axis and Y-axis components, but pressing it directly to the right will result in a magnitude of 1000 on the X-axis and a magnitude of 0 on the Y-axis. Actuation with a low angle of throw is considered to be in the neutral zone and will be reported as having a vector magnitude of 0. Adjacent component vector magnitudes are spaced 20 units apart, so actuation immediately outside of the neutral zone will result in at least one component vector with a magnitude of 20 (the minimum non-zero value).

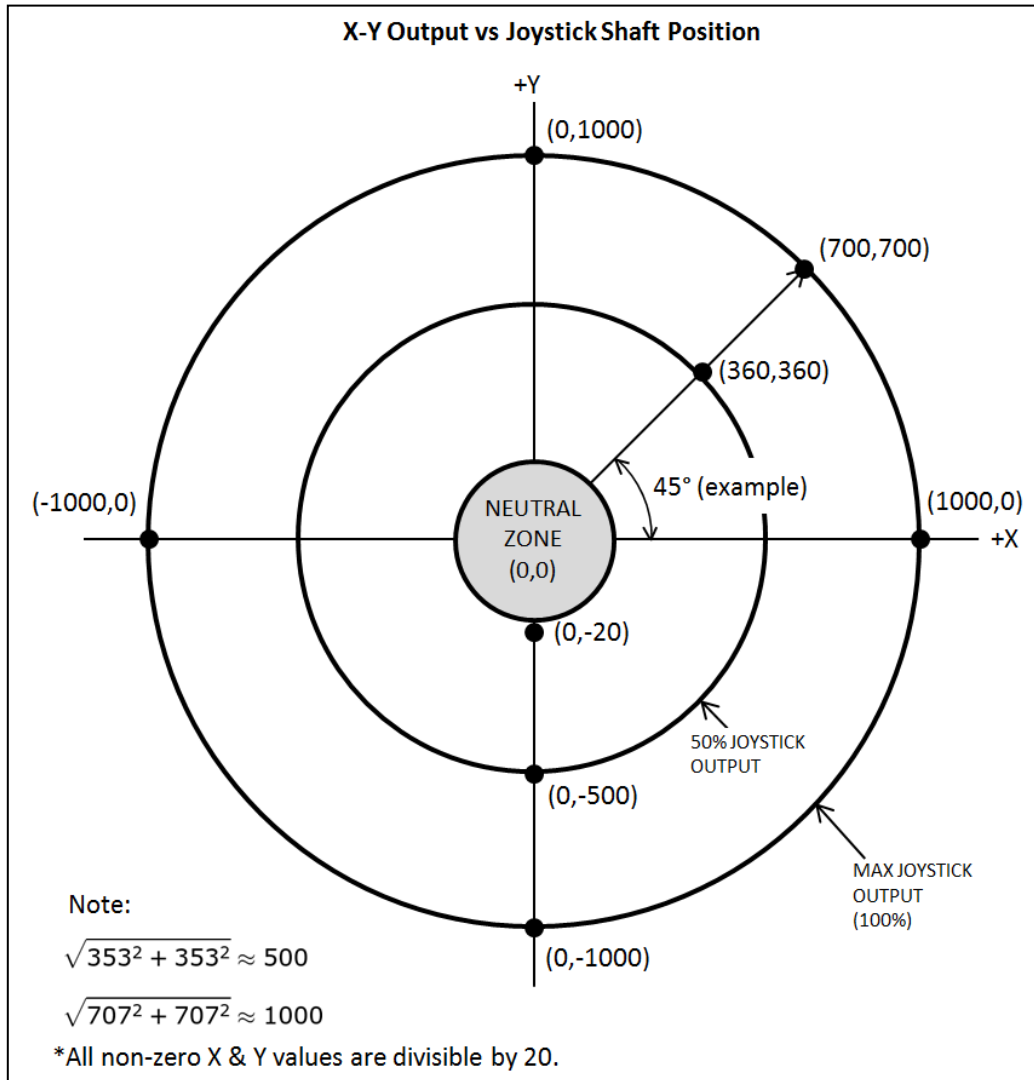

Figure 2 – Joystick Controller Output

The Joystick Controller also features a momentary rotary input that provides a momentary signal indicating clockwise or counterclockwise rotation. This is reported on the CAN bus as part of Basic Joystick Message 1.

2.2. Digital Joystick and Rotary Encoder Operation

For modules with a digital joystick, the joystick is an 8-way sensor. Joystick status is reported via a 2-bit field assigned to each of the cardinal directions (-X, +X, -Y, and +Y). A diagonal actuation is reported as having both an x and a y component. The digital joystick also includes a rotary incremental encoder. In both the digital joystick and rotary encoder VDCs, encoder rotation increments or decrements a counter in the Prop B Digital Joystick/Encoder CAN message.

2.3. Modes of Operation

2.3.1. Initial Power-Up

This state is when the device is first powered up. When this state is entered, all of the peripherals are initialized. The device remains in this state until the supply voltage reaches a minimum where it then transfers to the Run state.

2.3.2. Run

Entering Run mode initiates the J1939 Address Claiming procedure. If the module loses arbitration with another device having the same source address and a lower Name value, it will take one of two actions depending on the state of the Arbitrary Address Capable configuration:

- **AAC Enabled:** Send another Address Claimed message with a new source address until one is found. If all possible source addresses are tested, the device will claim the Cannot Claim Address message.
- **AAC Disabled:** Immediately send the Cannot Claim Address message.

If the Diagnostic Blink is enabled, the device will illuminate all indicators and backlights for the specified amount of time. This serves as a visual indicator that all lamps are operational.

Key, joystick, and encoder information is sent according to its configuration which is either upon an event (key press or release or actuation of the joystick or encoder), a periodic timer, or both. During proportional joystick actuation, it will be sent every 20 ms. Upon an event the corresponding bit locations in the data field are set.

Indicator LEDs are manipulated according to their configuration (blinking, on, off). The module constantly monitors for Configuration and Control Messages and takes action accordingly.

If Low Power mode is enabled, the device will enter Low Power mode when all of the following conditions persist for a configured amount of time (ex. 2 seconds):

- **No Button/Joystick/Encoder Activity**
- **No CAN Traffic**

2.3.3. Low Power

When this state is entered, the device turns off all indicators and backlights and places all peripherals in low power mode. The device will wake with one of the following events:

- **Button Press**
- **CAN Traffic**

From here, the device enters Run. Upon wake-up, the device will send an Address Claimed message.

2.3.4. Demo

If the DEVICE_DEMO_MODE parameter is programmed with a non-zero value less than, demo mode can be entered by powering up the module while simultaneously holding down BTN #1 and BTN #7. The module will blink all LEDs twice to signify that demo mode has been activated, regardless of the LED_DIAG_BLINK_PER parameter setting. Anytime a button is pressed or joystick is actuated in a particular direction the corresponding indicator LED statuses will change. In demo mode the module is still fully functional, except that it will not respond to indicator control CAN commands. To exit demo mode, reset or power cycle the module without holding down the buttons. To make demo mode inaccessible, set DEVICE_DEMO_MODE to 0 and reset the device.

Below is the behavior of the devices when in demo mode.

When the device is in demo mode, repeatedly pressing button 1 takes the device through a cycle of states that determine whether, and how quickly, encoder or rotary switch actuation will change LED brightness.

| State # | Number of button presses (resets to 0 after 4) | State of button 1 indicators | VDC Encoder's effect on backlights (Joystick Controller rotary switch has 1 brightness change speed and it is independent of State #) |
|---------|--|----------------------------------|--|
| 0 | 0 | All off | No effect |
| 1 | 1 | Left on | Changes brightness value by 2 at a time (on a per detent basis for encoders and on a timer basis for the proportional joystick rotary switch). This is quite slow. |
| 2 | 2 | Left and Center on | Changes brightness value by 4 at a time. |
| 3 | 3 | Left, Center, and Right on | Changes brightness value by 6 at a time. |
| 4 | 4 | Left, Center, and Right blinking | Changes brightness value by 8 at a time. This is quite fast. |

| Operator Input | Device Action |
|--|--|
| Proportional joystick actuation | Turns on all indicators for the button that lies closest to the direction of actuation. Sets brightness of these indicators to a value proportional to the magnitude of actuation. Indicators on all other buttons are turned off. |
| Non-proportional joystick actuation | Turns on all indicators for the button that lies closest to the direction of actuation. Indicators on all other buttons are turned off. |
| Encoder actuation (regardless of type) | Clockwise actuation brightens all indicators that are already turned on and all backlights. Counterclockwise actuation dims them. The rate of change depends on the State # in the table above. |
| Button n press | For n = 1, see the above table. For n > 1, the indicator behavior is the same for button n as is described for button 1 in the table above, but the state for brightness control does not change. |

2.4. CAN FD Tolerant Feature

The VDCs utilize the Infineon TLE9255 HS CAN Transceiver to implement the CAN FD Tolerant feature. The FDF Bit of the Control Field of a CAN FD frame identifies the type of CAN frame:

- FDF bit = 1: CAN FD frame recognized, decoding stops
- FDF bit = 0: classical CAN frame recognized, processing of the frame continues

In this way it is possible to send mixed CAN frame formats.

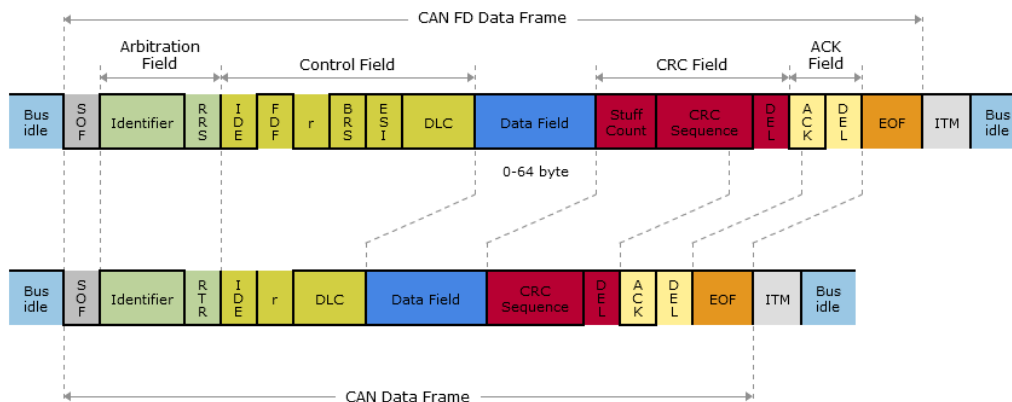

3. Diagnostics

3.1. Key Diagnostics

The VDC uses an alternating key scan routine to continuously monitor the microcontroller's ability to detect a key shorted to any voltage. The microcontroller also monitors for keys that are closed longer than `BUTTON_STUCK_PER`, indicating a stuck key. If an error is detected, the associated key's data value will be set to its error code. If `DIAG_REPORTING_CFG` is set to enable the feature, the module will transmit the corresponding Diagnostic Trouble Code (DM1).

3.2. LED Indicator Diagnostics

LED diagnostics are performed at initial power up, wake-up and when the indicator is commanded on steady by the corresponding PGN. The LED diagnostics are not performed when an LED is blinking. If `DIAG_REPORTING_CFG` is set to enable it, the module will transmit the corresponding Diagnostic Trouble Code (DM1). Detected LED errors will also be reported with an error code in the corresponding bitfields of the [Prop B \(Indicator Set 1 Status\)](#) message, if that message is enabled.

3.3. Joystick Controller and VDC Diagnostics

3.3.1. Joystick Controller

If communication repeatedly fails between the proportional joystick component and the microcontroller, the module will report error values for the joystick and encoder data. This applies to both the single sensor and dual sensor joystick versions.

For a dual Hall effect Joystick Controller, normal output features a primary and a nearly identical secondary set of X and Y positional values for the joystick. This provides sensor

data transparency to the host ECU and allows the ECU to determine what action is to be taken in the event that the readings from the two sensors begin to differ by an unacceptable margin due to external magnetic influences.

3.3.2. Digital Joystick and Encoder

The VDC uses analog readings of the digital joystick inputs to detect shorts to the component joystick and encoder power. If an error is detected, the associated directional joystick data value will be set to its error code. If the DIAG_REPORTING_CFG is set the VDC will transmit the corresponding Diagnostic Trouble Code (DM1). If the encoder skips a state, the VDC will transmit a DM1.

4. Joystick Controller and VDC Configuration

In order to configure the device, the PC tool must send out an Address Claim message using source address 0xFD (Reserved for OEM) with the Grayhill Manufacturer Code of 294 (0x126). When the device detects this address claim, it will allow for configuration of the parameters in *Appendix B Device Configuration Parameters* and will be enabled until either a power cycle or another Address Claim message using source address 0xFD with a Manufacturer Code value other than 294 (0x126).

Configuration messages use the Proprietary A PGN and will respond to the message using PDU Specific (PS) values of the device's source address or the global address of 0xFF. The first byte contains the parameter ID. The message length is variable ranging from 1 to 64 where the upper limit is the longest allowed string value for some parameters.

Unless stated otherwise, new values will not take effect until a device reset occurs.

4.1. Reading

Parameters are read by only sending the Parameter ID with a message size of one where the actual CAN message's DLC is one. The parameter payload is returned using the Proprietary A PGN, where the first byte is the parameter ID and the value immediately follows.

4.1.1. Example

Reading the Button PGN having the parameter ID of 0x11, with the device having a source address of 0x80, send the following:

0x18EEFFFD 00 00 C0 24 00 00 00 00 -> Tool AC using MFG code of 294

0x18EF80FD 11 -> PropA PGN with a DLC of 1 and the data byte of 0x11

The unit responds with:

0x1CEFFD80 11 03 FF 00 00 -> PropA, DLC=3, Param value = 0x0000FF03

4.2. Writing

Parameters are written by sending the parameter ID followed by the payload. The message length is the payload size plus 1 for the parameter ID. Confirm programming by immediately performing a read operation of the parameter ID.

4.2.1. Example

Setting the Button PGN to 0xFF09 with the tool sending to a unit with source address 0x80.



0x18EEFFFD 00 00 C0 24 00 00 00 00 -> Tool AC using MFG code of 294 (puts device in config mode)
0x18EF80FD 11 09 FF 00 00 -> PropA PGN with a DLC of 5 (uses Button PGN param ID 0x11 to set it)

4.3. Parameter List

4.3.1. ECUID Part Number ID=0x00, Size <= 64

ECUID_PN: ASCII string up to 64 characters long occupying field 1 of the ECUID PGN request

4.3.2. ECUID Location ID=0x01, Size <= 64

ECUID_LOC: ASCII string up to 64 characters long occupying field 3 of the ECUID PGN request

4.3.3. ECUID Type ID=0x02, Size <= 64

ECUID_TYPE: ASCII string up to 64 characters long occupying field 4 of the ECUID PGN request

4.3.4. ECUID Manufacturer ID=0x03, Size <= 64

ECUID_MFG: ASCII string up to 64 characters long occupying field 4 of the ECUID PGN request

4.3.5. Component ID Make ID=0x04, Size <= 5

CI_MAKE: ASCII string up to 5 characters long occupying field 1 of the CI PGN request

4.3.6. Component ID Model ID=0x05, Size <= 64

CI_MODEL: ASCII string up to 64 characters long occupying field 2 of the CI PGN request

4.3.7. Component ID Serial Number ID=0x06, Size <= 64

CI_SN: ASCII string up to 64 characters long occupying field 3 of the CI PGN request

4.3.8. Component ID Unit Number ID=0x07, Size <= 64

CI_UN: ASCII string up to 64 characters long occupying field 4 of the CI PGN request

4.3.9. J1939 Name Identification ID=0x08, Size = 4

NAME_ID: Integer value representing the ID portion of the J1939 Name

4.3.10. J1939 Name Manufacturer Code ID=0x09, Size = 2

NAME_MFG_CODE: Integer value representing the Manufacturer Code portion of the J1939 Name

4.3.11. J1939 Name ECU Instance ID=0x0A, Size = 1

NAME_ECU_INST: Integer value representing the ECU Instance portion of the J1939 Name

4.3.12.J1939 Name Function Instance **ID=0x0B, Size = 1**

NAME_FUNC_INST: Integer value representing the Function Instance portion of the J1939 Name

4.3.13.J1939 Name Function **ID=0x0C, Size = 1**

NAME_FUNCTION: Integer value representing the Function portion of the J1939 Name

4.3.14.J1939 Name Vehicle System **ID=0x0D, Size = 1**

NAME_VEH_SYS: Integer value representing the Vehicle System portion of the J1939 Name

4.3.15.J1939 Name Vehicle System Instance **ID=0x0E, Size = 1**

NAME_VEH_SYS_INST: Integer value representing the Vehicle System Instance portion of the J1939 Name

4.3.16.J1939 Name Industry Group **ID=0x0F, Size = 1**

NAME_IND_GRP: Integer value representing the Industry Group portion of the J1939 Name

4.3.17.J1939 Name Arbitrary Address Capable **ID=0x10, Size = 1**

NAME_AAC: Integer value representing the Arbitrary Address Capable portion of the J1939 Name

4.3.18.Button PGN **ID=0x11, Size = 4**

BUTTON_PGN: The lower 16 bits is the PGN used for transmitting eight data bytes containing button status. The two bit field occupying locations 17 and 18 determines the data page where 0b00 is Data Page 0.

Used for the following messages depending on joystick/encoder used::

| | | |
|--|-----------------|-----------|
| 5.5.22.1 Prop B (Digital Joystick/Encoder Default PGN) | 65283 | (0xFF03), |
| 5.5.23.1 Basic Joystick Message 1 (BJM1) | 64982 (0xFDD6), | |

4.3.19.Button Priority **ID=0x12, Size = 1**

BUTTON_PRI: The lowest three bits set the priority of the PGN. All other bits are ignored.

4.3.20.Button Send On Event **ID=0x13, Size = 1**

BUTTON_SOE: A non-zero value causes the button PGN to transmit immediately on a button state change.

4.3.21.Button Transmit Period **ID=0x14, Size = 1**

BUTTON_TX_PER: The value sets the transmission period of the button PGN in units of 10ms. Example: A value of 20 sets the period to 200ms. A value of zero inhibits periodic transmission.

4.3.22.Indicator Status 1 PGN

ID=0x15, Size = 4

LED_STAT_1_PGN: The lower 16 bits is the PGN used for transmitting eight data bytes containing the indicator status of indicators 1 through 32. The two bit field occupying locations 17 and 18 determine the data page where 0b00 is Data Page 0. Be advised that if 0xA7## is chosen for this parameter, it will control the indicators of other Gen 2.0 modules on the CAN bus if ## matches one of their source addresses or is the global FFh.

4.3.23.Indicator Status 2 PGN

ID=0x16, Size = 4

**** UNUSED (3K Feature) **** DO NOT MODIFY ****

LED_STAT_2_PGN: The lower 16 bits is the PGN used for transmitting eight data bytes containing the indicator status of indicators 33 to 64. The two bit field occupying locations 17 and 18 determine the data page where 0b00 is Data Page 0.

4.3.24.Indicator Status PRI

ID=0x17, Size = 1

LED_STAT_PRI: The lowest three bits set the priority of the PGN. All other bits are ignored.

4.3.25.Indicator Status Send On Event

ID=0x18, Size = 1

LED_STAT_SOE: A non-zero value causes the indicator PGNs to transmit immediately on an indicator state change.

4.3.26.Indicator Status Transmit Period

ID=0x19, Size = 1

LED_STAT_TX_PER: The value sets the transmission period of the indicator PGNs in units of 10ms. Example: A value of 20 sets the period to 200ms. A value of zero inhibits periodic transmission. If BUTTON_TX_PER is 1 (10ms), then LED_STAT_TX_PER must be greater than 1 (10ms).

4.3.27.Diagnostic Blink Period

ID=0x1A, Size = 1

LED_DIAG_BLINK_PER: The value in units of 100ms determines the length of time after power-up that all of the indicators and backlights illuminate at full brightness. Example: A value of 30 will illuminate the lights for 3 seconds. A value of zero inhibits the diagnostic blink at power up.

4.3.28.LED COMM Timeout Period

ID=0x1B, Size = 1

LED_TIMEOUT_PER: The value in units of 100ms determines the length of time that needs to pass with the absence of any CAN traffic responsible for controlling the LEDs before a timeout. A value of zero disables this feature. The maximum timeout period is 25.5 seconds. The Indicators and Backlights will flash at a 2Hz rate to indicate loss of LED communication when the timer has expired. Upon timeout, if the device is configured to use low power mode the device will also cease all CAN message output until communication is restored, a button/encoder/joystick is actuated, or the Low Power Delay Period elapses and the device enters low power mode.

See also: 4.3.45 Low Power Delay Period

ID=0x2C, Size = 1.

4.3.29.LED Stuffing Configuration 1

ID=0x1C, Size = 3

**** GRAYHILL INTERNAL USE ONLY **** DO NOT MODIFY ****



Each bit within the three bytes represents an indicator LED controlled by the first driver and determines if that LED is stuffed or not. This is needed to prevent false failures during LED diagnostics.

4.3.30.LED Stuffing Configuration 2 **ID=0x1D, Size = 3**

**** GRAYHILL INTERNAL USE ONLY **** DO NOT MODIFY ****

Each bit within the three bytes represents an indicator LED controlled by the second driver and determines if that LED is stuffed or not. This is needed to prevent false failures during LED diagnostics.

4.3.31.Default Indicator Intensity **ID=0x1E, Size = 1**

LED_IND_DEFAULT: This parameter determines the indicator intensity before the device is commanded to change it. The default value is maximum brightness.

4.3.32.Default Backlight Intensity **ID=0x1F, Size = 1**

LED_BKLT_DEFAULT: This parameter determines the backlight intensity before the device is commanded to change it. The default value is maximum brightness.

4.3.33.Stuck Button Error Timeout Period **ID=0x20, Size = 1**

BUTTON_STUCK_PER: The value indicates the number of seconds a button needs to register an active press until it throws an error code for the corresponding button.

4.3.34.LED PWM BASE 1 **ID=0x21, Size = 24**

**** GRAYHILL INTERNAL USE ONLY **** DO NOT MODIFY ****

Each byte corresponds to an indicator LED and is used for balancing the intensity of the indicators when different LED types with different forward voltage drops are used. The valid range is between 0 and 255.

4.3.35.LED IREF BASE 1 **ID=0x22, Size = 24**

**** GRAYHILL INTERNAL USE ONLY **** DO NOT MODIFY ****

Each byte corresponds to an indicator LED and is used to fine tune the reference current when different LED types with different forward voltage drops are used. 0 to 255 valid.

4.3.36.LED PWM BASE 2 **ID=0x23, Size = 24**

**** UNUSED (3K Feature) **** GRAYHILL INTERNAL USE ONLY
**** DO NOT MODIFY ****

Refer to LED PWM BASE 1, ID=0x21, Size = 24

4.3.37.LED IREF BASE 2 **ID=0x24, Size = 24**

**** UNUSED (3K Feature) **** GRAYHILL INTERNAL USE ONLY
**** DO NOT MODIFY ****

Refer to LED IREF BASE 1, ID=0x22, Size = 24

4.3.38.DEVICE CONFIG

ID=0x25, Size = 2

**** GRAYHILL INTERNAL USE ONLY **** DO NOT MODIFY ****

Byte 1 => Number of Buttons. Valid values are 6 and 7, depending on whether the joystick or encoder has a button.

4.3.39.FLEXIO CONFIG

ID=0x26, Size = 1

**** UNUSED (3K Feature) **** GRAYHILL INTERNAL USE ONLY

**** DO NOT MODIFY ****

FLEXIO_CFG: Each nibble within the byte value is used to configure the two FlexIO peripherals. Refer to AUXIO 4 PGN for FlexIO Control.

FlexIO 1 is configured with the lower nibble. Configuration is as follows:

- 0 => Sourcing driver disabled. Input with hardware pulldown only.
- 1 => Sourcing driver enabled (default)

FlexIO 2 is configured with the upper nibble. Configuration is as follows:

- 0 => Sourcing and sinking drivers disabled. Input only. (default)
- 1 => Sourcing enabled, sinking disabled.
- 2 => Sourcing disabled, sinking enabled.
- 3 => Push-Pull Enabled.

4.3.40.Demo Mode

ID=0x27, Size = 1

DEVICE_DEMO_MODE: A non-zero value causes the module to have the ability to enter demo mode. Demo mode is entered by powering up the keypad while simultaneously holding down BTN #1 and BTN #7. All of the LEDs will blink twice and demo mode is entered regardless of the LED_DIAG_BLINK_PER setting.

4.3.41. Baud Rate

ID=0x28, Size = 1

DEVICE_BAUD: The value sets the baud rate of the device according to the following table.

| Data Value | Baud Rate |
|-------------|-----------|
| 0 | 1000K |
| 1 | 800K |
| 2 | 500K |
| 3 (default) | 250K |
| 4 | 125K |
| 5 | 100K |
| 6 | 50K |
| 7 | 20K |
| 8 | 10K |

4.3.42.AUXIO1 Priority

ID=0x29, Size = 1

**** UNUSED (3K Feature) **** DO NOT MODIFY ****

AUXIO1_PRI: The lowest three bits set the priority of the PGN. All other bits are ignored.

4.3.43.AUXIO1 Send On Event **ID=0x2A, Size = 1**

**** UNUSED (3K Feature) **** DO NOT MODIFY ****

AUXIO1_SOE: A non-zero value causes the AUXIO PGN to transmit immediately on a FLEXIOx state change when configured as input.

4.3.44.AUXIO1 Tx Period **ID=0x2B, Size = 1**

**** UNUSED (3K Feature) **** DO NOT MODIFY ****

AUXIO1_TX_PER: The value sets the transmission period of the button PGN in units of 10ms. Ex. A value of 20 sets the period to 200ms. A value of zero inhibits periodic transmission.

4.3.45.Low Power Delay Period **ID=0x2C, Size = 1**

LOW_POWER_DELAY_PER: This value, in units of 100ms, determines how long to wait until finally entering sleep mode after all of the conditions to enter sleep mode are satisfied. If LED timeout is configured to be used, the sleep timeout period will begin after LED timeout, but will be restarted in the event of button, joystick, or encoder actuations. LOW_POWER_DELAY_PER must be greater than 1 when LOW_POWER_CFG is not disabled. The device will not output CAN messages during this period in order to avoid waking up any other devices that may be entering low power mode.

4.3.46.Low Power Wake Signal Period **ID=0x2D,**
Size = 1

**** UNUSED (3K Feature) **** DO NOT MODIFY ****

LOW_POWER_WAKE_SIG_PER: This value, in units of 100ms, determines how long to assert the Wake Output signal on FLEXIO1. A value of 255 asserts the FLEXIO1 Wake Output for as long as the device is awake. A value of zero disables the FLEXIO1 Wake Output.

4.3.47.Low Power Config **ID=0x2E, Size = 1**

LOW_POWER_CFG: A value of 0 disables low power mode so that the device always stays awake. A value of 4 will enable low power mode so that timing out on the LED_TIMEOUT_PER and LOW_POWER_DELAY_PER will put the module in low power mode.

4.3.48.Diag Reporting Config **ID=0x2F, Size = 1**

DIAG_REPORTING_CFG:

- **Bit 0:** This bit determines if DTC reporting is enabled or not. When enabled (bit 0 set) the device will monitor the possible trouble codes as defined in [Active Diagnostic Trouble Codes \(DM1\)](#). Active trouble codes will be reported over the bus on the DM1 message. Active trouble codes that become inactive will be reported on DM2 message. Disabled by default.
- **Bit 1:** This bit determines if the DM1 message is continuously transmitted every second when no active faults exist. When set, the DM1 message is transmitted

every second regardless if active faults exist or not. When cleared, a DM1 message is only sent every second when active faults exist. In the event that all faults are cleared, the DM1 message is sent only once indicating that no faults are active. This is only active if bit 0 is set. Disabled by default.

4.3.49.Source Address ID=0x30, Size = 1

DEVICE_SA: The preferred J1939 source address

4.3.50.Source Address Save ID=0x31, Size = 1

DEVICE_SA_SAVE: When the device is configured for Arbitrary Address Capable and it successfully claims a different address than when it started, this option determines if this new source address is attempted at the next power-up (enabled) or if it tries the default source address.

4.3.51.Brightness Control Configuration ID=0x32, Size = 1

LED_BRIGHTNESS_CTRL_CONFIG: One of three options is used for LED brightness control. Refer to the table below:

| | |
|-------------------------------|---|
| LED_BRIGHTNESS_CTRL_CONFIG =0 | Responds to Normal Mode Proprietary A Brightness Command only. Cab Illumination message ignored. |
| LED_BRIGHTNESS_CTRL_CONFIG =1 | Cab Illumination Message Byte 1 only is used for both the indicator brightness and the backlight brightness. Prop A message ignored. |
| LED_BRIGHTNESS_CTRL_CONFIG =2 | Cab Illumination Message Byte 2 is used for the backlight brightness and Byte 3 is used for Indicator Brightness. Prop A message ignored. |

4.3.52.Encoder Type ID=0x33, Size = 1

* Only the VDCs use this parameter; the Joystick Controllers ignore it.

ENC_TYPE: This parameter tells the VDC whether a digital joystick or encoder is present. A value of 0 is used for VDCs with a rotary encoder. Joystick routines will be skipped and the associated fields in the Proprietary B CAN message will have all bits set. A value of 1 is used for VDCs with a digital joystick; it will enable reading and reporting of the joystick data.

4.3.53.Encoder Counter Max ID=0x34, Size = 2

ENC_COUNTER_MAX: The maximum value of the encoder counter.

4.3.54.Encoder Counter Rollover ID=0x35, Size = 1

ENC_COUNTER_ROLLOVER: A value of 1 will cause the encoder counter to roll over from the maximum counter value to 0 during clockwise encoder rotation and from 0 to the maximum value during counter-clockwise rotation. A value of 0 for this parameter will cause the encoder counter to stop counting at the maximum counter value during clockwise encoder rotation and at 0 during counter-clockwise rotation, without rolling over.

4.3.55.Button PGN Secondary ID=0x36, Size = 3

* Only the Joystick Controllers with a dual output proportional joystick use this parameter. Other Joystick Controllers and all VDCs ignore it.

BUTTON_PGN_SECONDARY: The lower 16 bits is the PGN used for transmitting eight data bytes containing the dual sensor proportional joystick's secondary signal status. The two bit field occupying locations 17 and 18 determines the data page where 0b00 is Data Page 0.

Used in the following message that is only applicable for dual output proportional joystick:

5.5.23.2 Basic Joystick Message 2 (BJM2) 64984 (0xFDD8)

5. Communications

5.1. Message Header Description

The following figure illustrates the format of the CAN 2.0B message ID. A brief description of each field follows.

| S O F | | Identifier 11 Bits | | | | | | | | | | | S R I D E | | Identifier Extension 18 Bits | | | | | | | | | | | | | | R T R | | | | |
|-------------|---|-----------------------|----|----|-------------|----|---------------------------------|----|----|----|----|----|-----------------------|----|---------------------------------|----|---|----|----|----|----|----|----|----|----------------|----|----|----|-------------|----|-------------|----|--|
| S O F | | Priority | | | R D P | | PDU Format (PF) 6 Bits (MSB) | | | | | | S R I D E | | PF (cont.) | | PDU Specific (PS) (Destination Address, Group Extension or Proprietary) | | | | | | | | Source Address | | | | | | R T R | | |
| | | 3 | 2 | 1 | | | 8 | 7 | 6 | 5 | 4 | 3 | | | 2 | 1 | 8 | 7 | 6 | 5 | 4 | 3 | 2 | 1 | 8 | 7 | 6 | 5 | 4 | 3 | 2 | 1 | |
| 1 | 2 | 3 | 4 | 5 | 6 | 7 | 8 | 9 | 10 | 11 | 12 | 13 | 14 | 15 | 16 | 17 | 18 | 19 | 20 | 21 | 22 | 23 | 23 | 25 | 26 | 27 | 28 | 29 | 30 | 31 | 32 | 33 | |
| | | 28 | 27 | 26 | 25 | 24 | 23 | 22 | 21 | 20 | 19 | 18 | | | 17 | 16 | 15 | 14 | 13 | 12 | 11 | 10 | 9 | 8 | 7 | 6 | 5 | 4 | 3 | 2 | 1 | 0 | |

5.1.1. Priority

This 3-bit field is used to define the priority during arbitration. '000' is the highest priority and is usually associated with high-speed control messages. Low priority is used for non-critical configuration and information messages.

5.1.2. DP (Data Page)

This 2-bit field defines on which data page (0,1 or 2) the message is defined in the J1939 specification. Page 0 contains the messages that are presently defined, while Pages 1 and 2 are for future expansion according to J1939.

5.1.3. Protocol Data Unit (PDU) - PDU Format (PF)

This 8-bit field determines the format of the message and is one of the fields that determine the Parameter Group Number of the message (see 5.1.6). If the value is between 0 and 239, the message is a PDU 1 Format message. These messages are sent to specific addresses.

5.1.4. Protocol Data Unit (PDU) - PDU Specific (PS)

The PDU Specific (PS) field is the Destination Address (DA). If the value is between 240 and 255, the message is a PDU 2 Format message. These messages are not sent to a specific address, but are instead broadcast to the entire network. The PS then becomes the Group Extension (GE) field.

5.1.5. Source Address

This 8-bit field is the source address of the device that sent the message.

5.1.6. Parameter Group Number

J1939 defines allowable messages by their Parameter Group Number (PGN). The Parameter Group Number is a 3-byte value that uniquely defines the message purpose. A PGN has the following format: If the PDU Format value for a message is less than 240, then the last 8 bits of the PGN are set to '0'. The specification gives the decimal equivalent of the PGNs. To obtain the PF and PS values to use for a specific message, convert the decimal value from the specification to hexadecimal and use the last two bytes. These values can then be used to either send messages on the network or to request messages from other source addresses.

5.2. Bit-field Location and Byte Ordering

The byte and bit ordering and location within the data field are per the J1939 specification. The first data byte is sent first and is referenced as Byte 1. The LSB of the data bytes are on the right and are referenced as Bit 1.

The convention used to locate a parameter in the data field is the same as specified in SAE-J1939/71. The format used is "R.x" where R is the byte number and x is the starting bit number within the byte. The length is the number of bits starting at this point.

Example 1: Location 4.3 with a length of 3 bits would have the value of 1 as illustrated below.

Byte 4 = 0x67 = 0b011**001**11. The bold value is the three bit field holding a value of 0b001.

Example 2: Location 4.3 with a length of 3 bits would have the value of 6 as illustrated below.

Byte 4 = 0x7b = 0b011**110**11. The bold value is the three bit field holding a value of 0b110.

5.3. Joystick Controller and VDC Source Address

The source address of the Grayhill standard Joystick Controllers and VDCs is set by default to 241 (F1h). This may be modified either dynamically if Dynamic Addressing is turned on, with the Commanded Address message in accordance with J1939-81, or with the [Configuration Command](#) (requires a reset). The source address value is stored in non-volatile memory. The ability to change the source address will allow multiple modules to coexist in the same system.

5.4. Physical Layer

The default bit rate is 250kbps per J1939/11. J1939/14 defines 500k. ISO11898-2 defines CAN-FD.

The connector is a 4 pin Deutsch equivalent with the following pin out:

1. Power
2. Ground
3. CAN_H
4. CAN_L

5.5. Standard PGNs

5.5.1. AUXIO 2 (Indicator Set 1)

42752 (0xA700)

Direction – Transmit (LED Status) & Receive (LED Control)

Priority – 6 (configurable)

Data Length – 8

Transmission Rate – 100ms (configurable)

***Note that Button 6 functionality is skipped because it has no indicators.**

| Start | Length | Button | LED Pos | Values |
|-------|---------|--------|---------|---|
| 1.1 | 2 Bits | 1 | Left | 0b00-Indicator Off 0b01-Indicator On 0b10-Indicator Blink 0b11-No Change |
| 1.3 | 2 Bits | 1 | Center | Same |
| 1.5 | 2 Bits | 1 | Right | Same |
| 1.7 | 2 Bits | 2 | Left | Same |
| 2.1 | 2 Bits | 2 | Center | Same |
| 2.3 | 2 Bits | 2 | Right | Same |
| 2.5 | 2 Bits | 3 | Left | Same |
| 2.7 | 2 Bits | 3 | Center | Same |
| 3.1 | 2 Bits | 3 | Right | Same |
| 3.3 | 2 Bits | 4 | Left | Same |
| 3.5 | 2 Bits | 4 | Center | Same |
| 3.7 | 2 Bits | 4 | Right | Same |
| 4.1 | 2 Bits | 5 | Left | Same |
| 4.3 | 2 Bits | 5 | Center | Same |
| 4.5 | 2 Bits | 5 | Right | Same |
| 4.7 | 2 Bits | 6 | N/A | Unused (0b11 - No Change) |
| 5.1 | 2 Bits | 6 | N/A | Unused (0b11 - No Change) |
| 5.3 | 2 Bits | 6 | N/A | Unused (0b11 - No Change) |
| 5.5 | 2 Bits | 7 | Left | Same as other used indicators |
| 5.7 | 2 Bits | 7 | Center | Same |
| 6.1 | 2 Bits | 7 | Right | Same |
| 6.3 | 6 Bits | N/A | N/A | All bits set - Unused |
| 7-8 | 2 Bytes | N/A | N/A | All bits set - Unused |

5.5.2. Cab Illumination

53248 (0xD000)

Direction – Receive

Data Length – 8

Data bytes used or ignored depending on value of BRIGHTNESS_CTRL_CONFIG.

| Start | Length | Desc. | Values * |
|-------|---------|--|---|
| 1 | 1 Byte | Cab Display Illumination Percentage (if BRIGHTNESS_CTRL_CONFIG = 1; otherwise ignored) | Valid Range 0 ~ 250 Resolution: 0.4%/Bit |
| 2 | 1 Byte | Switch Backlight Illumination Percentage (if BRIGHTNESS_CTRL_CONFIG = 2; otherwise ignored) | Valid Range 0 ~ 250 Resolution: 0.4%/Bit |
| 3 | 1 Byte | Switch Indication Illumination Brightness Percentage (if BRIGHTNESS_CTRL_CONFIG = 2; otherwise ignored) | Valid Range 0 ~ 250 Resolution: 0.4%/Bit |
| 4 | 5 Bytes | Unused | N/A |

5.5.3. Memory Access Request (DM14)

55552 (0xD900)

Used for memory reading/writing during device re-flashing. Refer to SAE J1939/73 for more detail.

5.5.4. Memory Access Response (DM15)

55296 (0xD800)

Used for memory reading/writing during device re-flashing. Refer to SAE J1939/73 for more detail.

5.5.5. Binary Data Transfer (DM16)

55040 (0xD700)

Used for memory reading/writing during device re-flashing. Refer to SAE J1939/73 for more detail.

5.5.6. Boot Load Data (DM17)

54784 (0xD600)

Used for entering and exiting the bootloader for device re-flashing. Refer to SAE J1939/73 for more detail.

5.5.7. Acknowledgement Message

59392 (0xE800)

Direction - Transmit

Data Length – 8

Transmission Rate – Upon appropriate response

| Start | Length | Desc. | Values * |
|-------|---------|------------------------------------|---|
| 1.1 | 1 Byte | Control Byte | 0 = Positive Acknowledgement 1 = Negative Acknowledgement 2 = Access Denied 3 = Cannot Respond |
| 2.1 | 1 Byte | Group Function | Refer to SAE-J1939-21 |
| 3.1 | 3 Bytes | Reserved by SAE | |
| 6.1 | 3 Bytes | Parameter Group being Acknowledged | |

This message is sent in response to a PGN Request of an unsupported PGN with the Control Byte having a value of one.

5.5.8. PGN Request

59904 (0xEA00)

Direction - Receive

Data Length – 3

| Start | Length | Desc. | Values |
|-------|--------|-------------------------------------|---|
| 1.1 | 1 Byte | Byte 1 of PGN being requested (LSB) | 0 to 255 |
| 2.1 | 1 Byte | Byte 2 of PGN being requested | 0 to 255 |
| 3.1 | 2 bits | Data Page | 0b00 -> Data Page 1 0b01 -> Data Page 2 0b10 -> Data Page 3 0b11 -> Reserved |
| 3.3 | 6 bits | N/A | Bits cleared |

5.5.9. Transport Protocol Data Transfer

60160 (0xEB00)

Used for messages that require nine bytes or more. Refer to J1939/21

5.5.10. Transport Protocol Connection Mgmt

60416 (0xEC00)

Used for messages that require nine bytes or more. Refer to J1939/21

5.5.11.Address Claimed

60928 (0xEE00)

Direction – Transmit and receive

Data Length – 8

Priority - 6

Transmission Rate – Upon boot or whenever requested

| Start | Length | Desc. | Values |
|-------|---------|---------------------------|--|
| 1.1 | 21 Bits | Identity Number | 0 to 2 ²¹ -1 |
| 3.6 | 11 Bits | Manufacturers Code | 294 (Assigned to Grayhill by SAE) |
| 5.1 | 3 Bits | ECU Instance | 0 (Default) |
| 5.4 | 5 Bits | Function Instance | 0 (Default) |
| 6.1 | 8 Bits | Function | 135 (Keypad, Default) * |
| 7.1 | 1 Bit | Reserved | 0 (Defined by SAE) |
| 7.2 | 7 Bits | Vehicle System | 0 (Default) * |
| 8.1 | 4 Bits | Vehicle System Instance | 0 (Default) |
| 8.5 | 3 Bits | Industry Group | 0 = Global (Default) * 1 = On-Highway Equipment 2 = Agricultural and Forestry Equipment 3 = Construction Equipment 4 = Marine 5 = Industrial-Process Control-Stationary 6 & 7 = Reserved |
| 8.8 | 1 Bit | Arbitrary Address Capable | 0 = Not Capable 1 = Capable (Default) |

*Refer to J1939 base document for the Function value based on the Industry Group and Vehicle System combinations

5.5.12.Prop A (Normal Mode)

61184 (0xEF00)

Direction –Receive
Priority – 7
Data Length – Variable

When Byte 1 is less than or equal to the button count:

*Note that although Button 6 has no indicators, Button 7 indicators are still controlled with a value of 7 in Byte 1

| Start | Length | Desc. | Values |
|-------|---------|-----------------------------------|--|
| 1.1 | 1 Byte | Indicator Bank (Button number) | 1..15 (Corresponding to the key number) |
| 2.1 | 4 Bits | Left Indicator | 0b0000-Off 0b0001-On 0b0010 – Blink Slow (approx.. ½ Hertz) 0b0011 – Blink Med. (approx.. 1 Hertz) 0b0100 – Blink Fast (approx. 2 Hertz) 0b1111 – Not Available |
| 2.4 | 4 Bits | Center Indicator | Same |
| 3.1 | 4 Bits | Right Indicator | Same |
| 4 | 5 Bytes | Not Used | N/A |

When Byte 1 has the value of 0x80 (Brightness Command)

Command ignored unless parameter BRIGHTNESS_CTRL_CONFIG = 0.

| Start | Length | Desc. | Values |
|-------|---------|---|---|
| 1 | 1 Byte | LED Intensity Command | 0x80 |
| 2 | 1 Byte | Switch Indication Illumination Brightness Percentage | Valid Range 0 ~ 250 Resolution: 0.4%/Bit |
| 3 | 1 Byte | Switch Backlight Illumination Brightness Percentage | Valid Range 0 ~ 250 Resolution: 0.4%/Bit |
| 4 | 5 Bytes | Not Used | N/A |

When Byte 1 has the value of 0xE9 (Encoder Configuration Command)

| Byte 1 | Byte 2 | Byte 3 | Byte 4 | Byte 5 | Byte 6 | Byte 7 | Byte 8 |
|--------|--------|----------|--------|--------|--------|--------|--------|
| 0xE9 | PARAM | ROLL OVR | xx | DATA | | 0x55 | 0xAA |

PARAM –

- **SET VAL (Param = 0):** Manually sets the encoder value to the value in DATA. Must be in the range from 0 to TOP. If value is greater than TOP then the value of TOP is used. This data is not stored in non-volatile memory
- **TOP (Param = 1):** Sets TOP, which is the maximum value to which the encoder counter will increment, to the value in DATA. Values range from 1 to 65534 with the default = 255. This data is stored in non-volatile memory
- **INIT VAL (Param = 2):** Changes the initial value after boot to the value in DATA. This data is stored in non-volatile memory. It does not manually change the encoder's value to DATA.

- **ROLL OVR** – A non-zero value in this byte, with the exception of 0xFF, causes the encoder counter value to roll over to zero when incremented at TOP and to roll over to TOP when decremented at zero. Otherwise the count remains at zero or TOP instead of rolling over.
- **DATA** - Input data used in setting of the parameters.

5.5.13.Prop A (Configuration Mode*) 61184 (0xEF00)

***Device is placed in this mode by sending the Address Claimed message from a Source Address of 0xFD with Manufacturer Code of 294 (Grayhill).**

Direction – Transmit and Receive

Priority – 7

Data Length – Variable

| Start | Length | Desc. | Values |
|-------|-----------|--------------------|---------------------------------|
| 1.1 | 1 Byte | Parameter ID Byte | Parameter ID |
| 2.1 | 2~(DLC-1) | Configuration Data | Variable as described in Sec. 4 |

Example - Setting the Button PGN to 0xFF09 with the tool, sending to the global address:

0x18EEFFFD 00 00 C0 24 00 00 00 00 -> Tool AC using MFG code of 294 (puts device in config mode)

0x18EEFFFD 11 09 FF 00 00 -> PropA PGN with a DLC of 5 (uses Button PGN param ID 0x11 to set it)

5.5.14.ECU Identification Information 64965 (0xFDC5)

Direction - Transmit

Data Length – Variable

Transmission Rate – Upon Request

Multi Packet Transferred – Yes

| Start | Length | Desc. | Values * |
|-------|--------|-------------------|------------------|
| A | <=64 | ECU Part Number | Ex. "3JYY1001-1" |
| B | <=64 | ECU Serial Number | Ex. "123456" |
| C | <=64 | ECU Location | Ex. "CAB" |
| D | <=64 | ECU Type | "VDC" |

5.5.15.Active Diagnostic Trouble Codes (DM1) 65226 (0xFECA)

The Diagnostic Trouble Code PGN uses the format described in J1939-73 that broadcasts to no specific address the diagnostic status of the keys, LEDs, IO etc. See Appendix A Diagnostic Trouble Codes

PGN: 65226 (0xFECA)
Direction: Transmit
Data Page: 0
PDU Format: 254
PDU Specific: 202
Priority: 6
Data Length: Variable (see transport protocol defined in SAE J1939-21)
TX Rate: 1s or On Change or On Request

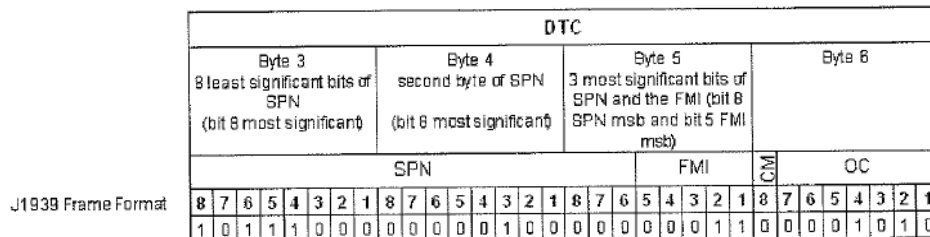

5.5.16. Previously Active Trouble Codes (DM2) 65226 (0xFECB)

Faults that go active then inactive can be read doing a PGN request for the DM2 message.

PGN: 65226 (0xFECB)
Direction: Transmit
Data Page: 0
PDU Format: 254
PDU Specific: 202
Priority: 6
Data Length: Variable (see transport protocol defined in SAE J1939-21)
TX Rate: On Request

5.5.17. Clear/Reset of Previously Active DTCs (DM3) 65227 (0xFECC)

Previously active trouble codes (DM2) are cleared by sending a PGN Request for the DM3 PGN.

PGN: 65227 (0xFECC)
Direction: Not Directly Transmitted or Received
Data Page: 0
PDU Format: 254
PDU Specific: 202
Priority: N/A
Data Length: N/A
TX Rate: A request clears the previously active trouble codes then a Positive Acknowledgement is sent

5.5.18. Clear/Reset of Active DTCs (DM11) 65235 (0xFED3)

Currently active trouble codes are cleared by sending a PGN Request for the DM11 PGN. When applicable and necessary, proportional joystick is reset, taking approximately 300ms to restore joystick data.

PGN: 65235 (0xFED3)
Direction: Not Directly Transmitted or Received
Data Page: 0
PDU Format: 254
PDU Specific: 202
Priority: N/A
Data Length: N/A
TX Rate: A request clears the active trouble codes then a Positive Acknowledgement is sent

5.5.19. Commanded Address

65240 (0xFED8)

Direction - Reception
Data Length – 9
Multi Packet Transferred – Yes

| Start | Length | Desc. | Values * |
|-------|---------|---------------------------------|-------------|
| 1 | 8 Bytes | J1939 Name of the target device | Variable |
| 9 | 1 Byte | New Source Address | 0x00 ~ 0xFC |
| | | | |

5.5.20. Software Identification

65242 (0xFEDA)

Direction - Transmit
Data Length – Variable
Transmission Rate – Upon Request
Multi Packet Transferred – Yes

| Start | Length | Desc. | Values |
|-------|----------|---------------------------|--|
| 1 | 1 Byte | Number of software fields | 1 to 125 |
| 2-N | Variable | Software ID field | ASCII characters. Each field delimited with an asterisk and up to 200 characters |

Each asterisk delimited field is further delimited by commas with the following sub fields

- Grayhill Software part number.
- Software revision
- Compile Date
- Compile Time.

When executing from the bootloader, only the bootloader's firmware information will be reported with the first byte containing a value of 1. When executing from the application, both the bootloader and application is reported with the first byte having a value of 2 and delimited with an asterisk.

5.5.21. Component ID

65259 (0xFEED)

Direction - Transmit
Data Length – Variable
Transmission Rate – Upon Request
Multi Packet Transferred – Yes

| Start | Length | Desc. | Values * |
|-------|--------|---------------|---------------------|
| A | <=5 | Make | Ex. "GHILL" |
| B | <=64 | Model | Ex. "Keypad 12 Btn" |
| C | <=64 | Serial Number | Ex. "1234" |
| D | <=64 | Unit Number | "ABCD" |

*All fields are ASCII characters and asterisk delimited

5.5.22. Digital Joystick and Rotary Encoder VDC Specific

Messages in this section only apply to VDCs with a digital joystick or rotary encoder.

5.5.22.1.Prop B (Digital Joystick/Encoder Default PGN) (0xFF03)

65283

Direction - Transmit

Priority – 6 (configurable)

Data Length - 8

Transmission Rate – 100ms (configurable)

| Start | Length | Desc. | Values |
|-------|---------|-------------------------|---|
| 1.1 | 2 bits | Joystick 1 X-Axis Right | 00 - Not pushed right 01 - Pushed right 10 - Error 11 - Unused |
| 1.3 | 2 bits | Joystick 1 X-Axis Left | 00 - Not pushed left 01 - Pushed left 10 - Error 11 - Unused |
| 1.5 | 2 bits | Joystick 1 Y-Axis Up | 00 - Not pushed up 01 - Pushed upward 10 - Error 11 - Unused |
| 1.7 | 2 bits | Joystick 1 Y-Axis Down | 00 - Not pushed down 01 - Pushed downward 10 - Error 11 - Unused |
| 2.0 | 2 bytes | Encoder data | Value between 0 and ENC_COUNTER_MAX, inclusive. 65,535 – Unused |
| 4.1 | 2 bits | Button 1 Status | 00 - Button not pressed 01 - Button pressed 10 - Error 11 - Unused |
| 4.3 | 2 bits | Button 2 Status | Same |
| 4.5 | 2 bits | Button 3 Status | Same |
| 4.7 | 2 bits | Button 4 Status | Same |
| 5.1 | 2 bits | Button 5 Status | Same |
| 5.3 | 2 bits | Button 6 Status | Same |
| 5.5 | 2 bits | Button 7 Status | Same |
| 5.7 | 2 bits | N/A | Unused |
| 6-8 | 3 bytes | N/A | Unused |

Example: Pressing button 2 will cause the following message to be transmitted.

ID=0x18FF03F1, LEN=8, DATA=0x00,0x00,0x00,0x04,0xC0,0xFF,0xFF,0xFF

Example: Pressing buttons 2 and 6 and pushing the joystick upward will cause the following message to be transmitted.

ID=0x18FF03F1, LEN=8, DATA=0x10,0x00,0x00,0x04,0xC1,0xFF,0xFF,0xFF

5.5.23. Joystick Controller Specific

Messages in this section only apply to Joystick Controllers with a proportional joystick. Basic Joystick Message 1 (BJM1) and BJM2 are defined in J1939-73. The Joystick Controller uses BJM 1 as its primary joystick data message. The dual Hall sensor version of the Joystick Controller uses BJM 2 to provide a secondary set of joystick readings from a different sensor in the same joystick device. Only BJM1 should be used for position values. For this device, the purpose of BJM2 is to provide a basis off of which to check that the readings from the primary sensor reported on BJM1 are reasonable.

5.5.23.1. Basic Joystick Message 1 (BJM1)

64982 (0xFDD6)

Direction - Transmit

Priority - 3

Data Length - 8

Transmission Rate – 100ms or on change, not to exceed 20ms

| Start | Length | Description | Value |
|-------|---------|--|---|
| 1.1 | 2 bits | Joystick 1 X Neutral Direction Status | 0b00 - Direction is not neutral 0b01 - Direction is neutral 0b10 - Error 0b11 - Unused |
| 1.3 | 2 bits | Joystick 1 X Negative Left Direction Status | 0b00 - Direction is not negative (not left) 0b01 - Direction is negative (left) 0b10 - Error 0b11 - Unused |
| 1.5 | 2 bits | Joystick 1 X Positive Right Direction Status | 0b00 - Direction is not positive (not rightward) 0b01 - Direction is positive (rightward) 0b10 - Error 0b11 - Unused |
| 1.7 | 10 bits | Joystick 1 X Position | 0x000 to 0x3E8 - Valid magnitude (0 to 1000). Value changes by 20 (2%) each step. 0x3FE - Error 0x3FF - Unused |
| 3.1 | 2 bits | Joystick 1 Y Neutral Direction Status | 0b00 - Direction is not neutral 0b01 - Direction is neutral 0b10 - Error 0b11 - Unused |
| 3.3 | 2 bits | Joystick 1 Y Negative Down Direction Status | 0b00 - Direction is not negative (not down) 0b01 - Direction is negative (down) 0b10 - Error 0b11 - Unused |
| 3.5 | 2 bits | Joystick 1 Y Positive Up Direction Status | 0b00 - Direction is not positive (not up) 0b01 - Direction is positive (up) 0b10 - Error 0b11 - Unused |
| 3.7 | 10 bits | Joystick 1 Y Position | 0x000 to 0x3E8 - Valid magnitude (0 to 1000). Value changes by 20 (2%) each step. 0x3FE - Error 0x3FF - Unused |
| 5.1 | 1 byte | Unused | All bits set |
| 6.1 | 2 bits | Button 4 Status | 00 - Button not pressed 01 - Button pressed 10 - Error 11 - Unused |
| 6.3 | 2 bits | Button 3 Status | Same |

| | | | |
|-----|--------|---|---|
| 6.5 | 2 bits | Button 2 Status | Same |
| 6.7 | 2 bits | Button 1 Status | Same |
| 7.1 | 2 bits | Encoder Clockwise Position Status | 00 - Not in CW position 01 - In CW position 10 - Error 11 - Unused |
| 7.3 | 2 bits | Button 7 Status | 00 - Button not pressed 01 - Button pressed 10 - Error 11 - Unused |
| 7.5 | 2 bits | Button 6 Status | Same |
| 7.7 | 2 bits | Button 5 Status | Same |
| 8.1 | 4 bits | Unused | All bits set |
| 8.5 | 2 bits | Encoder Neutral Position Status | 00 - Not in neutral position 01 - In neutral position 10 - Error 11 - Unused |
| 8.7 | 2 bits | Encoder Counter Clockwise Position Status | 00 - Not in CCW position 01 - In CCW position 10 - Error 11 - Unused |

5.5.23.2. Basic Joystick Message 2 (BJM2)

64984 (0xFDD8)

*Only used on the dual Hall sensor Joystick Controller version. Use this to double check BJM1, but only use BJM1 for actionable position data.

Direction - Transmit

Priority – 3

Data Length - 8

Transmission Rate – 100ms or on change, not to exceed 20ms

| Start | Length | Description | Value |
|-------|---------|--|---|
| 1.1 | 2 bits | Joystick 2 X Neutral Direction Status | 0b00 - Direction is not neutral 0b01 - Direction is neutral 0b10 - Error 0b11 - Unused |
| 1.3 | 2 bits | Joystick 2 X Negative Left Direction Status | 0b00 - Direction is not negative (not left) 0b01 - Direction is negative (left) 0b10 - Error 0b11 - Unused |
| 1.5 | 2 bits | Joystick 2 X Positive Right Direction Status | 0b00 - Direction is not positive (not rightward) 0b01 - Direction is positive (rightward) 0b10 - Error 0b11 - Unused |
| 1.7 | 10 bits | Joystick 2 X Position | 0x000 to 0x3E8 - Valid magnitude (0 to 1000). Value changes by 20 (2%) each step. 0x3FE - Error 0x3FF - Unused |
| 3.1 | 2 bits | Joystick 2 Y Neutral Direction Status | 0b00 - Direction is not neutral 0b01 - Direction is neutral 0b10 - Error 0b11 - Unused |
| 3.3 | 2 bits | Joystick 2 Y Negative Down Direction Status | 0b00 - Direction is not negative (not down) 0b01 - Direction is negative (down) 0b10 - Error 0b11 - Unused |
| 3.5 | 2 bits | Joystick 2 Y Positive Up Direction Status | 0b00 - Direction is not positive (not up) 0b01 - Direction is positive (up) 0b10 - Error 0b11 - Unused |
| 3.7 | 10 bits | Joystick 2 Y Position | 0x000 to 0x3E8 - Valid magnitude (0 to 1000). Value changes by 20 (2%) each step. 0x3FE - Error 0x3FF - Unused |
| 5-8 | 4 bytes | Unused | All bits set |

5.5.24.Prop B (Indicator Set 1 Status)

65447 (0xFFA7)

Direction – Transmit (LED Status)

Priority – 6 (configurable)

Data Length – 8

Transmission Rate – 100ms (configurable)

| Start | Length | Button | LED Pos | Values |
|-------|--------|--------|---------|---|
| 1.1 | 2 bits | 1 | Left | 0b00-Indicator Off or Unused 0b01-Indicator On 0b10-Indicator Error (Short or Open) |
| 1.3 | 2 bits | 1 | Center | Same |
| 1.5 | 2 bits | 1 | Right | Same |
| 1.7 | 2 bits | 2 | Left | Same |
| 2.1 | 2 bits | 2 | Center | Same |
| 2.3 | 2 bits | 2 | Right | Same |
| 2.5 | 2 bits | 3 | Left | Same |
| 2.7 | 2 bits | 3 | Center | Same |
| 3.1 | 2 bits | 3 | Right | Same |
| 3.3 | 2 bits | 4 | Left | Same |
| 3.5 | 2 bits | 4 | Center | Same |
| 3.7 | 2 bits | 4 | Right | Same |
| 4.1 | 2 bits | 5 | Left | Same |
| 4.3 | 2 bits | 5 | Center | Same |
| 4.5 | 2 bits | 5 | Right | Same |
| 4.7 | 2 bits | 6 | N/A | Unused |
| 5.1 | 2 bits | 6 | N/A | Unused |
| 5.3 | 2 bits | 6 | N/A | Unused |
| 5.5 | 2 bits | 7 | Left | Same as other used indicators |
| 5.7 | 2 bits | 7 | Center | Same |
| 6.1 | 2 bits | 7 | Right | Same |
| 6.3 | 2 bits | N/A | N/A | Unused |
| 6.5 | 2 bits | N/A | N/A | Unused |
| 6.7 | 2 bits | N/A | N/A | Unused |
| 7.1 | 2 bits | N/A | N/A | Unused |
| 7.3 | 2 bits | N/A | N/A | Unused |
| 7.5 | 2 bits | N/A | N/A | Unused |
| 7.7 | 2 bits | N/A | N/A | Unused |
| 8.1 | 2 bits | N/A | N/A | Unused |
| 8.3 | 2 bits | N/A | N/A | Unused |
| 8.5 | 4 bits | N/A | N/A | Unused |

6. APPENDIX

6.1. Appendix A Diagnostic Trouble Codes

| Failure Mode Description | SPN.FMI |
|--|---------------|
| EEPROM Corrupt | 520196.31 |
| Bus Idle Error | 520197.31 |
| Button XX Shorted | 5202XX.31 |
| Button XX Stuck | 5202XX.07 |
| LED X Error | (520220+X).31 |
| Reserved | 520281.31 |
| Proportional Joystick Com Lost | 520282.31 |
| Digital Joystick Shorted | 520283.31 |
| Digital Joystick Stuck | 520283.07 |
| Encoder State Skipped | 520284.31 |
| Proportional Dual XY Sensor Detected Ambient Magnetic Field | 520285.07 |

6.2. Appendix B Device Configuration Parameters

| Section | Field Name | Parameter ID | Valid Range | Default |
|---------|--------------------|--------------|---------------------|---|
| 4.3.1 | ECUID_PN | 0 (0x00) | | |
| 4.3.2 | ECUID_LOC | 1 (0x01) | | |
| 4.3.3 | ECUID_TYPE | 2 (0x02) | | |
| 4.3.4 | ECUID_MFG | 3 (0x03) | | |
| 4.3.5 | CI_MAKE | 4 (0x04) | | |
| 4.3.6 | CI_MODEL | 5 (0x05) | | |
| 4.3.7 | CI_SN | 6 (0x06) | | |
| 4.3.8 | CI_UN | 7 (0x07) | | |
| 4.3.9 | NAME_ID | 8 (0x08) | | |
| 4.3.10 | NAME_MFG_CODE | 9 (0x09) | 0-2047 | 294 (0x0126) |
| 4.3.11 | NAME_ECU_INST | 10 (0x0A) | 0-7 | 0 |
| 4.3.12 | NAME_FUNC_INST | 11 (0x0B) | 0-31 | 0 |
| 4.3.13 | NAME_FUNCTION | 12 (0x0C) | 0-255 | 135 (0x87) |
| 4.3.14 | NAME_VEH_SYS | 13 (0x0D) | 0-127 | 0 |
| 4.3.15 | NAME_VEH_SYS_INST | 14 (0x0E) | 0-15 | 0 |
| 4.3.16 | NAME_IND_GRP | 15 (0x0F) | 0-7 | 0 |
| 4.3.17 | NAME_AAC | 16 (0x10) | 0,1 | 0 (DISABLED) |
| 4.3.18 | BUTTON_PGN | 17 (0x11) | | 65283 (0xFF03) for VDC, 64982 (0xFDD6) for Joystick Controller |
| 4.3.19 | BUTTON_PRI | 18 (0x12) | 0-7 | 6 |
| 4.3.20 | BUTTON_SOE | 19 (0x13) | 0,1 | 1 (ENABLED) |
| 4.3.21 | BUTTON_TX_PER | 20 (0x14) | 0-255 | 10 (0x0A) 100ms |
| 4.3.22 | LED_STAT_1_PGN | 21 (0x15) | | 42752 (0xFFA7) |
| 4.3.23 | LED_STAT_2_PGN | 22 (0x16) | DO NOT MODIFY | Unused – N/A for this product |
| 4.3.24 | LED_STAT_PRI | 23 (0x17) | 0-7 | 6 |
| 4.3.25 | LED_STAT_SOE | 24 (0x18) | 0,1 | 0 (DISABLED) |
| 4.3.26 | LED_STAT_TX_PER | 25 (0x19) | 0-255 | 0 (0x00) DISABLED |
| 4.3.27 | LED_DIAG_BLINK_PER | 26 (0x1A) | 0-255 | 10 (0x0A) 1000ms |
| 4.3.28 | LED_TIMEOUT_PER | 27 (0x1B) | 0-255 Appendix C | 30 (0x1E) 3000ms |
| 4.3.29 | LED_STUFFING_1~24 | 28 (0x1C) | DO NOT MODIFY | Grayhill Use Only |
| 4.3.30 | LED_STUFFING_25~48 | 29 (0x1D) | DO NOT MODIFY | Grayhill Use Only Unused – N/A for this product |
| 4.3.31 | LED_IND_DEFAULT | 30 (0x1E) | 0-255 | 255 (0xFF) 100% |
| 4.3.32 | LED_BKLT_DEFAULT | 31 (0x1F) | 0-255 | 255 (0xFF) 100% |
| 4.3.33 | BUTTON_STUCK_PER | 32 (0x20) | 0-254 | 5 (0x05) 5 seconds |
| 4.3.34 | LED_PWM_BASE_1 | 33 (0x21) | DO NOT MODIFY | Grayhill Use Only |
| 4.3.35 | LED_IREF_BASE_1 | 34 (0x22) | DO NOT MODIFY | Grayhill Use Only |



An ISO-9001 Company

| | | | | |
|--------|------------------------|-----------|---------------------|--|
| 4.3.36 | LED_PWM_BASE_2 | 35 (0x23) | DO NOT MODIFY | Grayhill Use Only |
| 4.3.37 | LED_IREF_BASE_2 | 36 (0x24) | DO NOT MODIFY | Grayhill Use Only |
| 4.3.38 | DEVICE_CFG | 37 (0x25) | DO NOT MODIFY | Grayhill Use Only |
| 4.3.39 | FLEXIO_CFG | 38 (0x26) | DO NOT MODIFY | Unused – N/A for this product |
| 4.3.40 | DEVICE_DEMO_MODE | 39 (0x27) | 0-255 | 1 (ENABLED) |
| 4.3.41 | DEVICE_BAUD | 40 (0x28) | 0-8 | 3 (250K) |
| 4.3.42 | AUXIO1_PRI | 41 (0x29) | DO NOT MODIFY | Unused – N/A for this product |
| 4.3.43 | AUXIO1_SOE | 42 (0x2A) | DO NOT MODIFY | Unused – N/A for this product |
| 4.3.44 | AUXIO1_TX_PER | 43 (0x2B) | DO NOT MODIFY | Unused – N/A for this product |
| 4.3.45 | LOW_POWER_DELAY_PER | 44 (0x2C) | 1-255 Appendix C | 100 (0x64) 10000ms |
| 4.3.46 | LOW_POWER_WAKE_SIG_PER | 45 (0x2D) | DO NOT MODIFY | Unused – N/A for this product |
| 4.3.47 | LOW_POWER_CFG | 46 (0x2E) | 0,4 Appendix C | 4 (ENABLED) |
| 4.3.48 | DIAG_REPORTING_CFG | 47 (0x2F) | 0,1,3 | 0 (DISABLED NOT CONTINUOUS) |
| 4.3.49 | DEVICE_SA | 48 (0x30) | | 241 (0xF1) |
| 4.3.50 | DEVICE_SA_SAVE | 49 (0x31) | 0-255 | 0 (DISABLED) |
| 4.3.51 | BRIGHTNESS_CTRL_CONFIG | 50 (0x32) | 0,1,2 | 2 (USE CAB ILLUMINATION MESSAGE BYTES 2 & 3) |
| 4.3.52 | ENC_TYPE | 51 (0x33) | 0,1 | 0 (NO JOYSTICK – ENC. ONLY) |
| 4.3.53 | ENC_COUNTER_MAX | 52 (0x34) | 0-65534 | 255 (0x00FF) |
| 4.3.54 | ENC_COUNTER_ROLLOVER | 53 (0x35) | 0,1 | 1 (ROLLOVER ENABLED) |
| 4.3.55 | BUTTON_PGN_SECONDARY | 54 (0x36) | | 64984 (0xFDD8) for dual sensor Joystick Controller |
| 4.3.56 | ENC_COUNTER_START | 55 (0x37) | 0-65534 | 0 (0x0000) |

6.3. Appendix C Behavior from Timeout/Low Power Configuration

| Parameter | Val | Behavior - indicating CAN disruption and entering low power mode |
|---------------------|-----|--|
| LOW_POWER_CFG | 0 | Device will never enter low power mode. Device will not blink LEDs to indicate loss of CAN communication. |
| LED_TIMEOUT_PER | 0 | |
| LOW_POWER_DELAY_PER | > 0 | |
| LOW_POWER_CFG | 0 | Device will never enter low power mode. After time set by LED_TIMEOUT_PER has elapsed with no CAN communication, device will blink LEDs indefinitely to indicate this loss until communication is restored. |
| LED_TIMEOUT_PER | > 0 | |
| LOW_POWER_DELAY_PER | > 1 | |
| LOW_POWER_CFG | 4 | After time set by LED_TIMEOUT_PER has elapsed with no CAN communication, the device will directly enter low power mode without blinking LEDs to indicate loss of CAN communication. |
| LED_TIMEOUT_PER | > 0 | |
| LOW_POWER_DELAY_PER | 1 | |
| LOW_POWER_CFG | 4 | After time set by LED_TIMEOUT_PER has elapsed with no CAN communication, device will blink LEDs for time set by LOW_POWER_DELAY_PER to indicate this loss and then enter low power mode if communication has not been restored. Any button/joystick/encoder events during the blinking LED time frame will reset the LOW_POWER_DELAY_PER timer, further delaying the transition to low power mode. |
| LED_TIMEOUT_PER | > 0 | |
| LOW_POWER_DELAY_PER | > 1 | |

*Note that only the CAN messages for controlling LEDs are used to evaluate communication status in this context. If other messages are present on the CAN bus when the device enters low power mode from an absence of LED messages, the device will immediately re-enter run mode and the timeout cycle will repeat.

6.4. Appendix D FAQ and Examples

Resetting device without cycling power

Getting variable data written to flash to become active in the application may require either a power cycle or a reset command. To apply a reset command without cycling power, the following messages may be used:

| | |
|------------------------------------|--|
| 18EEFFFD 00 00 C0 24 00 00 00 00 | ADDRESS CLAIM |
| 18EF{SA}FD FE 01 00 00 00 00 00 00 | (SA: module source address) RESET |
| 1CD9FFFD 00 0D 00 60 00 08 07 00 | RUN MODE |

Changing an EEPROM configuration setting (example is changing low power mode)

1) First, send an address claim message with Grayhill's CAN manufacturer code and debug tool source address FD to make the unit listen to subsequent configuration messages:

```
1CEEFFFD 00 00 C0 24 00 00 00 00
```

2) Then send the message to set the parameter. The first data byte is the ID of the parameter being updated (see Appendix B) and the data bytes following it are the new value to be assigned. This example sets the LOW_POWER_CFG parameter (ID of 2E) to 0, where {SA} below is the source address of the unit being configured. A value of 0 for this parameter will prevent the unit from ever entering low power mode:

```
1CEF{SA}FD 2E 00
```

Note that the DLC for this message is 2 (only two data bytes, 2E 00, should be sent with the frame ID), but parameters with more data will require more data bytes.

*3) Reset the device by sending the following message, where {SA} is its source address:

```
18EF{SA}FD FE 01 00 00 00 00 00 00
```

*4) Put the device back into RUN mode for normal operation with the following message:

```
1CD9FFFD 00 0D 00 60 00 08 07 00
```

* The change will take effect at next power cycle should steps 3 & 4 be skipped.

Eliminating LED blink due to comm timeout

Use 1CEF{SA}FD 1B 00 for step #2 above.

Restoring factory defaults

Send 1CEEFFFD 00 00 C0 24 00 00 00 00

Send 18EF{SA}FD FD

Follow steps 3 and 4 above or power cycle device for changes to take effect