

KEY FEATURES

- Enclosed ITE Switching Power Supply
- Remote ON/OFF Function
- Standby 5V@1A
- High Efficiency up to 92%
- With P.F.C. Function >0.9
- Current Share Function
- Ultra Compact Size: 6.7 x 3.66 x 1.61 Inches
- 3-Year Product Warranty



ELECTRICAL SPECIFICATIONS

All specifications valid at normal input voltage, full load and +25°C after warm-up time unless otherwise stated.

Model No.	AQF700C-12S	AQF700C-15S	AQF700C-24S	AQF700C-28S	AQF700C-48S	
Max Output Wattage (W)	625W		700W			
Input	Voltage (Note 6)	90-264 VAC				
	Frequency (Hz)	47-63 Hz				
	Current (Full load)	<8 A max. (115 VAC) / <3.5 A max. (230 VAC)				
	Inrush Current (<2ms) (Cold Start)	< 55 A max. (115 VAC) / < 90 A max. (230 VAC)				
	Leakage Current	< 0.75 mA max. (264 VAC)				
	Power Factor (at 230 VAC)	PF>0.9 at Full Load				
Output	Voltage (V.DC.)	12V	15V	24V	28V	48V
	Voltage Accuracy	±2%				
	Voltage Adj. Range (V.DC)	±5% Output Voltage				
	Current (A) (max.)	52.08	41.66	29.16	25	14.58
	Line Regulation (115-264 VAC)	±0.5%				
	Load Regulation (10-100%) (typ.)	±1%				
	Maximum Capacitive Load	5,000µF	3,750µF	2,500µF	2,000µF	1,250µF
	Ripple & Noise (typ.)	160mV	160mV	240mV	280 mV	480mV
	Efficiency (at 230 VAC)	89%	90%	91%	92%	92%
	Hold-up Time (at 115 VAC)	5 ms min.				
Protection	Over Power Protection	Auto recovery				
	Over Voltage Protection	Auto recovery				
	Over Temperature Protection	Auto recovery				
	Short Circuit Protection	Auto recovery or Latch				
Isolation	Input-Output (V.AC)	4000VAC or 5656VDC				
	Input-PE (V.AC)	2000V				
	Output-PE (V.AC)	1500V				
Function	5V Stand by	5VSB: 5V@1A ; Tolerance ±10%				
	DC OK Signal (Power Good)	Turn ON: 3.7~5.7V ; Turn OFF: 0~1V				
	Remote Control	+RC / -RC: Power ON=open ; Power OFF=short				
	Current Share	CN4:CS, +V, -V are connected mutually in parallel.				

ELECTRICAL SPECIFICATIONS

All specifications valid at normal input voltage, full load and +25°C after warm-up time unless otherwise stated.

Model No.		AQF700C-12S	AQF700C-15S	AQF700C-24S	AQF700C-28S	AQF700C-48S
Environment	Operating Temperature	-30°C...+70°C (with derating)				
	Storage Temperature	-35°C...+85°C				
	Temperature Coefficient	±0.03%/°C (0~50°C)				
		±0.06%/°C (-30~0°C)				
	Altitude During Operation	5000m				
	Humidity	95% RH				
	Atmospheric Pressure	56 kPa to 106 kPa				
	MTBF	>100,000 h @ 25°C (MIL-HDBK-217F)				
	Vibration	IEC60068-2-6 (10~500Hz, 2G 10min./1cycle, 60min. each along X, Y, Z axes)				
Shock	IEC60068-2-27					
Physical	Dimensions (L x W x H)	6.7 x 3.66 x 1.61 Inches (170.0 x 93.0 x 41.0 mm) Tolerance ±0.5 mm				
	Weight	890 g				
Safety	Approval	UL / IEC / EN 62368-1				
EMC	Conducted and Radiated EMI	EN55032 (conducted class B, Radiated Class A)				
	EMS	EN55035 / EN60601-1-2 4th edition				

NOTE

- Ripple & Noise are measured at 20MHz of bandwidth by using a 6" twisted pair-wire terminated with a 0.1uF & 47uF parallel capacitor.
- Hold-up Time measured at 90% Vout.
- Strongly recommend to conduct this test with DC Voltage. If customer wishes to test with AC Voltage, please disconnect all Y-Capacitors from Arch power supply.
- Current Share:
 - The output voltage difference of each parallel single element should be less than 0.2 Vout.
 - Output power at parallel operation = rated power per unit x number of unit x 90%
 - Connect in parallel no more than 2 units. Please contact ARCH for advice if more than 2 is needed.
 - Minimum Load Should be 15%.

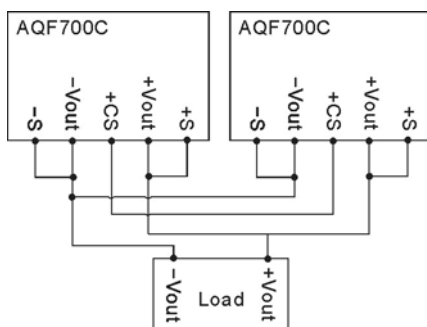

- CAUTION: Double pole, neutral fusing. Disconnect mains before servicing.
(ATTENTION : 2 poles avec fusible sur le neutre. Deconnecter le secteur avant intervention.)
- Please check the derating curve for more details.

DERATING

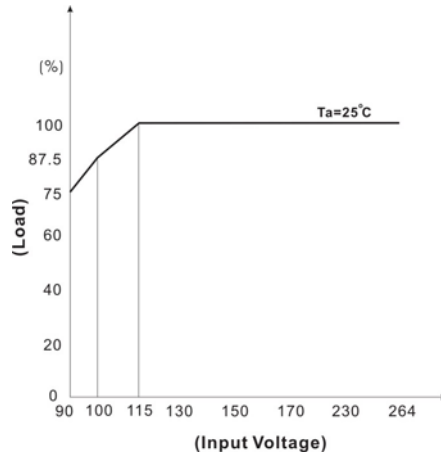
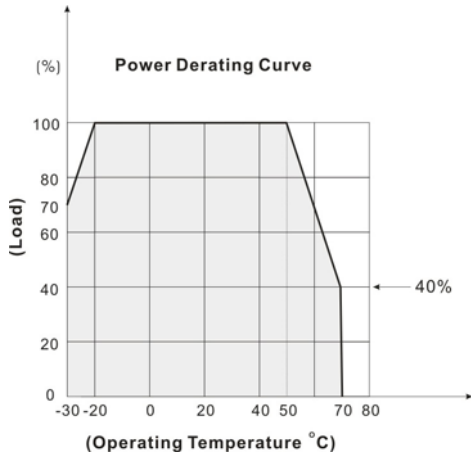

BLOCK DIAGRAM

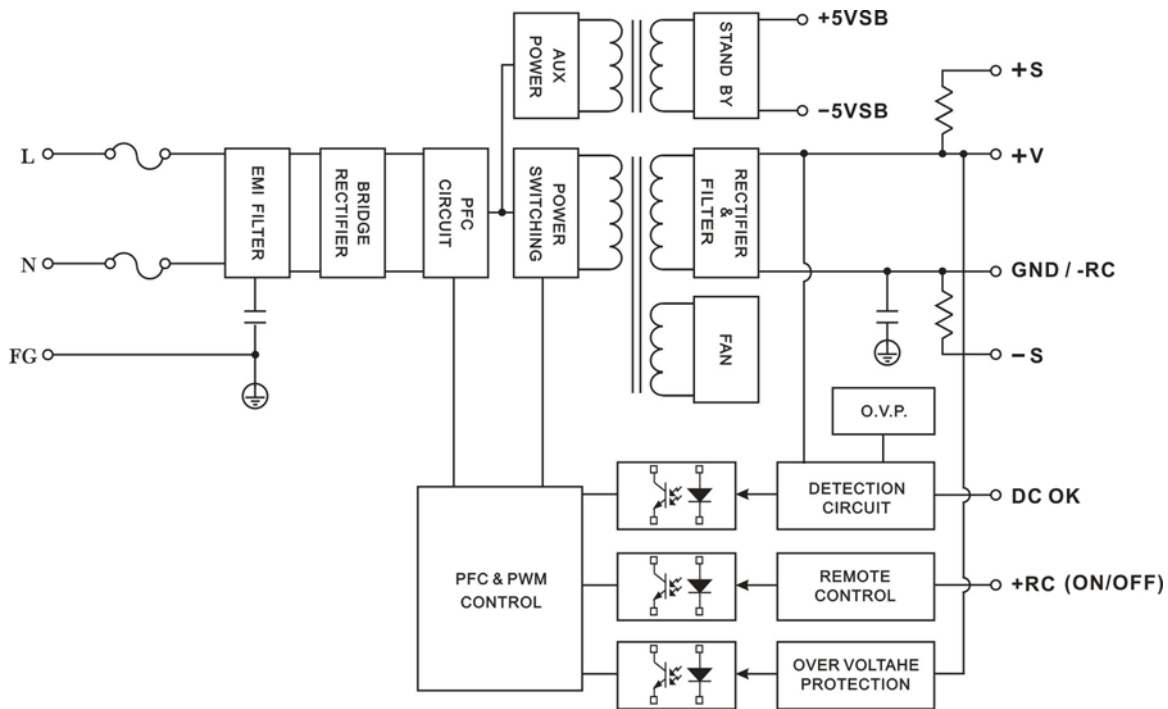

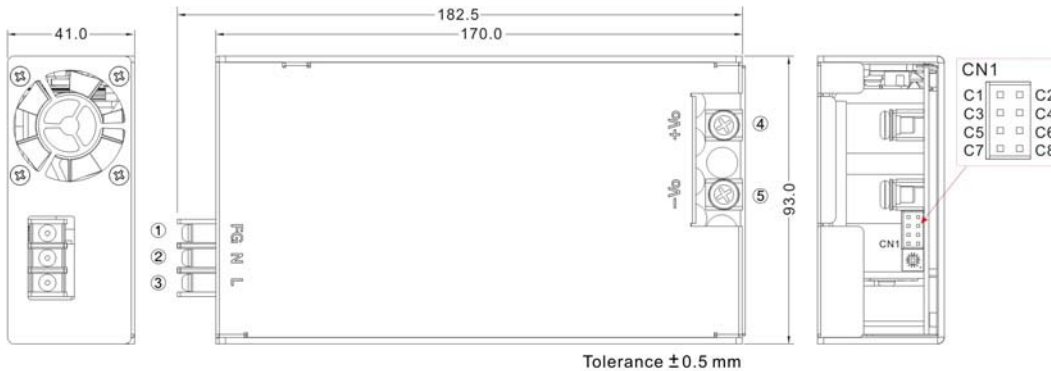
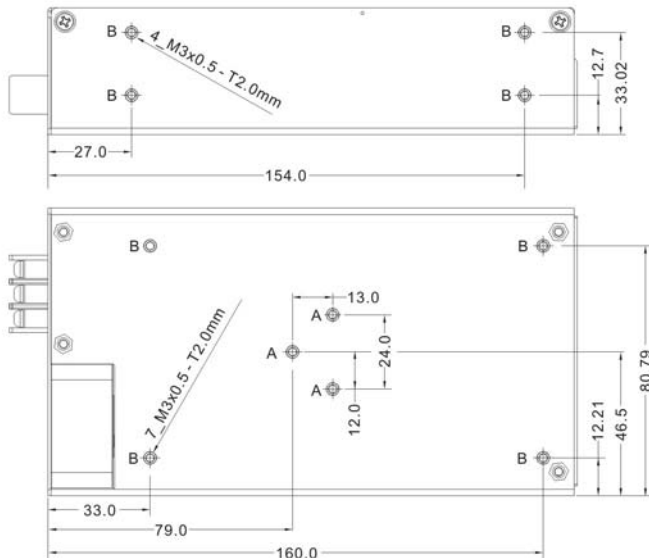
MECHANICAL DIMENSIONS (Top View)

 Tolerance ± 0.5 mm

A= For fixture to chassis only

A=M3x0.5P

B=For fixture to pcb/chassis only

B=M3x0.5P

 Torque:3 \pm 0.5 Kgf.cm

Input & output connectors tightening torque : 6 Kgf.cm

ASSEMBLY INSTRUCTIONS

*U Case T=2.0mm

Customer is advised to screw into the threads no more than 2.0mm

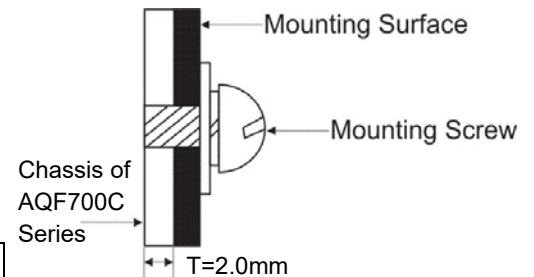

Brands					
PIN#	Single	Terminal			
A,B	PE	—	—	—	—
1	FG	ANYTEK YK-301-3P			
2	AC IN (N)				
3	AC IN (L)				
4	+DC OUT	M5 Pan HD screw in 2 positions Torque to 8 lbs-in(90 cNm) max.			
5	-DC OUT				

Connector Pin (CN1)					
Brands		Cheng Weei		JST	
PIN#	Single	Mating Housing	Terminal	Mating Housing	Terminal
C1	+S	PHD-H20-2X4P	PHD-T20	PHDR-08VS	SPHD-001T-P0.5
C2	-S				
C3	CS				
C4	-5V SB				
C5	GND / -RC				
C6	+RC				
C7	PG				
C8	+5V SB				

FUNCTION DESCRIPTION of CN1

Pin No.	Function	Description
C1	+S	Current Share Function Pin
C2	-S	
C3	CS	
C4	-5V SB	This pin connects to the negative terminal(-V). Return for DC-OK signal output.
C5	GND / -RC	This pin connects to the negative terminal(-V). Return for DC-OK signal output.
C6	+RC	Turns the output on and off by electrical or dry contact between pin C4 (-RC), Short: Power OFF, Open: Power ON.
C7	+PG	DC-OK Signal is a DC output. (DC-OK)
C8	+5V SB	Stand by voltage output ground 4.5~5.5V, referenced to pin C4 or C5(GND). The maximum load current is 1A.

AIR FLOW DIRECTION
