

## Description

The plug-in type ESX10 electronic circuit protector selectively disconnects DC 24 V load circuits by responding faster than the switch mode power supply to overload conditions. The manual ON/OFF switch on the device itself allows start-up of certain individual load circuits. As soon as the ESX10 detects overload or short circuit in its load circuit, it blocks the load output transistor and disconnects the current flow in the faulty circuit. After remedy of the failure, the load output of the ESX10 is re-activated by applying the operating voltage or manually by actuating the ON/OFF button.



## Features

- Approval to ATEX:
  - ⊕ II 3G Ex ec IIC T4 Gc (devices without relay)
  - ⊕ II 3G Ex ec nC IIC T4 Gc (devices with relay)
- Installation width: max 12.5 mm
- Fixed current rating 16 A
- Temperature range:
  - 40...+70 °C version ESX10-100 without signal output
  - 40...+60 °C version ESX10-105 with signal output to EN 60204-1, without condensation
- Pluggable design suitable for modular power distribution systems Module 17plus and Module 18plus

## Your benefits

- Wider range of applications due to Ex-zone approval ATEX zone 2 and current ratings up to 16 A
- Saves space in the control cabinet due to its slim design
- Enhances system availability by means of a clear failure detection and stable voltage supply
- Reduces downtimes through quick fault resolution
- Simplifies planning through clear sizes and ratings at active current limitation

## Approvals



## Compliances



**Technical data ( $T_{amb} = 25\text{ °C}$ ,  $U_B = \text{DC } 24\text{ V}$ )**

For further details please see: [www.e-t-a.de/ti\\_e](http://www.e-t-a.de/ti_e)

**Operating data**

Operating voltage $U_B$	DC 24 V $\pm$ 24 V (18...30 V)
Current rating $I_N$	fixed rating 16 A
Quiescent current $I_0$	in ON condition: typically 4 mA / without signal output in ON condition: typically 8 mA / with signal output
Visual status indication via	<ul style="list-style-type: none"> <li>● multicoloured LED:                             <ul style="list-style-type: none"> <li><b>green:</b> <ul style="list-style-type: none"> <li>- device is ON (S1 = ON)</li> <li>load circuit/Power-MOSFET connected</li> </ul> </li> <li><b>orange:</b> <ul style="list-style-type: none"> <li>- overload up to electronic disconnection</li> </ul> </li> <li><b>red:</b> <ul style="list-style-type: none"> <li>- after disconnection due to overload or short circuit</li> <li>- short circuit up to electronic disconnection</li> </ul> </li> </ul> </li> <li>- at undervoltage</li> <li><b>OFF:</b> <ul style="list-style-type: none"> <li>- manually switched off (S1 = OFF) or device is dead-voltage, status output</li> </ul> </li> <li>● SF potential-free signal output contact F (option)</li> <li>● ON/OFF position of the switch S1</li> </ul>

**Load circuit**

Load output	power MOSFET switching output (plus switching)
Overload and short circuit disconnection	typically 1.15 x $I_N$ with active current limitation
Trip times	see time/current characteristic typically 100 ms at overload or short circuit (see table 1)
Temperature disconnection	internal temperature monitoring with electronic disconnection
operating voltage with regard to low voltage	OFF at typically $U_B < 14\text{ V}$ ON at typically $U_B > 17\text{ V}$ with automatic ON and OFF switching
Switch-on delay $t_{start}$	typically 2 ms after each ON operation, after reset and after applying of $U_B$
Disconnection of load circuit	electronic disconnection without physical isolation
Leakage current in load circuit in OFF condition	typically 1 mA
Capacitive loads	up to 20,000 $\mu\text{F}$
Free-wheeling diode	external free-wheeling diode recommended for inductive load
Parallel connection of several load outputs	not allowed

**Technical data ( $T_{amb} = 25\text{ °C}$ ,  $U_B = \text{DC } 24\text{ V}$ )**

<b>Signal output F</b>	<b>ESX10-105</b>
Electrical data	potential-free signal output max. DC 30 V / 0.2 A min. 10 V / 1 mA
ESX10-105	single signal, make contact terminal design: 13 (SC) – 14 (SO) normal condition: closed fault condition: open
<b>Signal delay of signal output (F)</b>	in operating condition typically 20 ms in fault condition typically 220 ms
Error	signal output is in fault condition, if the device is OFF <ul style="list-style-type: none"> <li>- because of an overcurrent trip</li> <li>- because of lacking operating voltage <math>U_B</math></li> <li>- in the event of an undervoltage</li> <li>- because it was manually switched off</li> </ul>
<b>General data</b>	
Fail-safe-element	integral fail-safe element (fuse)  see table 1
Blade terminals	6.3 mm to EN 60934-A6.3-0.8
Housing material	moulded
Mounting	pluggable into power distribution systems for side-by-side mounting (module 17plus or 18plus by E-T-A)
Ambient temperature	to EN60204-1, without condensation -40 ... +70 °C, version ESX10-100 without signal output -40 ... +60°C version ESX10-105 with signal output
Storage temperature	-40...+70 °C
Humidity	96 hrs / 95% RH Humidity/40°C to IEC 60068-2-78, test Cab climate class 3K3 to EN60721
Vibration	3g test to IEC 60068-2-6, test Fc
Degree of protection	to EN60529, DIN 40050, enclosure IP30, terminals IP00
EMC requirements	noise emission: EN 61000-6-3 noise immunity: EN 61000-6-2
Insulation co-ordination (IEC 60934)	0.5 kV / pollution degree 2 reinforced insulation in operating area
Dielectric strength	max. DC 30 V (load circuit)
Insulation resistance (OFF condition)	n/a, only electronic disconnection
CE marking	to 2014/30/EU 2014/34/EU 2011/65/EU
Dimensions (w x h x d)	60 x 70.5 x 12.3 mm (tolerances to DIN ISO 286 part 1 IT13)
Mass	approx. 38 g

4

### Order numbering code

<b>Type No.</b>	
<b>ESX10</b>	Electronic Circuit Protector, with current limitation
<b>Version</b>	
<b>1</b>	without physical isolation
<b>Signal input</b>	
<b>0</b>	without
<b>Signal output</b>	
<b>0</b>	without
<b>5</b>	signal output make contact
<b>Operating voltage</b>	
<b>DC 24 V</b>	voltage rating
<b>Rated current</b>	
<b>16 A</b>	
<b>Approval</b>	
<b>E</b>	ATEX
<b>ESX10 - 1 0 5 DC 24 V - 16 A - E</b> ordering example	

Please be informed that we have minimum ordering quantities to be observed.

### Notes

- The user has to ensure that the cable cross section of the load circuit in question complies with the current rating of the ESX10 used.
- In addition special precautions must be taken in the system or machine (e.g. use of a safety PLC) which reliably prevent an automatic re-start of parts of the system (cf. Machinery Directive 2006/42/EC and EN 60204-1, Safety of Machinery). In the event of a failure (short circuit/overload) the load circuit will be disconnected electronically by the ESX10.

### Approvals

ESX10-10x-DC24V-16A-E				
Authority	Standard	File/certificate no.	Rated voltage	Current ratings
Bureau Veritas	ATEX 2014/34/EU EN 60079-0 EN 60079-7 EN 60079-15 ⊗ II 3G Ex ec IIC T4 Gc (without signal output) ⊗ II 3G Ex ec nC IIC T4 Gc (with signal output)	EPS 18 ATEX 1 127 X	24 DC V	16 A
Bureau Veritas IECEX	IEC 60079-0 IEC 60079-7 IEC 60079-15 Ex ec IIC T4 Gc (without signal output) Ex ec nC IIC T4 Gc (with signal output)	IECEX EPS 18.0059X	24 DC V	16 A
UL	UL 2367 UL508 / CSA C22.2 No. 14 UL 121201	File # E306740 File # E322549 File # E320024	24 DC V	16 A

**Table 1: Voltage drop, power loss, current limitation, trip times, fail-safe element, max. load current**

current rating $I_N$	typical voltage drop $U_{ON}$ at $I_N$	typical power loss $P_V$ at $I_N$ and DC24V	active current limitation typically	trip time $I_{KS}$	Fail-safe element	max. load current at 100 % ON duty single mounting				
						side-by-side mounting				
						$T_{amb} = 25^\circ C$	$T_{amb} = 40^\circ C$	$T_{amb} = 50^\circ C$	$T_{amb} = 60^\circ C$	$T_{amb} = 70^\circ C$
<b>ESX10-100-DC24V-16A-E without signal output</b>										
16 A	110 mV	1.9 W	$1.15 \times I_N$	100 ms	25 A	16 A	16 A	16 A	16 A	15 A
						15 A	14 A	13 A	12 A	9 A
<b>ESX10-105-DC24V-16A-E with signal output</b>										
16 A	110 mV	2.0 W	$1.15 \times I_N$	100 ms	25 A	16 A	16 A	16 A	16 A	-
						14 A	13 A	11 A	9 A	-

**Note:** When mounted side by side without convection cooling, performance may be thermally affected with continuous duty. Ambient temperature and load current can be different depending on approvals.

Schematic diagram ESX10-100/-105-DC24V-16A-E (example)

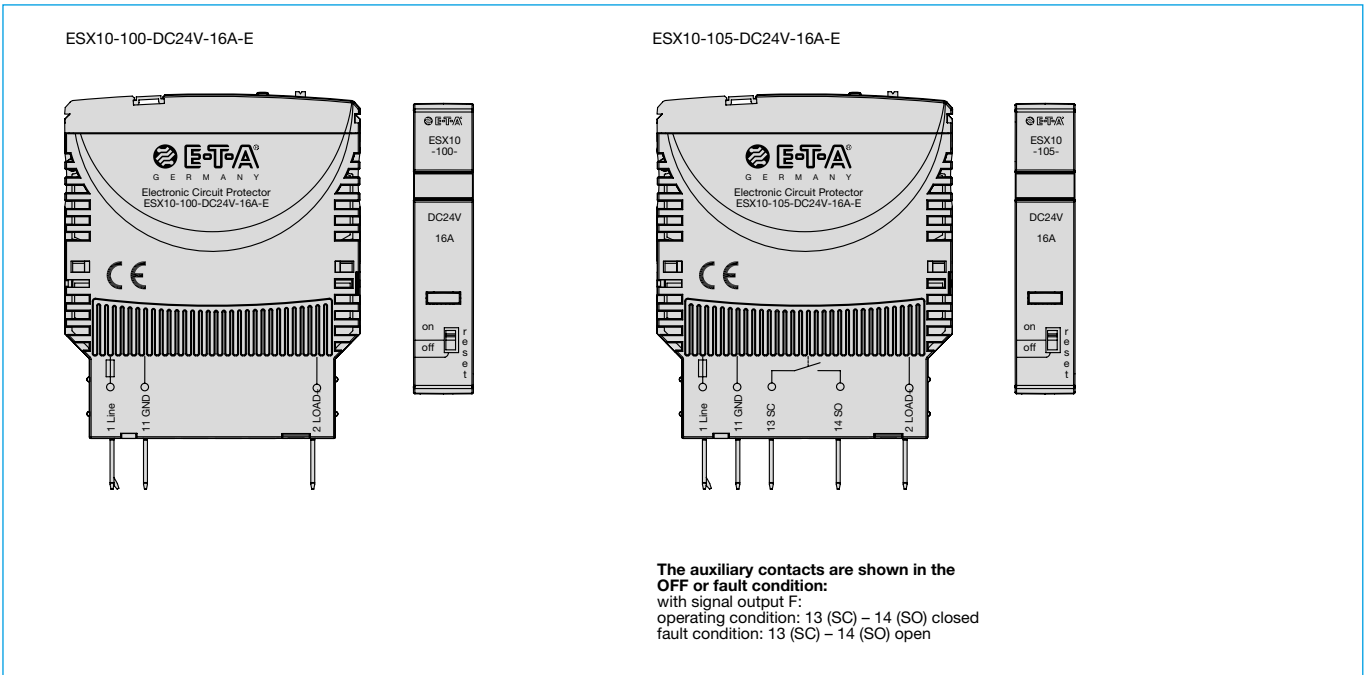

Dimensions ESX10-105-DC24V-16A-E

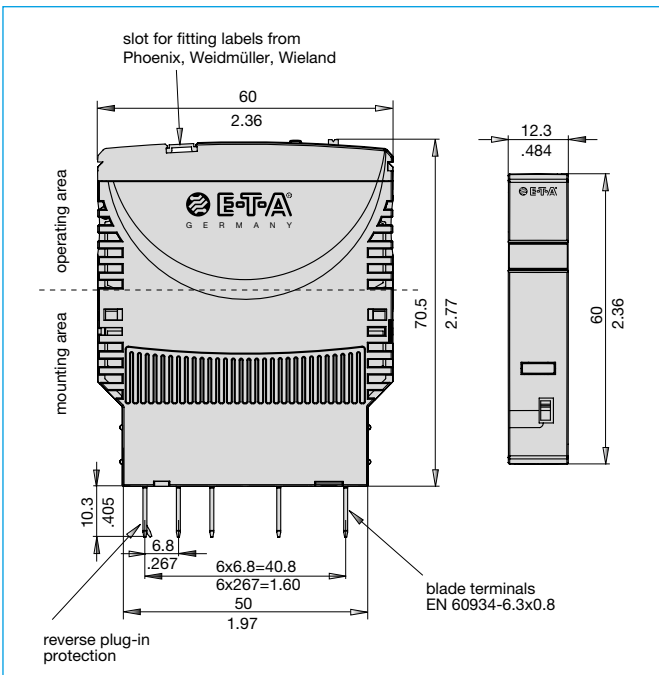

Technical data ( $T_{amb} = 25\text{ }^{\circ}\text{C}$ ,  $U_B = \text{DC} - 24\text{ V}$ )

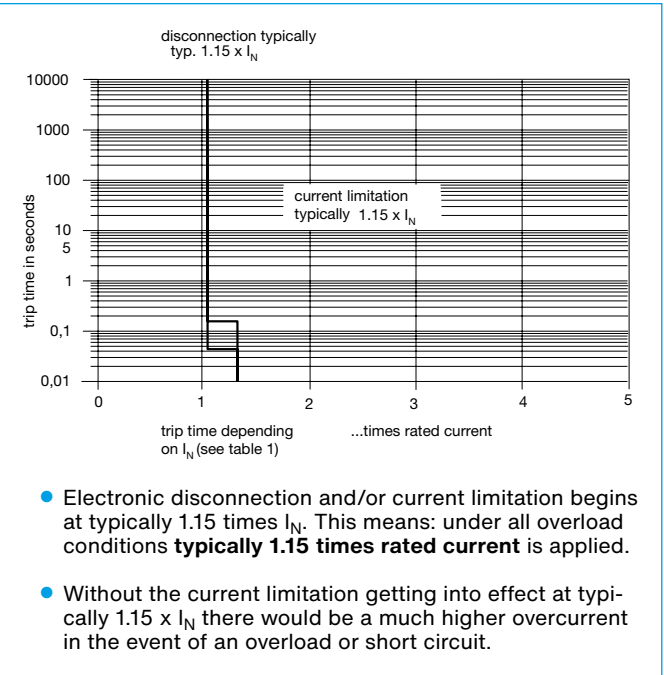

4

**Accessories**

**Module 17plus**

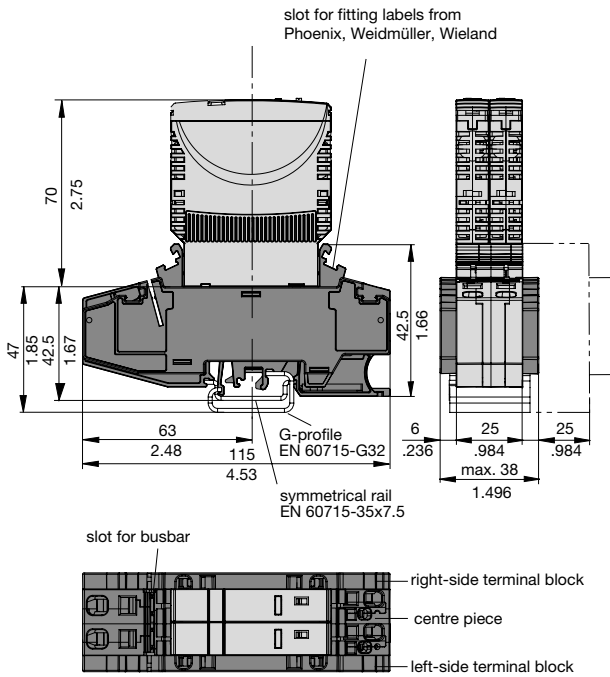

**Module 18plus**

