

FEATURES

- 3000 Vac Isolation
- Up to 182 Watts
- 4:1 Wide Input Range
- No Min. Load Required
- Remote ON/OFF
- Over Voltage and Over Current Protection
- Short Circuit and Over Load Protection

APPLICATIONS

- Railway Systems (EN50155, EN45545-2)
- Telecom
- Datacom
- Industrial Control
- Automation
- Measurement



GENERAL DESCRIPTION

The VTW150-Series is a family of 150 Watt single DC/DC converters designed for application where isolated output is required from a distributed power system. These converters achieve different housing versions without compromising performance or field reliability.

Models operate from an ultra wide 4:1 input bus voltage of 24, 48 and 110 Vdc offering output voltage levels of 3.3, 5, 12, 15, 24, 28 and 48 Vdc. Typical applications are in telecom/datacom, industry control and railway systems for on board power distribution.

SELECTION GUIDE

Model No.	nominal Input Voltage Range [Vdc]	nominal Output Voltage [Vdc]	Output Current @ full load [A]	Input Current @ No Load [mA]	Max. Capacitive Load [µF]	Efficiency typ. [%]
VTW150-243R3S	24 (9~36)	3.3	40	20	121000	88
VTW150-2405S		5	28	25	56000	90
VTW150-2412S	24 (8.5~36)	12	12	25	10000	90
VTW150-2415S		15	9.5	25	6300	91
VTW150-2424S		24	6	25	2500	90
VTW150-2428S		28	5	25	1700	90
VTW150-2448S		48	3	35	620	90
VTW150-483R3S		48 (16.5~75)	3.3	40	15	121000
VTW150-4805S	5		30	15	60000	91
VTW150-4812S	12		13	20	10800	91
VTW150-4815S	15		10	20	6600	91
VTW150-4824S	24		6.5	20	2700	91
VTW150-4828S	28		5.5	20	1900	91
VTW150-4848S	48		3.2	25	660	91
VTW150-1103R3S	110 (43~160)		3.3	43	10	130000
VTW150-11005S		5	32	10	64000	90
VTW150-11012S		12	15	10	12500	90
VTW150-11015S		15	12	10	8000	90
VTW150-11024S		24	7.5	10	3100	90
VTW150-11028S		28	6.5	10	2300	90
VTW150-11048S		48	3.8	10	790	90

Options DIL-Type

no Suffix: Negative logic; 0.20" pin length (Standard)
 Suffix L: Negative logic; 0.145" pin length
 Suffix P: Positive logic; 0.20" pin length
 Suffix A: Positive logic; 0.145" pin length
 Suffix -Y: SYNC-Pin (Standard is no Pin)
 Suffix -C: Case-Pin (Standard is no Pin)

Assembly Option:

no Suffix: None (Standard)
 Suffix -TH: Through hole type; no thread (no heat sink)
 Suffix -HS: Heat Sink; longitudinal fins; H=0.45"
 Suffix -HS1: Heat Sink; transverse fins; H=0.24"
 Suffix -HS2: Heat Sink; longitudinal fins; H=0.24"
 Suffix -HS3: Heat Sink; transverse fins; H=0.45"

Options Wall Mounted Type

The thermal block type is only for assembly of 0.20" pin length.

no Suffix: Negative logic; 0.20" pin length (Standard)
 Suffix P: Positive logic; 0.20" pin length

Assembly Option:

Suffix -T: Without EMC filter
 Suffix -TF: Integrated EMC filter, meets EN55032 Class A
 Suffix -TF1: Integrated EMC filter meets EN55032 Class A can be connected to PE

Examples: VTW150-2405S-YC-HS1 ... Standard DIL-Type, negative logic; 0.20" pin length; SYNC-pin & Case Pin Option, Heat Sink;
 VTW150-2405SP-TF Wall Mounted Type, positive logic; integrated EMC filter

INPUT SPECIFICATIONS

Item	Conditions		Min.	Typ.	Max.	Unit
Operating input voltage range	24 Vin (nom)	3.3 & 5Vout	9	24	36	Vdc
		others	8.5	24	36	
	48 Vin (nom)	16.5	48	75		
	110 Vin (nom)		43	110	160	
Start up voltage	24 Vin (nom)		-	-	9	Vdc
	48 Vin (nom)		-	-	18	
	110 Vin (nom)		-	-	43	
Shutdown voltage	24 Vin (nom)		7.3	7.7	8.1	Vdc
	48 Vin (nom)		15.5	16	16.3	
	110 Vin (nom)		33.0	34.5	36.0	
Start up time	Constant resistive load	Power up	-	75	-	ms
		Remote ON/OFF	-	75	-	
Input surge voltage	1s, max.	24 Vin (nom)	-	-	50	Vdc
		48 Vin (nom)	-	-	100	
		110 Vin (nom)	-	-	185	
Input Filter	-		Pi type			
Remote ON/OFF	Referred to -Vin pin	Negative logic (Standard)	DC-DC ON	Short or 0 ~ 1.2 Vdc		
			DC-DC OFF	Open or 3 ~ 12 Vdc		
		Positive logic (Option)	DC-DC ON	Open or 3 ~ 12 Vdc		
			DC-DC OFF	Short or 0 ~ 1.2 Vdc		
		Input current of Ctrl pin		-0.5	-	1
Remote off input current		-	3	-	mA	
Sync pin signal			-0.3		5.6	Vdc

OUTPUT SPECIFICATIONS						
Item	Conditions		Min.	Typ.	Max.	Unit
Voltage accuracy	-		-1.0	-	+1.0	%
Line regulation	Low Line to high line @ full load		-0.1	-	+0.1	%
Load regulation	No load to full load		-0.1	-	+0.1	%
Voltage adjustability	Max. output deviation is inclusive of remote sense		-20	-	+10	%
Remote sense	% of Vout (nom) if remote sense is not being used, Sense pins should be connected to corresponding polarity OUTPUT pins.		-	-	10	%
Ripple and noise (Measured by 20MHz bandwidth)	With a 1 μ F/25 V X7R MLCC and a 22 μ F/25V POS-CAP	3.3Vout, 5Vout		75		mVp-p
	With a 1 μ F/25 V X7R MLCC and a 22 μ F/25V POS-CAP	12Vout, 15Vout		100		
	With a 4.7 μ F/50 V X7R MLCC	24Vout, 28Vout		200		
	With a 2.2 μ F/100 V X7R MLCC	48Vout		300		
Temperature coefficient	-		-0.02	-	+0.02	%/°C
Transient response recovery time	25% load step change		-	200	250	μ s
Over voltage protection	% of Vout(nom); Hiccup mode		115	-	130	%
Over load protection	% of Iout rated, Hiccup mode		120	-	150	%
Short circuit protection	-		continuous, automatic recovery			

ENVIRONMENTAL SPECIFICATIONS						
Item	Conditions		Min.	Typ.	Max.	Unit
Operating ambient temperature	Base-plate		-40	-	+115	°C
Maximum case temperature	-		-	-	+115	°C
Over temperature protection	-		-	120	-	°C
Storage temperature range	Terminal block type		-40	-	+105	°C
	Others		-55	-	+125	
Thermal impedance	Module without assembly option		-	6.1	-	°C/W
	Only mount on the iron base-plate		-	2.8	-	
	Heat-sink type with 0.24" Height		-	5.1	-	
	Heat-sink type with 0.45" Height		-	4.6	-	
Thermal shock	-		MIL-STD-810F			
Shock	-		EN61373, MIL-STD-810F			
Vibration	-		EN61373, MIL-STD-810F			
Relative humidity	-		5% to 95% RH			

GENERAL SPECIFICATIONS

Item	Conditions	Min.	Typ.	Max.	Unit	
Isolation voltage	110Vin(nom): 1 minute, (Reinforced insulation)	Input to Output	3000	-	-	Vdc
		Input to case	1500	-	-	
	Others: 1 minute	Input to Output	3000	-	-	Vdc
		Input to case	1600	-	-	
Isolation resistance	500 Vdc	1			GΩ	
Isolation capacitance	-	-	-	2500	pF	
Switching frequency	-	225	250	275	kHz	
Safety standards	-	IEC / UL / EN60950-1 (designed to meet)				
Approval standards	-	EN50155, EN45545-2				
Case material	24vin(nom) and 48Vin(nom)	Metal				
	110Vin(nom)	Aluminum base-plate with plastic case				
Base material	24vin(nom) and 48Vin(nom)	FR4 PCB				
Potting material	-	Silicone (UL94 V-0)				
Weight	Module stand alone	105g (3.70oz)				
	„-T“ type	235g (8.29oz)				
	„-TF“ type	280g (9.88oz)				
	„-TF1“ type	287g (10.12oz)				
MTBF	MIL-HDBK-217F, Full load	3.500 x 10 ⁵ hrs				

CHARACTERISTIC CURVE

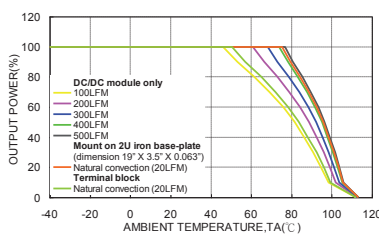

VTW150-4805S Derating Curve
(See Thermal Conditions)

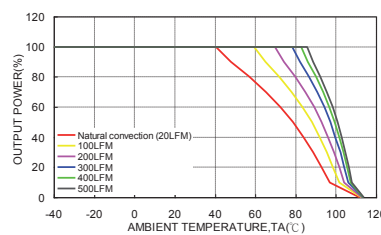

VTW150-4805S Derating Curve
with 0.24" Height Heat Sink
(See Thermal Conditions)

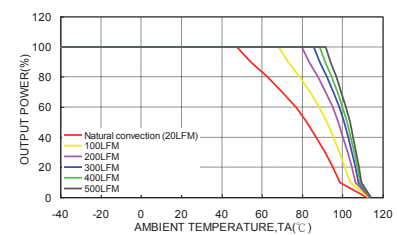

VTW150-4805S Derating Curve
with 0.45" Height Heat Sink
(See Thermal Conditions)

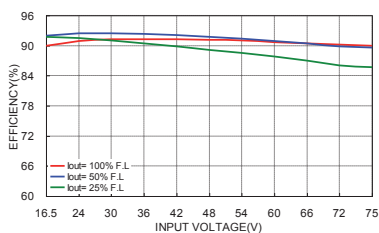

VTW150-4805S Efficiency vs. Input Voltage

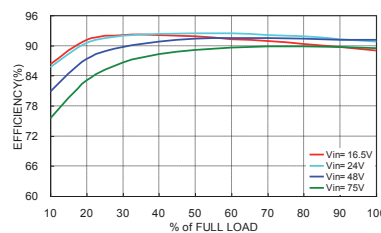

VTW150-4805S Efficiency vs. Output Voltage

EMC SPECIFICATIONS			
Item	Conditions		Level
EMI	EN55011, EN55032	„-TF“ type models	Class A
		„-TF1“ type models	Class A
		Other models; with external components	Class A, Class B
*Connecting four screw bolts to shield plane will help to reduce the EMI.			
ESD	EN61000-4-2	Air $\pm 8\text{kV}$ and Contact $\pm 6\text{kV}$	Perf. Criteria A
Radiated Immunity	EN61000-4-3	20 V/m	Perf. Criteria A
Fast transient	EN61000-4-4	$\pm 2\text{ kV}$	Perf. Criteria A
	24 Vin, 48 Vin	With 2 pcs of aluminum electrolytic capacitor (Nippon chemi-con KY series, 220 $\mu\text{F}/100\text{V}$)	
	110 Vin	With 2 pcs of aluminum electrolytic capacitor (Nippon chemi-con KXJ series, 150 $\mu\text{F}/200\text{V}$)	
Surge	EN61000-4-5	EN55024 $\pm 2\text{kV}$ and EN50155 $\pm 2\text{kV}$	Perf. Criteria A
	24 Vin, 48 Vin	With 2 pcs of aluminum electrolytic capacitor (Nippon chemi-con KY series, 220 $\mu\text{F}/100\text{V}$)	
	110 Vin	With 2 pcs of aluminum electrolytic capacitor (Nippon chemi-con KXJ series, 150 $\mu\text{F}/200\text{V}$)	
Conducted immunity	EN61000-4-6	10 Vrms	Perf. Criteria A
Power frequency magnetic field	EN61000-4-8	100A/m continuous; 1000A/m 1 second	Perf. Criteria A

Note:

Input source impedance: The power module will operate as specifications without external components, assuming that the source voltage has a very low impedance and reasonable input voltage regulation. Highly inductive source impedances can affect the stability of the power module.

Since real-world voltage source has finite impedance, performance can be improved by adding external filter capacitor. The 24Vin and the 48Vin model recommended Nippon Chemi-con KY series, 100 $\mu\text{F}/100\text{V}$ or better capacitor. The 110Vin model recommended Ruby-con BXF series, 68 $\mu\text{F}/200\text{V}$.

CAUTION: This power module is not internally fused. An input line fuse must always be used.

FUSE CONSIDERATION

This power modules is not internally fused. An input line fuse must always be used.

This encapsulated power module can be used in a wide variety of applications, ranging from simple stand-alone operation to an integrated part of sophisticated power architecture.

To maximum flexibility, internal fusing is not included; however, to achieve maximum safety and system protection, always use an input line fuse.

The input line fuse suggest as below:

Model	Fuse Rating [A]	Fuse Type
24 Vin-Models	25	Fast-Acting
48 Vin-Models	15	Fast-Acting
110 Vin-Models	8	Fast-Acting

The table based on the information provided in this data sheet on inrush energy and maximum DC input current at low Vin.

MECHANICAL DRAWING

24 Vin and 48 Vin Models

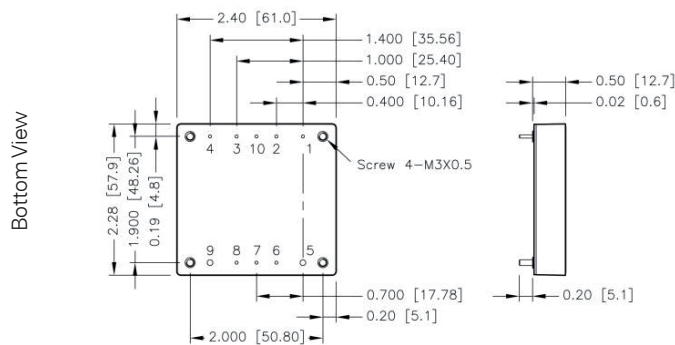

- The screw locked torque: MAX 5.0kgf-cm / 0.49N-m

110 Vin Models

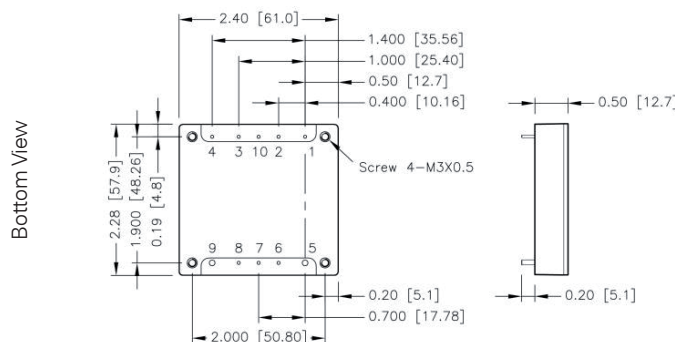

- The screw locked torque: MAX 3.5kgf-cm / 0.34N-m

PIN CONNECTION

PIN	Define	Diameter
1	-Vin	0.04 inch
2	Case (option)	0.04 inch
3	Ctrl	0.04 inch
4	+Vin	0.04 inch
5	-Vout	0.08 inch
6	-Sense	0.04 inch
7	Trim	0.04 inch
8	+Sense	0.04 inch
9	+Vout	0.08 inch
10	Sync (option)	0.04 inch

- All dimensions in inch [mm]
- Tolerance: x.xx±0.02 [x.x±0.5]
x.xx±0.01 [x.x±0.25]
- Pin dimension tolerance ±0.004 [±0.10]

MECHANICAL DRAWING - TERMINAL BLOCKTYPE OPTION

-T Option Models

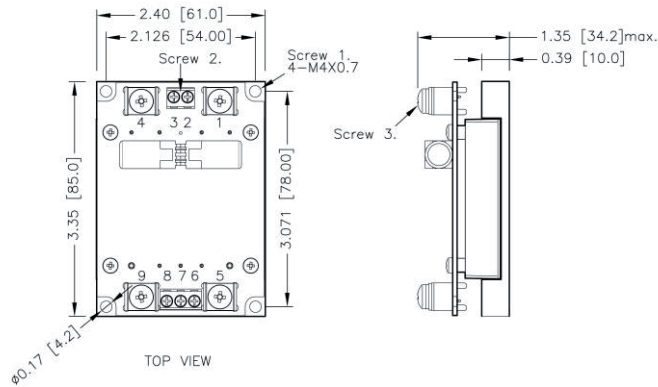

TERMINAL CONNECTION

PIN	Define
1	-Vin
2	NC
3	Ctrl
4	+Vin
5	-Vout
6	-Sense
7	Trim
8	+Sense
9	+Vout

-TF Option Models

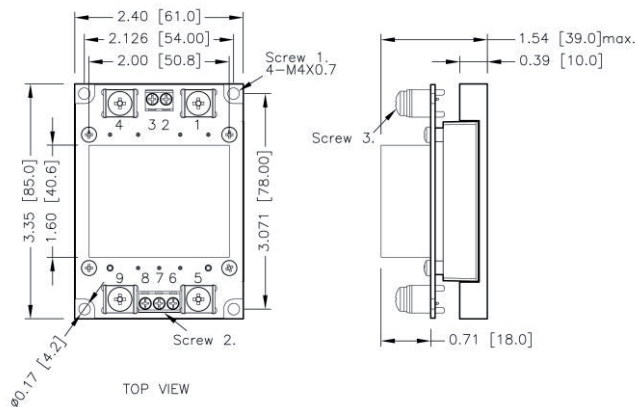

- All dimensions in inch [mm]
- Tolerance: $x.xx \pm 0.02$ [$x.x \pm 0.5$]
 $x.xx \pm 0.01$ [$x.x \pm 0.25$]
- Screw 1 locked torque:
MAX 11.2kgf-cm / 1.10N-m
- Screw 2 locked torque:
MAX 5.2kgf-cm / 0.51N-m
- Screw 3 locked torque:
MAX 16.8kgf-cm / 1.65N-m

-TF1 Option Models

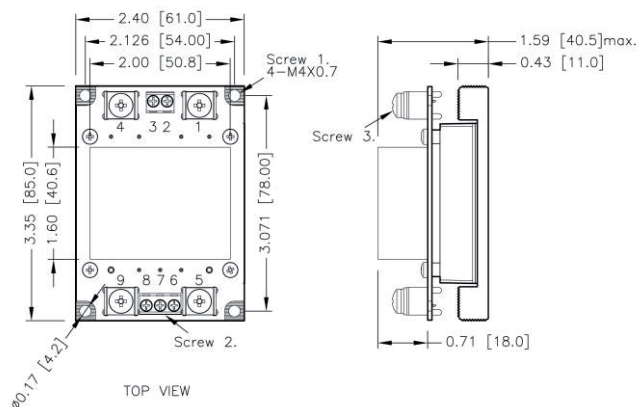

RECOMMENDED PAD LAYOUT

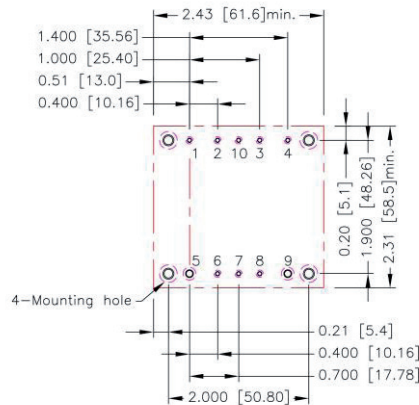

All dimensions in inch [mm]

Pad size (lead free recommended)

Through hole 1,2,3,4,6,7,8,10: diameter 0.051 [1.20]

Through hole 5,9: diameter 0.09[2.30]

Through hole of mounting: diameter 0.126 [3.20]

Top view pad 1,2,3,4,6,7,8,10: diameter 0.064 [1.63]

Top view pad 5,9: diameter 0.113 [2.88]

Top view pad of mounting: diameter 0.157 [4.00]

Bottom view pad 1,2,3,4,6,7,8,10: diameter 0.102 [2.60]

Bottom view pad 5,9: diameter 0.181 [4.60]

Bottom view pad of mounting: diameter 0.252 [6.40]

THERMAL CONSIDERATIONS

The power module operates in a variety of thermal environments. However, sufficient cooling should be provided to help ensure reliable operation of the unit. Heat is removed by conduction, convection, and radiation to the surrounding Environment. Proper cooling can be verified by measuring the point as the figure below.

The temperature at this location should not exceed „Maximum case temperature“

When Operating, adequate cooling must be provided to maintain the test point temperature at or below „Maximum case temperature“

You can limit this Temperature to a lower value for extremely high reliability.

Thermal test condition with vertical direction by natural convection (20LFM).

OUTPUT VOLTAGE ADJUSTMENT

Output voltage is adjustable for 10% trim up or -20% trim down of nominal output voltage by connecting an external resistor between the Trim pin and either the +Sense or -Sense pin.

With an external resistor between the Trim and -Sense, the output voltage set point decreases.

With an external resistor between the Trim and +Sense, the output voltage set point increases.

Maximum output deviation is +10% inclusive of remote sense.

The external TRIM resistor needs to be at least 1/8W rated power.

Trim Up Equation
$$R_U = \left(\frac{V_{OUT}(100 + \Delta\%)}{1.225\Delta\%} - \frac{100 + 2\Delta\%}{\Delta\%} \right) k\Omega$$

Trim Down Equation
$$R_D = \left(\frac{100}{\Delta\%} - 2 \right) k\Omega$$

HEAT-SINK OPTIONS

-HS Option

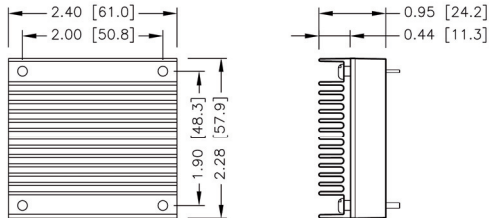

SIDE VIEW

-HS1 Option

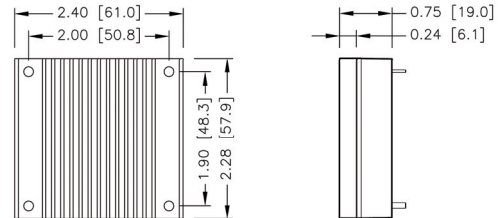

SIDE VIEW

-HS2 Option

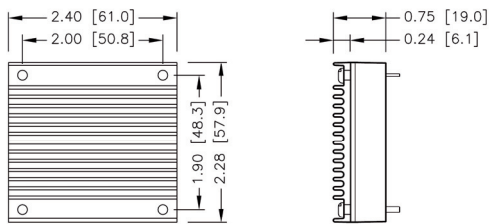

SIDE VIEW

-HS3 Option

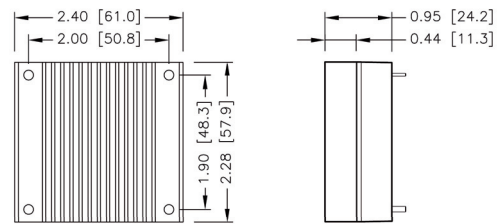

SIDE VIEW

All dimensions in inch [mm]
Tolerance: x.xx±0.02 [x.x±0.5]
x.xx±0.01 [x.x±0.25]

SYNCHRONOUS PIN

Multiple module can be synchronized together simply by connecting the module SYNC pins together.

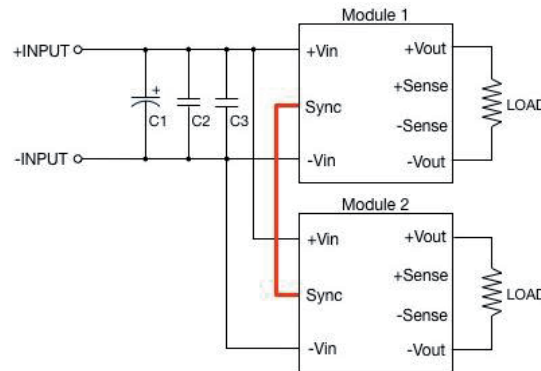

Synchronous Circuits

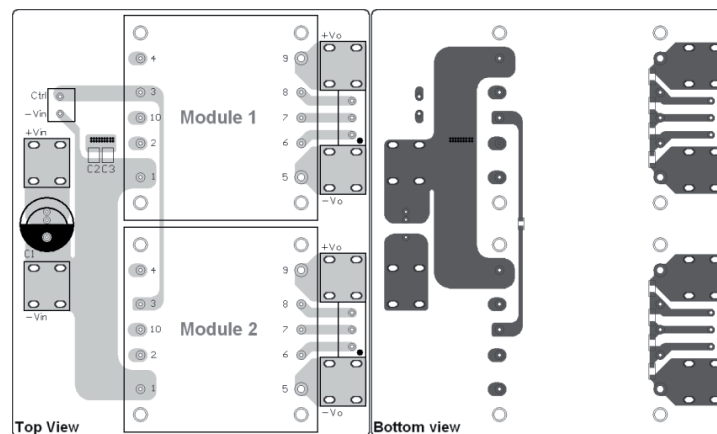

Recommended Layout

Model	Component	Value	Voltage	Reference
24Vin & 48Vin-Models	C1	220 μ F	100V	Nippon chemi-con KY-series
	C2, C3	2.2 μ F	100V	1812 MLCC
110Vin-Models	C1	150 μ F	200V	Nippon chemi-con KXJ-series
	C2, C3	1 μ F	250V	1812 MLCC

- Care should be taken to ensure the ground potential differences between modules are minimized.
- All of the modules in this configuration will be synchronized to the highest frequency module.
- Up to three modules can be synchronized using this technique.

Specifications can be changed without prior notice. Products are not intended for and must not be used in life support systems, human implantation, nuclear facilities or systems or any other application where product failure or malfunction of the component could lead to loss of life or catastrophic property damage.