

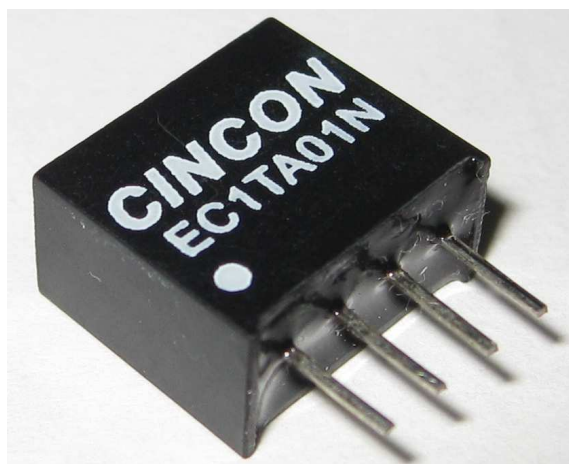

EC1TAN SERIES 1W DC-DC Converters

Application Note V11 December 2016

ISOLATED DC-DC Converter EC1TAN SERIES APPLICATION NOTE



Approved By:

Department	Approved By	Checked By	Reported By
Research and Development Department	Enoch	Danny	Joyce
		Jacky	
Engineering Department (Quality Assurance)	Jack	Benny	



EC1TAN SERIES 1W DC-DC Converters

Application Note V11 December 2016

Content

1. INTRODUCTION	3
2. DC-DC CONVERTER FEATURES	3
3. ELECTRICAL BLOCK DIAGRAM	3
4. TECHNICAL SPECIFICATIONS	4
5. MAIN FEATURES AND FUNCTIONS	6
5.1 Operating Temperature Range	6
5.2 Output Short Circuit Protection	6
6. APPLICATIONS	6
6.1 Recommended Layout PCB Footprints	6
6.2 Power De-rating curves for EC1TAN Series	7
6.3 Efficiency vs. Load Curves	8
6.4 Input Capacitance at the Power Module	10
6.5 Test Set-Up	10
6.6 Output Ripple and Noise Measurement	10
6.7 Output Capacitance	11
7. SAFETY & EMC	11
7.1 Input Fusing and Safety Considerations.	11
7.2 EMC Considerations	11
8. PART NUMBER	13
9. MECHANICAL OUTLINE DIAGRAMS	13
9.1 Mechanical Outline Diagrams	13
9.2 Packaging Details	14



EC1TAN SERIES 1W DC-DC Converters

Application Note V11 December 2016

1. Introduction

The EC1TAN series offer 1 watts of output power with Industry Standard Single-In-line Package(5&12Vin) in a 0.46 x 0.24 x 0.40inches(11.6 x 6.1 x 10.2mm) and Packages(24Vin) 0.46 x 0.30 x 0.40inches(11.6 x 7.5 x 10.2mm). The EC1TAN series have a $\pm 10\%$ input voltage range of 5Vdc, 12Vdc and 24Vdc provide a unregulated output. This series are with features as miniature size, 1000VDC of isolation and allow an operating ambient temperature range of -40°C to 85°C . All models are very suitable for telecommunications, distributed power systems, battery operated equipment, industrial, portable equipment applications.

3. Electrical Block Diagram

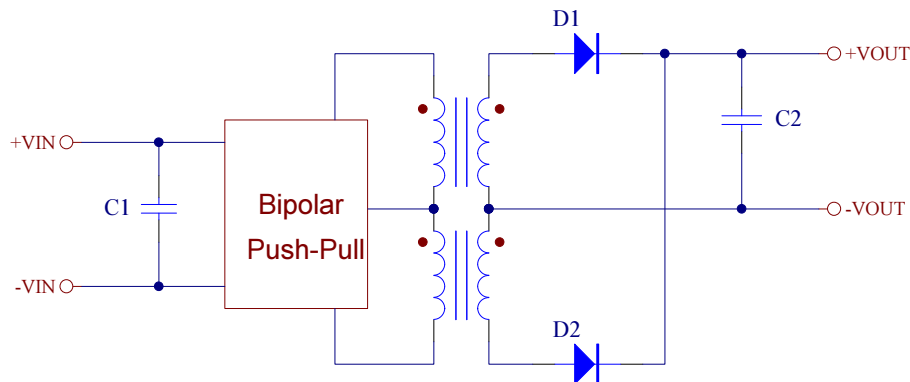

Figure1 Electrical Block Diagram

2. DC-DC Converter Features

- Industry Standard SIP Packages
- Efficiency up to 82%
- 1000VDC Isolation
- Low Cost
- Unregulated Outputs
- Low Ripple and Noise
- No Tantalum Capacitors Inside
- RoHS compliance



EC1TAN SERIES 1W DC-DC Converters

Application Note V11 December 2016

4. Technical Specifications

(All specifications are typical at nominal input, full load at 25°C unless otherwise noted.)

ABSOLUTE MAXIMUM RATINGS						
PARAMETER	NOTES and CONDITIONS	Device	Min.	Typical	Max.	Units
Input Voltage						
Continuous		EC1TA0XN EC1TA1XN EC1TA2XN	-0.7 -0.7 -0.7		5.5 13.2 26.4	Vdc
Transient	100ms	EC1TA0XN EC1TA1XN EC1TA2XN	-0.7 -0.7 -0.7		9 18 30	Vdc
Operating Ambient Temperature		All	-40		+85	°C
Storage Temperature		All	-55		+125	°C
Operating Case Temperature		All	-40		+100	°C
Input/Output Isolation Voltage	1 minute	All	1000			Vdc
INPUT CHARACTERISTICS						
PARAMETER	NOTES and CONDITIONS	Device	Min.	Typical	Max.	Units
Operating Input Voltage		EC1TA0XN EC1TA1XN EC1TA2XN	4.5 10.8 21.6	5 12 24	5.5 13.2 26.4	Vdc
Maximum Input Current	100% Load, Vin=4.5V for EC1TA0XN	EC1TA0XN		250		mA
	100% Load, Vin=10.8V for EC1TA1XN	EC1TA1XN		105		
	100% Load, Vin=21.6V for EC1TA2XN	EC1TA2XN		55		
No-Load Input Current	Vin=5Vdc	EC1TA0XN		40		mA
	Vin=12Vdc	EC1TA1XN		15		
	Vin=24Vdc	EC1TA2XN		7		
Inrush Current (I ² t)		All			0.01	A ² s
OUTPUT CHARACTERISTIC						
PARAMETER	NOTES and CONDITIONS	Device	Min.	Typical	Max.	Units
Output Voltage Set Point	Vin=Nominal Vin , Io=Io.max, Tc=25°C	Vo=5.0Vdc	4.85	5.0	5.15	Vdc
		Vo=12Vdc	11.64	12	12.36	
		Vo=15Vdc	14.55	15	15.45	
Output Voltage Regulation						
Load Regulation	Io=20% to 100%	All			±10	%
Line Regulation	For Vin Change of 1%	All			±1.2	%
Temperature Coefficient	Ta=-40°C to 85°C	All			±0.05	%/°C
Output Voltage Ripple and Noise						
Peak-to-Peak	Full Load, 20MHz bandwidth Output with 0.33uF Ceramic Capacitor	All			100	mV



EC1TAN SERIES 1W DC-DC Converters

Application Note V11 December 2016

OUTPUT CHARACTERISTIC						
PARAMETER	NOTES and CONDITIONS	Device	Min.	Typical	Max.	Units
Operating Output Current Range		Vo=5.0Vdc	0		200	mA
		Vo=12Vdc	0		84	
		Vo=15Vdc	0		67	
Over Load	Vin=Nominal Vin Output Voltage Within Vo Set Point $\pm 5\%$	All	120			%
Maximum Output Capacitance	Full load	Vo=5.0Vdc Vo=12Vdc Vo=15Vdc			220 220 220	μ F
Output Short Circuit	Momentary	All			1	Sec.
EFFICIENCY						
PARAMETER	NOTES and CONDITIONS	Device	Min.	Typical	Max.	Units
100% Load		EC1TA01N		79		%
		EC1TA02N		79		
		EC1TA03N		80		
		EC1TA11N		81		
		EC1TA12N		81		
		EC1TA13N		82		
		EC1TA21N		80		
		EC1TA22N		80		
		EC1TA23N		81		
ISOLATION CHARACTERISTICS						
PARAMETER	NOTES and CONDITIONS	Device	Min.	Typical	Max.	Units
Input to Output	1 minutes	All	1000			Vdc
Isolation Resistance		All	1000			M Ω
Isolation Capacitance		All		10		pF
FEATURE CHARACTERISTICS						
PARAMETER	NOTES and CONDITIONS	Device	Min.	Typical	Max.	Units
Switching Frequency	Vin=Nominal Vin, Full Load	EC1TA0xN EC1TA1xN		90		KHz
		EC1TA2xN		80		
GENERAL SPECIFICATIONS						
PARAMETER	NOTES and CONDITIONS	Device	Min.	Typical	Max.	Units
MTBF	Io=100% of Io,max; Ta=25°C per MIL-HDBK-217F, GB	All	1.7			M hours
Weight		EC1TA0xN EC1TA1xN		1.3		grams
		EC1TA2xN		1.7		



EC1TAN SERIES 1W DC-DC Converters

Application Note V11 December 2016

5. Main Features and Functions

5.1 Operating Temperature Range

The EC1TAN series converters can be operated by a wide ambient temperature range from -40°C to 85°C. The standard model has a plastic case and case temperature can not over 100°C at normal operating.

5.2 Output Short Circuit Protection

All different voltage models have a momentary short-circuit protection (1 Second maximum). Please notice this condition and avoid output short as much as possible.

6. Applications

6.1 Recommended Layout PCB Footprints

The system designer or the end user must ensure that other components and metal in the vicinity of the converter meet the spacing requirements to which the system is approved. Low resistance and low inductance PCB layout traces are the norm and should be used where possible. Due consideration must also be given to proper low impedance tracks between power module, input and output grounds. The recommended footprints and soldering profiles are shown as Figure 2.

5. Ramp up rate during cooling: -10.0 °C/Sec (From 260°C to 150°C)

Figure2 Recommended PCB Layout Footprint and Soldering Profile

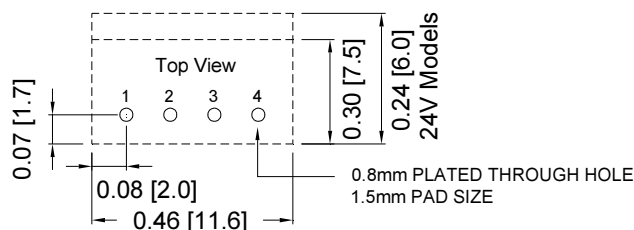

Note: Dimensions are in inches (millimeters)

Lead Free Wave Soldering Profile

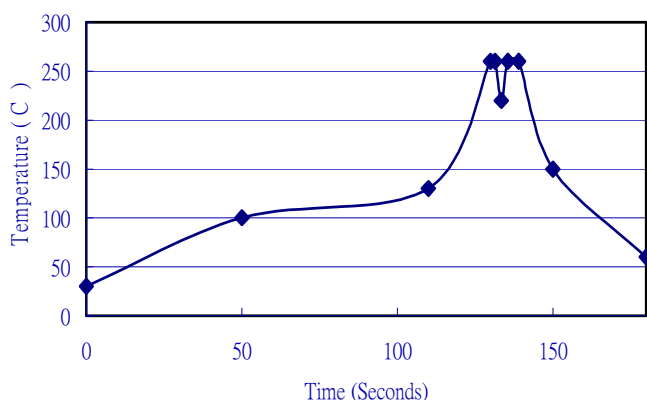

Note :

1. Soldering Materials: Sn/Cu/Ni
2. Ramp up rate during preheat: 1.4 °C/Sec (From 50°C to 100°C)
3. Soaking temperature: 0.5 °C/Sec (From 100°C to 130°C), 60±20 seconds
4. Peak temperature: 260°C, above 250°C 3~6 Seconds



EC1TAN SERIES 1W DC-DC Converters

Application Note V11 December 2016

6.2 Power De-rating curves for EC1TAN Series

Operating Ambient temperature Range: $-40^{\circ}\text{C} \sim 85^{\circ}\text{C}$

Maximum case temperature under any operating condition should not be exceed 100°C .

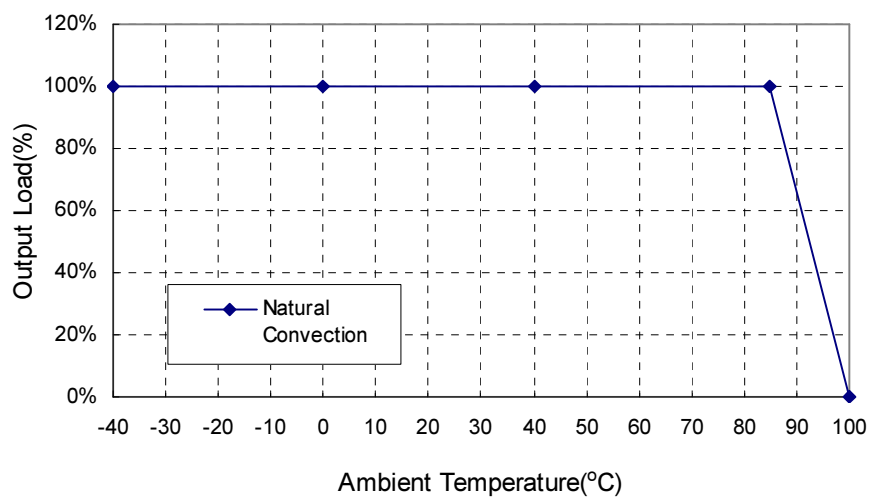

Figure3 Typical Power De-rating Curve for EC1TAN Series



EC1TAN SERIES 1W DC-DC Converters

Application Note V11 December 2016

6.3 Efficiency vs. Load Curves

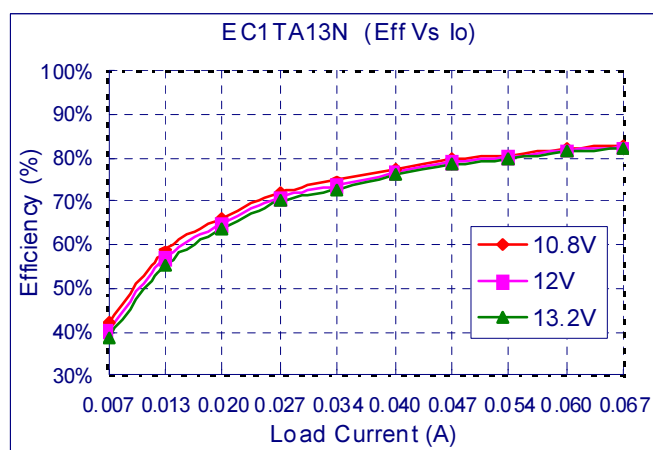
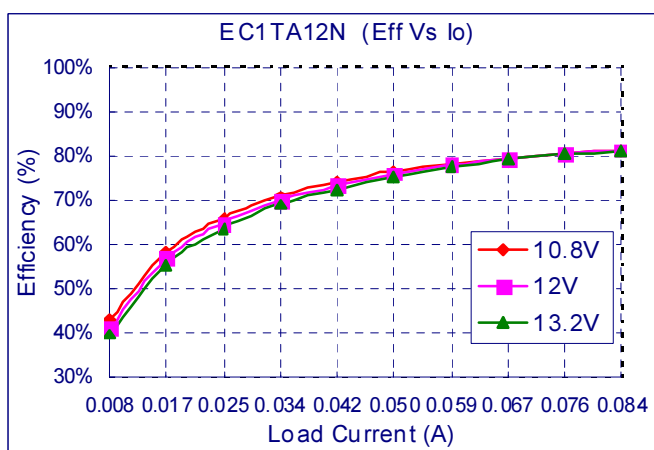
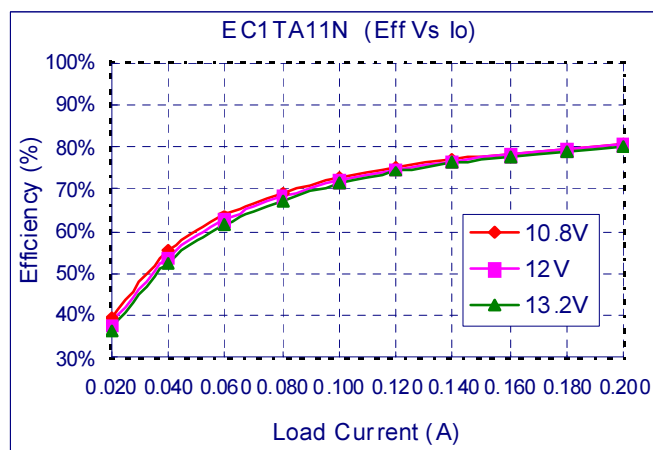
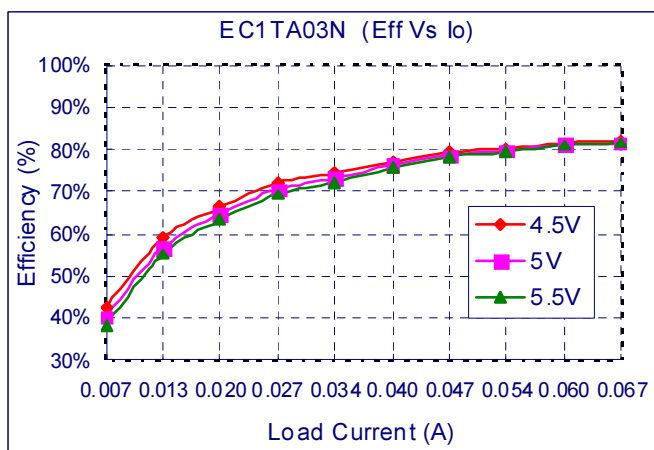
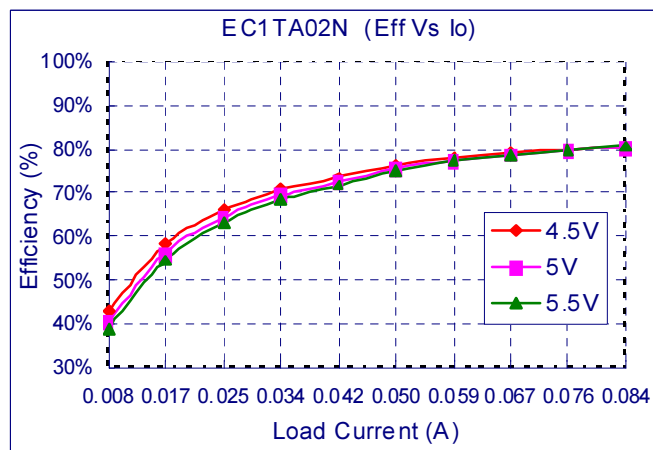
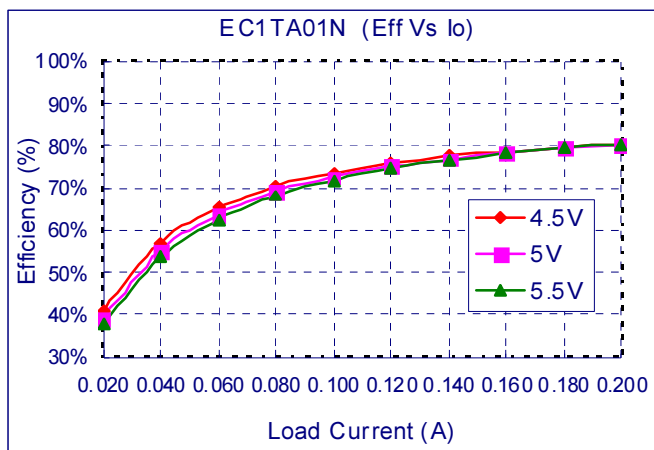



EC1TAN SERIES 1W DC-DC Converters

Application Note V11 December 2016

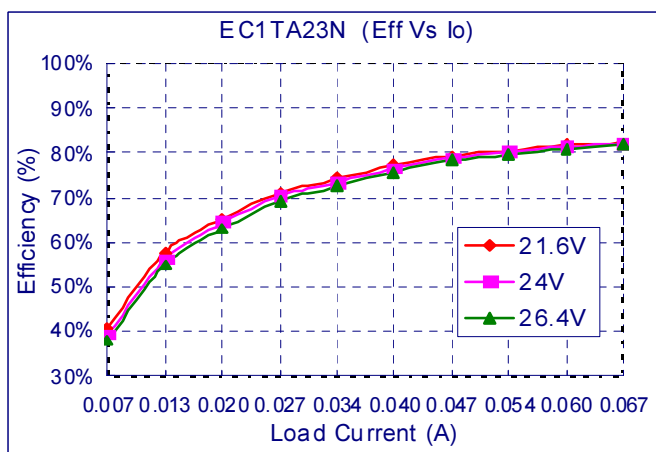
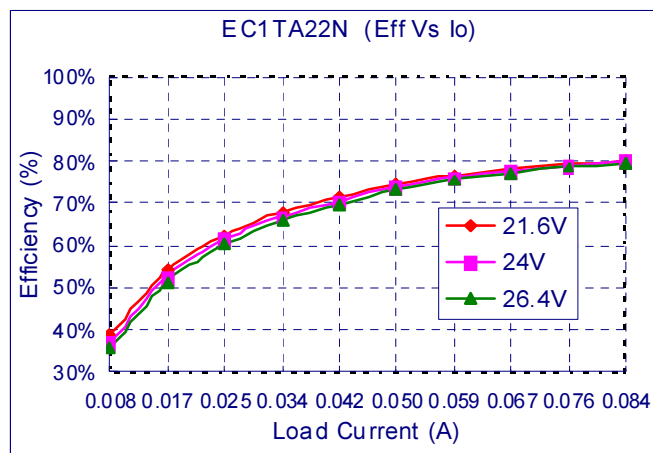
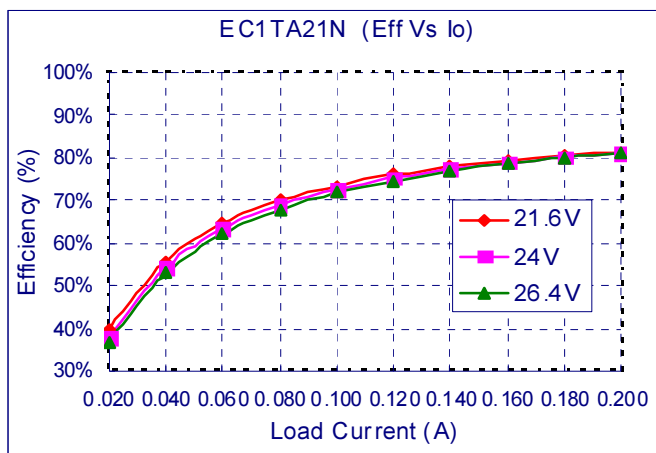



EC1TAN SERIES 1W DC-DC Converters

Application Note V11 December 2016

6.4 Input Capacitance at the Power Module

The converters must be connected to low AC source impedance. To avoid problems with loop stability source inductance should be low. Also, the input capacitors (Cin) should be placed close to the converter input pins to de-couple distribution inductance. However, the external input capacitors are chosen for suitable ripple handling capability. The input capacitors (Cin) are recommended by low ESR capacitors of 2.2uF for 5Vin and 12Vin models or 4.7uF for 24Vin models. Testing Circuit for reflected ripple current as shown in Figure4 represents typical measurement methods. C1 and L1 simulate a typical DC source impedance. The input reflected-ripple current is measured by current probe to oscilloscope with a simulated source Inductance (L1).

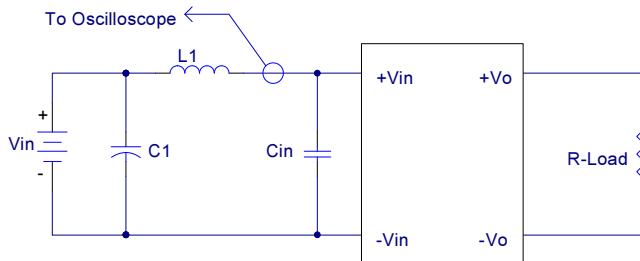

- L1: 12uF
- C1: 2.2uF Tantalum capacitor for 5Vin and 12Vin models or 4.7uF Ceramic capacitor for 24Vin models
- Cin: NC

Figure4 Input Reflected-Ripple Test Setup

6.5 Test Set-Up

The basic test set-up to measure parameters such as efficiency and load regulation is shown in Figure5. When testing the modules under any transient conditions please ensure that the transient response of the source is sufficient to power the equipment under test. We can calculate the

- Efficiency
- Load regulation and line regulation.

The value of efficiency is defined as:

$$\eta = \frac{V_o \times I_o}{V_{in} \times I_{in}} \times 100\%$$

Where: Vo is output voltage,
Io is output current,
Vin is input voltage,
Iin is input current.

The value of load regulation is defined as:

$$Load.reg = \frac{V_{FL} - V_{ML}}{V_{ML}} \times 100\%$$

Where: V_{FL} is the output voltage at full load
V_{ML} is the output voltage at 20% full load

Line regulation is per 1.0% change in input voltage.

The value of line regulation is defined as:

$$Line.reg = \frac{V_{HL} - V_{LL}}{V_{NOM}} \times 100\%$$

Where: V_{HL} is the output voltage of maximum input voltage at full load.

V_{LL} is the output voltage of minimum input voltage at full load.
V_{NOM} is the output voltage of nominal input voltage at full load.

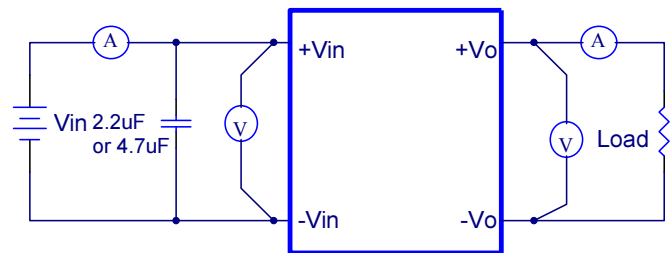

Figure5 EC1TAN Series Single output Test Setup

6.6 Output Ripple and Noise Measurement

The test set-up for noise and ripple measurements is shown in Figure6. A coaxial cable was used to prevent impedance mismatch reflections disturbing the noise readings at higher frequencies. Measurements are taken with output appropriately loaded and all ripple/noise specifications are from D.C. to 20MHz Band Width. The output ripple/noise is measured with 0.33uF ceramic capacitor across output. The ripple and noise is measured by BNC at 50mm to 75mm (2" to 3") from the module.

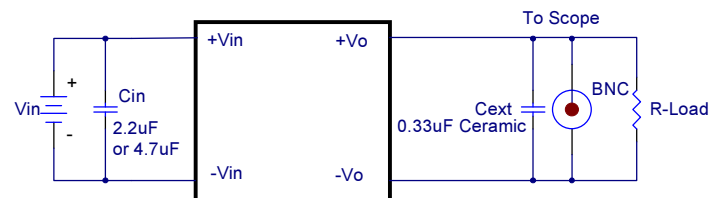

Figure6 Output Voltage Ripple and Noise Measurement Set-up



EC1TAN SERIES 1W DC-DC Converters

Application Note V11 December 2016

6.7 Output Capacitance

The EC1TAN series converters provide unconditional stability with or without external capacitors. For good transient response low ESR output capacitors should be located close to the point of load. These series converters are designed to work with load capacitance to see technical specifications.

7. Safety & EMC

7.1 Input Fusing and Safety Considerations.

The EC1TAN series converters have not an internal fuse. However, to achieve maximum safety and system protection, always use an input line fuse. We recommended a time delay fuse 0.5A for all models. Figure7 circuit is recommended by a Transient Voltage Suppressor diode across the input terminal to protect the unit against surge or spike voltage and input reverse voltage.

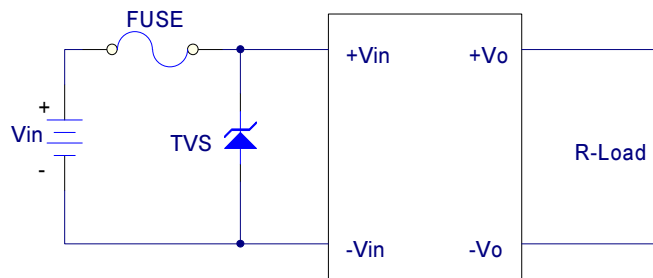

Figure7 Input Protection

7.2 EMC Considerations

EMI Test standard: EN55022 Class A and Class B Conducted Emission

Test Condition: Input Voltage: Nominal, Output Load: Full Load

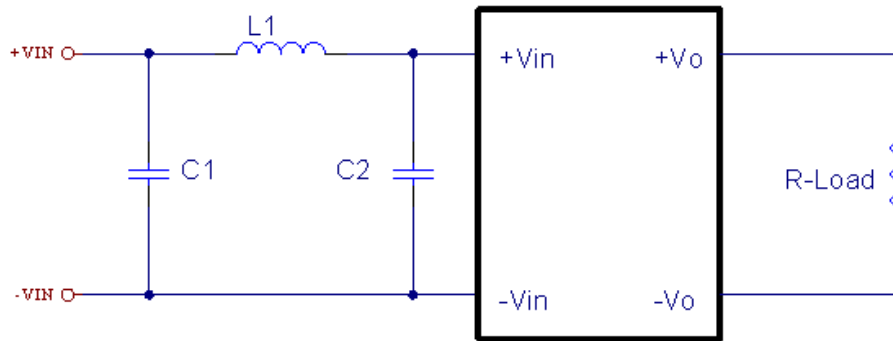

Figure8 Connection circuit for conducted EMI testing

Model No.	EN55022 class A			EN55022 class B		
	C1	C2	L1	C1	C2	L1
EC1TAN Series	4.7uF/50V 1210	4.7u/50V 1210	3.3uH	10uF/50V 1210	10uF/50V 1210	7.5uH

Note: All of capacitors are ceramic capacitors.



EC1TAN SERIES 1W DC-DC Converters

Application Note V11 December 2016

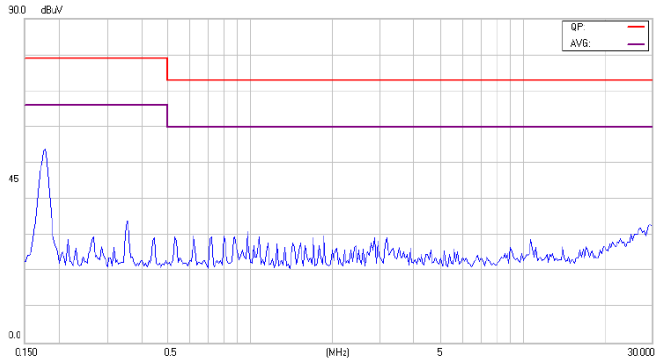

Figure9-1 EMI Conducted Class A for EC1TA01N

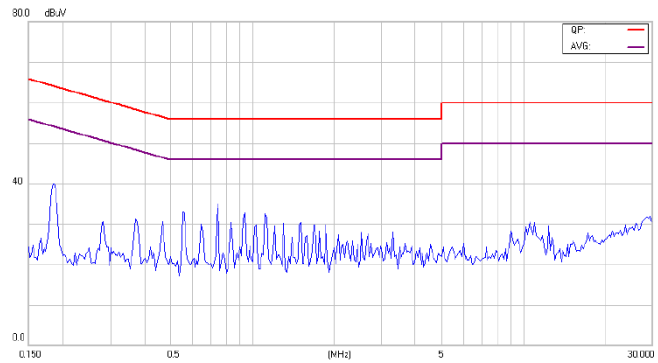

Figure9-2 EMI Conducted Class B for EC1TA01N

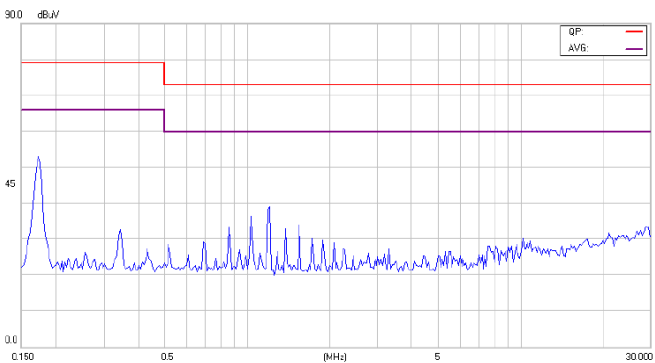

Figure10-1 EMI Conducted Class A for EC1TA11N

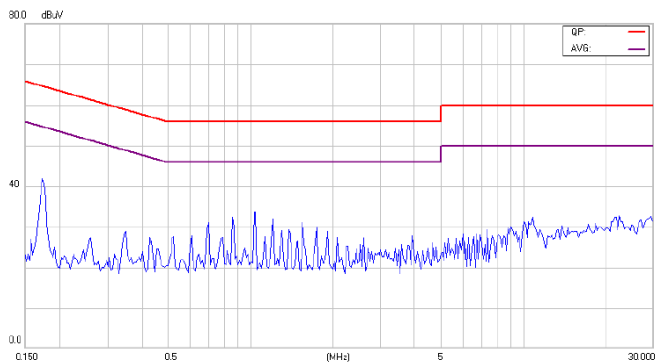

Figure10-2 EMI Conducted Class B for EC1TA11N

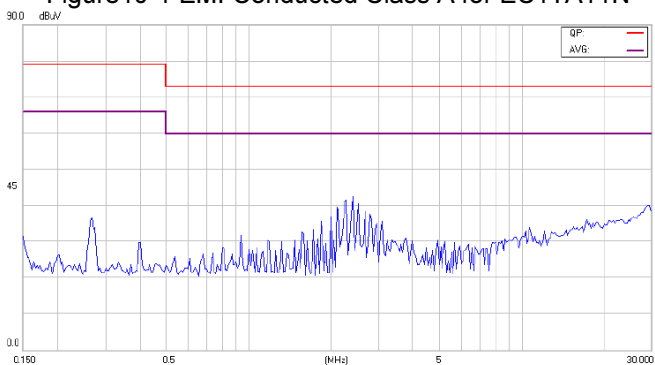

Figure11-1 EMI Conducted Class A for EC1TA21N

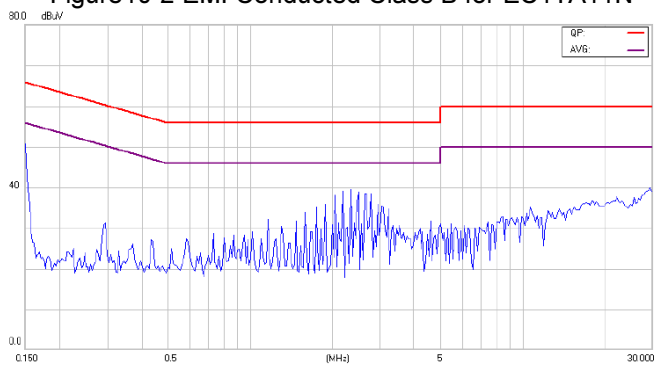

Figure11-2 EMI Conducted Class B for EC1TA21N



EC1TAN SERIES 1W DC-DC Converters

Application Note V11 December 2016

8. Part Number

EC1TA X X N

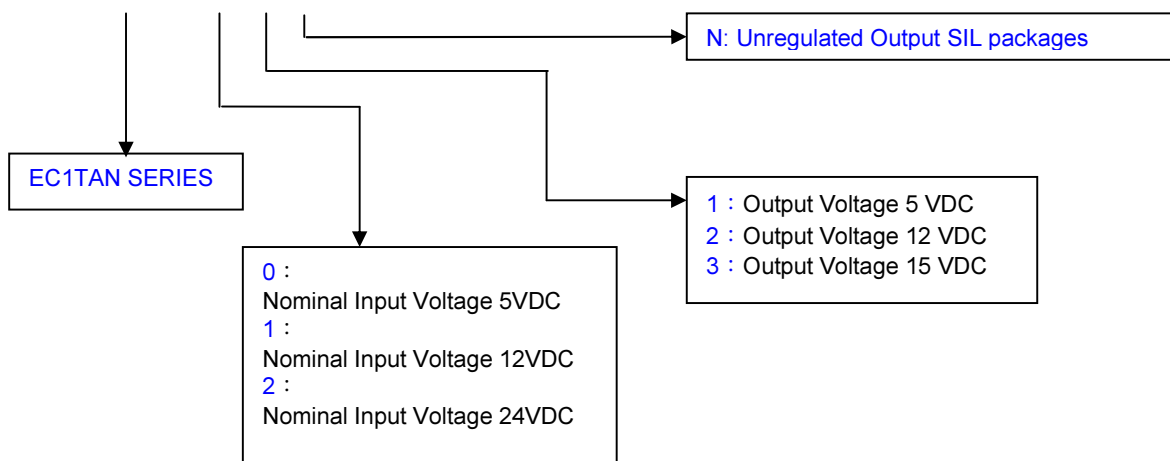

9. Mechanical Outline Diagrams

9.1 Mechanical Outline Diagrams

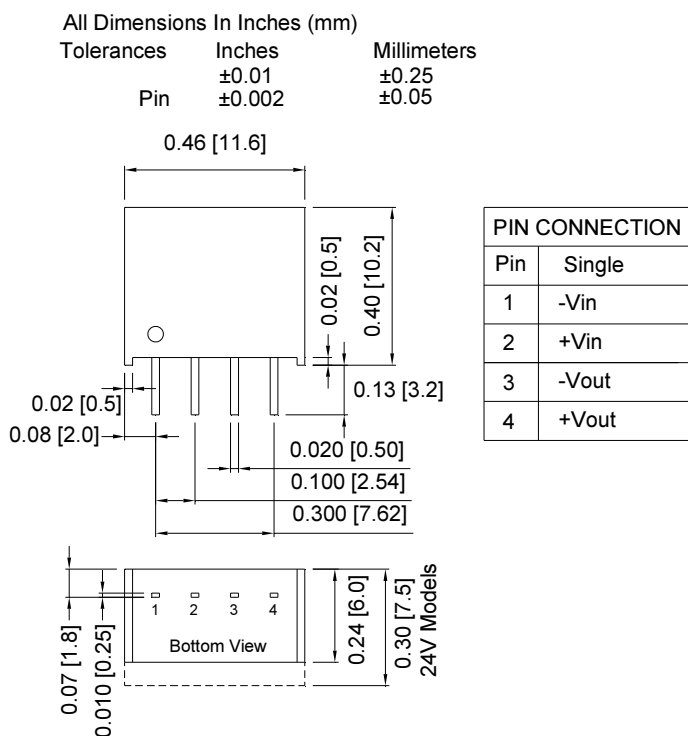

Figure12 EC1TAN Mechanical Outline Diagram



EC1TAN SERIES 1W DC-DC Converters

Application Note V11 December 2016

9.2 Packaging Details

The EC1TAN series SIL version are supplied in Tube. Modules are shipped in quantities for EC1TA0XN, EC1TA1XN 28 of 28 modules for EC1TA2XN of 26 modules (17.2*9*340mm) per Tube. Details of tube dimensions are shown below.

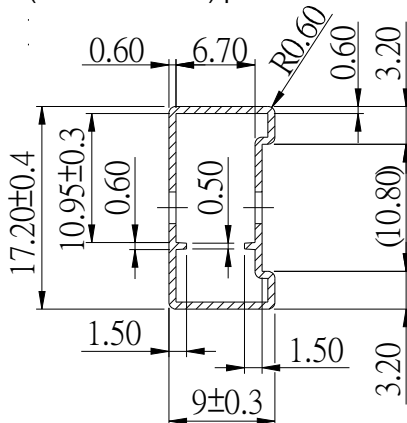

Figure13 SIL Packages Tube for EC1TA0XN and EC1TA1xN

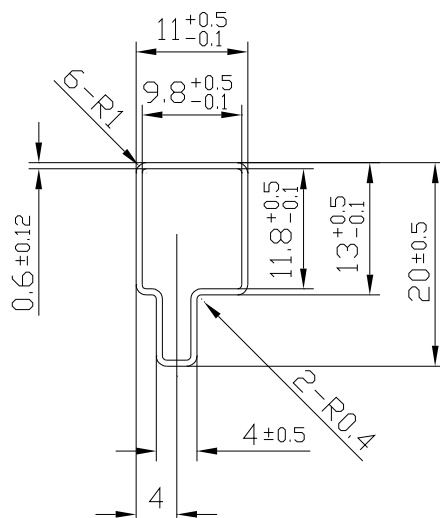

Figure14 SIL Packages Tube for EC1TA2XN

CINCON ELECTRONICS CO., LTD.

Headquarter Office:

14F, No.306, Sec.4, Hsin Yi Rd.,
 Taipei, Taiwan
 Tel: 886-2-27086210
 Fax: 886-2-27029852
 E-mail: support@cincon.com.tw
 Web Site: <http://www.cincon.com>

Factory:

No. 8-1, Fu Kong Rd.,
 Fu Hsing Industrial Park
 Fu Hsing Hsiang, ChangHua Hsien,
 Taiwan
 Tel: 886-4-7690261
 Fax: 886-4-7698031

Cincon American Office:

7770 Telegraph Road, Suite 219,
 Ventura, CA 93004
 Tel: 805-647-3006
 Fax: 805-659-3372
 E-mail: escherb@cincon.com