



# ECLB40W 33-40 Watt Isolated DC-DC Converters

## Application Note V12 November 2018

### ISOLATED DC-DC CONVERTER ECLB40W SERIES APPLICATION NOTE



Approved By:

Department	Approved By	Checked By	Written By
Research and Development Department	Enoch	Astray/James	Joyce
		Jacky	
Quality Assurance Department	Ryan	Benny	



# ECLB40W 33-40 Watt Isolated DC-DC Converters

## Application Note V12 November 2018

---

### Content

<b>1. INTRODUCTION</b>	<b>3</b>
<b>2. DC-DC CONVERTER FEATURES</b>	<b>3</b>
<b>3. ELECTRICAL BLOCK DIAGRAM</b>	<b>3</b>
<b>4. TECHNICAL SPECIFICATIONS</b>	<b>5</b>
<b>5. MAIN FEATURES AND FUNCTIONS</b>	<b>9</b>
5.1 Operating Temperature Range	9
5.2 Remote On/Off	9
5.3 UVLO (Under Voltage Lock Out)	9
5.4 Over Current Protection	9
5.5 Over Voltage Protection	9
5.6 Over-Temperature Protection (OTP)	9
5.7 Output Voltage Adjustment	9
<b>6. APPLICATIONS</b>	<b>9</b>
6.1 Recommended Layout PCB Footprints and Soldering Information	9
6.2 Power De-Rating Curves for ECLB40W Series	10
6.3 LB Heat Sinks:	11
6.4 Efficiency vs. Load Curves	12
6.5 Input Capacitance at the Power Module	14
6.6 Test Set-Up	14
6.7 Output Voltage Adjustment	14
6.8 Output Ripple and Noise Measurement	15
6.9 Output Capacitance	15
<b>7. SAFETY &amp; EMC</b>	<b>16</b>
7.1 Input Fusing and Safety Considerations.	16
7.2 EMC Considerations	16
<b>8. PART NUMBER</b>	<b>19</b>
<b>9. MECHANICAL SPECIFICATIONS</b>	<b>19</b>



# ECLB40W 33-40 Watt Isolated DC-DC Converters

## Application Note V12 November 2018

### 1. Introduction

The ECLB40W series offer 40 watts of output power in a 2.05x1.20x0.4 inches copper packages. The ECLB40W series has a 4:1 wide input voltage range of 9-36 and 18-75VDC, and provides a precisely regulated output. This series has features such as high efficiency, 1500VDC of isolation and allows an ambient operating temperature range of  $-40^{\circ}\text{C}$  to  $85^{\circ}\text{C}$  (de-rating above  $60^{\circ}\text{C}$ ). The modules are fully protected against input UVLO (under voltage lock out), output over-current, over-voltage and over-temperature and short circuit conditions. Furthermore, the standard control functions include remote on/off and adjustable output voltage. All models are very suitable for distributed power architectures, telecommunications, battery operated equipment and industrial applications.

### 2. DC-DC Converter Features

- \* 40W Isolated Output
- \* Efficiency to 91%
- \* 2.05" X1.2 X0.4" Six-Sided Shield Metal Case
- \* 4:1 Input Range
- \* Regulated Outputs
- \* Fixed Switching Frequency
- \* Low No Load Power Consumption
- \* Input Under Voltage Protection
- \* Over Current Protection
- \* Remote On/Off
- \* Continuous Short Circuit Protection
- \* No Tantalum Capacitor Inside
- \* Safety Meets UL60950-1, EN60950-1, and IEC60950-1

### 3. Electrical Block Diagram

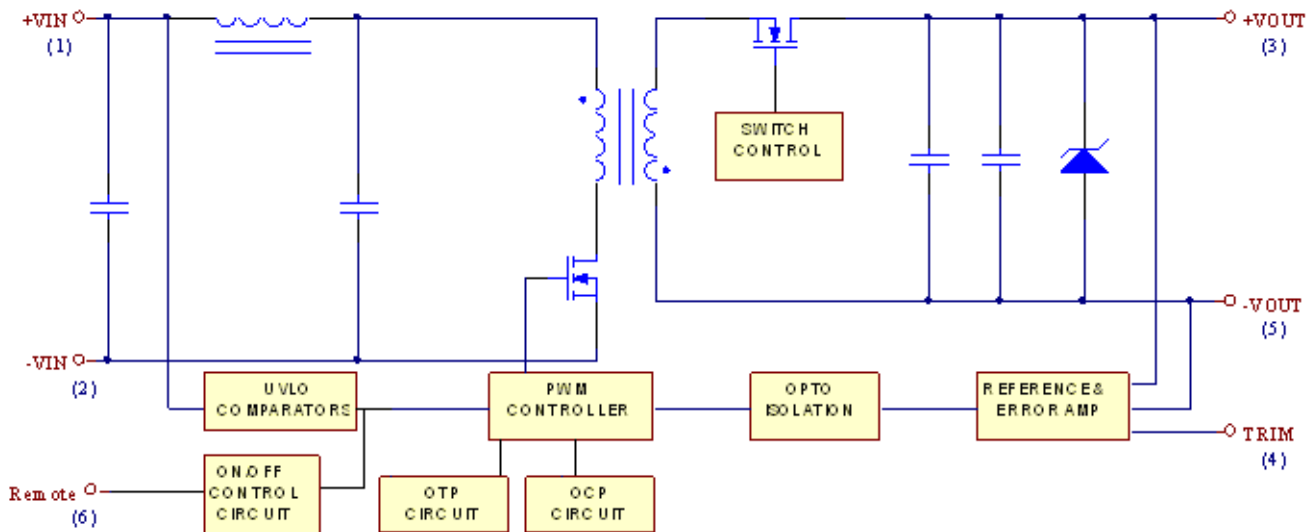

Figure 1 Electrical Block Diagram for Single Output Modules



# ECLB40W 33-40 Watt Isolated DC-DC Converters

## Application Note V12 November 2018

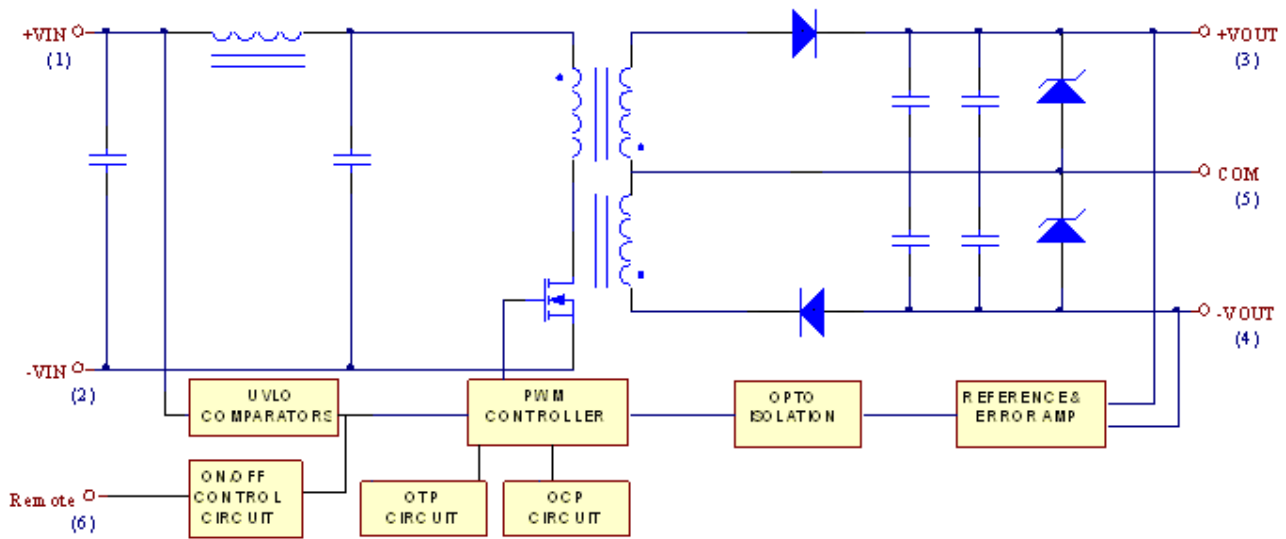

Figure 2 Electrical Block Diagram for Dual Output Modules



# ECLB40W 33-40 Watt Isolated DC-DC Converters

## Application Note V12 November 2018

### 4. Technical Specifications

(All specifications are typical at nominal input, full load at 25°C unless otherwise noted.)

#### ABSOLUTE MAXIMUM RATINGS

PARAMETER	NOTES and CONDITIONS	Device	Min.	Typical	Max.	Units
Input Voltage						
Continuous		24Vin	9	24	36	Vdc
		48Vin	18	48	75	
Transient	100ms	24Vin			50	Vdc
		48Vin			100	
Operating Ambient Temperature	Derating, above 60°C	All	-40		+85	°C
Case Temperature		All			105	°C
Storage Temperature		All	-55		+125	°C
Input/Output Isolation Voltage	1 minute	All			1500	Vdc

#### INPUT CHARACTERISTICS

PARAMETER	NOTES and CONDITIONS	Device	Min.	Typical	Max.	Units
Operating Input Voltage		24Vin	9	24	36	Vdc
		48Vin	18	48	75	
Input Under Voltage Lockout						
Turn-On Voltage Threshold		24Vin	8	8.5	8.8	V <sub>dc</sub>
		48Vin	16.5	17	17.5	
Turn-Off Voltage Threshold		24Vin	7.7	8	8.3	V <sub>dc</sub>
		48Vin	15.5	16	16.5	
Lockout Hysteresis Voltage		24Vin		0.5		V <sub>dc</sub>
		48Vin		1		
Maximum Input Current	100% Load, Vin=9V	24Vin		5200		mA
	100% Load, Vin=18V	48Vin		2600		
No-Load Input Current	Vin=24V	24S33		8		mA
		24S05		8		
		24S12		10		
		24S15		10		
		24D12		10		
		24D15		10		
	Vin=48V	48S33		6		
		48S05		6		
		48S12		8		
		48S15		8		
		48D12		8		
		48D15		8		
Inrush Current (I <sup>2</sup> t)	As per ETS300 132-2	All			0.1	A <sup>2</sup> s
Input Reflected-Ripple Current	P-P thru 12uH inductor, 5Hz to 20MHz	All			30	mA



# ECLB40W 33-40 Watt Isolated DC-DC Converters

## Application Note V12 November 2018

### OUTPUT CHARACTERISTIC

PARAMETER	NOTES and CONDITIONS	Device	Min.	Typical	Max.	Units
Output Voltage Set Point	Vin=nominal input, Io= Io <sub>max</sub> .	Vo=3.3V	3.2505	3.3	3.3495	Vdc
		Vo=5.0V	4.925	5	5.075	
		Vo=12V	11.82	12	12.18	
		Vo=15V	14.775	15	15.225	
		Vo=±12V	11.82	12	12.18	
		Vo=±15V	14.775	15	15.225	
Output Voltage Balance	Vin=nominal input, Io=Io <sub>max</sub> .	Dual			±1.0	%
Output Voltage Regulation						
Load Regulation	Io=full load to min. Load	Single Dual			±0.5 ±0.5	%
Line Regulation	Vin=high line to low line, full Load	Single Dual			±0.2 ±0.2	%
Cross Regulation	Load cross variation 10%/100%	Dual			±5	%
Temperature Coefficient	Tc=-40°C to 85°C	All			±0.02	%/°C
Output Voltage Ripple and Noise 5Hz to 20MHz bandwidth						
Peak-to-Peak	Full Load, Measured with 1uF MLCC	Vo=3.3V			100	mV
		Vo=5.0V				
		Vo=12V			150	
		Vo=15V				
		Vo=±12V				
		Vo=±15V				
Operating Output Current Range		Vo=3.3V	0		10000	mA
		Vo=5.0V			8000	
		Vo=12V			3333	
		Vo=15V			2666	
		Vo=±12V			±1667	
		Vo=±15V			±1333	
Output DC Current-Limit Inception	Vo=90% V <sub>O, nominal</sub>	All	110	135	165	%
Maximum Output Capacitance	Full load (resistive)	Vo=3.3V			10000	uF
		Vo=5.0V			8000	
		Vo=12V			3300	
		Vo=15V			2700	
		Vo=±12V			1650	
		Vo=±15V			1350	

### DYNAMIC CHARACTERISTICS

PARAMETER	NOTES and CONDITIONS	Device	Min.	Typical	Max.	Units
Output Voltage Current Transient						
Step Change in Output Current	75% to 100% of Io <sub>max</sub> .	All			±5	%
Setting Time (within 1% Vonominal)	di/dt=0.1A/us	All			250	us
Turn-On Delay and Rise Time						
Turn-On Delay Time, From On/Off Control	Von/off to 10%Vo, set	All		7		ms
Turn-On Delay Time, From Input	Vin, min. to 10%Vo, set	All		7		ms
Output Voltage Rise Time	10%Vo, set to 90%Vo, set	All		8		ms



# ECLB40W 33-40 Watt Isolated DC-DC Converters

## Application Note V12 November 2018

### EFFICIENCY

PARAMETER	NOTES and CONDITIONS	Device	Min.	Typical	Max.	Units	
100% Load	Vin=12V	24S33		88.5		%	
		24S05		89.5			
		24S12		90.5			
		24S15		90.5			
		24D12		89.5			
		24D15		90			
	Vin=24V	48S33		89			%
		48S05		90			
		48S12		91.5			
		48S15		91			
		48D12		90			
		48D15		90.5			
	Vin=24V	24S33		90		%	
		24S05		90.5			
		24S12		91			
		24S15		90.5			
		24D12		89			
		24D15		89.5			
	Vin=48V	48S33		90			%
		48S05		90.5			
		48S12		90.5			
		48S15		90.5			
		48D12		89.5			
		48D15		90			

### ISOLATION CHARACTERISTICS

PARAMETER	NOTES and CONDITIONS	Device	Min.	Typical	Max.	Units
Input to Output	1 minutes	All			1500	Vdc
Isolation Resistance		All	1000			MΩ
Isolation Capacitance	Input/Output	All		1500		pF
	Input/Case			1000		
	Output/Case					

### FEATURE CHARACTERISTICS

PARAMETER	NOTES and CONDITIONS	Device	Min.	Typical	Max.	Units
Switching Frequency				300		KHz
On/Off Control, Positive Remote On/Off logic						
Logic Low (Module Off)	Von/off at Ion/off=1.0mA	All	0		1.2	V
Logic High (Module On)	Von/off at Ion/off=0.1uA	All	3.5 or Open Circuit		75	V
On/Off Current (for both remote on/off logic)	Ion/off at Von/off=0.0V	All		0.3	1	mA
Leakage Current (for both remote on/off logic)	Logic high, Von/off=15V	All			30	uA
Off Converter Input Current	Shutdown input idle current	All		4	10	mA
Output Voltage Trim Range	Pout=maximum rated power	All	-10		+10	%



# ECLB40W 33-40 Watt Isolated DC-DC Converters

## Application Note V12 November 2018

PARAMETER	NOTES and CONDITIONS	Device	Min.	Typical	Max.	Units
Output Over Voltage Protection	Zener or TVS clamp	Vo=3.3V Vo=5.0V Vo=12V Vo=15V Vo=±12V Vo=±15V		3.9 6.2 15 18 ±15 ±18		Vdc
Over-Temperature Shutdown		All		110		°C

### GENERAL SPECIFICATIONS

PARAMETER	NOTES and CONDITIONS	Device	Min.	Typical	Max.	Units
MTBF	Io=100% of Io.max.; Ta=25°C per MIL-HDBK-217F	All		1400		K hours
Weight		All		36		grams





# ECLB40W 33-40 Watt Isolated DC-DC Converters

## Application Note V12 November 2018

### 5. Main Features and Functions

#### 5.1 Operating Temperature Range

The ECLB40W series converters can be operated by a wide ambient temperature range from  $-40^{\circ}\text{C}$  to  $85^{\circ}\text{C}$  (de-rating above  $60^{\circ}\text{C}$ ). The standard model has a copper case and case temperature can not over  $105^{\circ}\text{C}$  at normal operating.

#### 5.2 Remote On/Off

The remote on/off input feature of the converter allows external circuitry to turn the converter on or off. Active-high remote on/off is available as standard. The converter is turned on if the remote on/off pin is high ( $>3.5\text{Vdc}$  to  $75\text{Vdc}$  or open circuit). Setting the pin low ( $0$  to  $<1.2\text{Vdc}$ ) will turn the converter 'Off'. The signal level of the remote on/off input is defined with respect to  $-V_{in}$ . If not using the remote on/off pin, leave the pin open (module will be on).

#### 5.3 UVLO (Under Voltage Lock Out)

Input under voltage lockout is standard on the ECLB40W unit. The unit will shut down when the input voltage drops below a threshold, and the unit will operate when the input voltage goes above the upper threshold.

#### 5.4 Over Current Protection

All models have internal over current and continuous short circuit protection. The unit operates normally once the fault condition is removed. At the point of current limit inception, the converter will go into hiccup mode protection.

#### 5.5 Over Voltage Protection

The over-voltage protection consists of a zener diode to limiting the out voltage.

#### 5.6 Over-Temperature Protection (OTP)

The ECLB40W series converters are equipped with non-latching over-temperature protection. If the temperature exceeds a threshold of  $110^{\circ}\text{C}$  (typical) the converter will shut down, disabling the output. When the temperature has decreased the converter will automatically restart. The over-temperature condition can be induced by a variety of reasons such as external overload condition or a system fan failure.

#### 5.7 Output Voltage Adjustment

Section 6.6 describes in detail how to trim the output voltage with respect to its set point. The output voltage on all models is adjustable within the range of  $+10\%$  to  $-10\%$ . (Single output models only)

### 6. Applications

#### 6.1 Recommended Layout PCB Footprints and Soldering Information

The system designer or the end user must ensure that other components and metal in the vicinity of the converter meet the spacing requirements to which the system is approved. Low resistance and low inductance PCB layout traces are the norm and should be used where possible. Due consideration must also be given to proper low impedance tracks between power module, input and output grounds. The recommended footprints and soldering profiles are shown below.

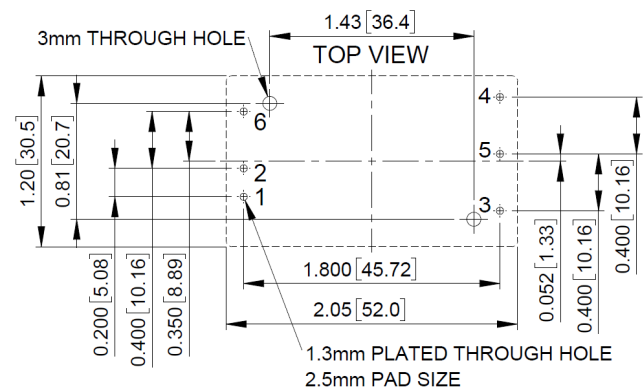

Note: Dimensions are in inches (millimeters)

#### Lead Free Wave Soldering Profile

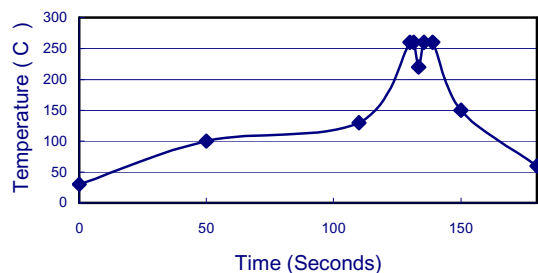

Note :

1. Soldering Materials: Sn/Cu/Ni
2. Ramp up rate during preheat:  $1.4^{\circ}\text{C}/\text{Sec}$  (From  $50^{\circ}\text{C}$  to  $100^{\circ}\text{C}$ )
3. Soaking temperature:  $0.5^{\circ}\text{C}/\text{Sec}$  (From  $100^{\circ}\text{C}$  to  $130^{\circ}\text{C}$ ),  $60\pm 20$  seconds
4. Peak temperature:  $260^{\circ}\text{C}$ , above  $250^{\circ}\text{C}$  3~6 Seconds
5. Ramp up rate during cooling:  $-10.0^{\circ}\text{C}/\text{Sec}$  (From  $260^{\circ}\text{C}$  to  $150^{\circ}\text{C}$ )



# ECLB40W 33-40 Watt Isolated DC-DC Converters

## Application Note V12 November 2018

### 6.2 Power De-Rating Curves for ECLB40W Series

Operating Ambient temperature Range:  $-40^{\circ}\text{C} \sim 85^{\circ}\text{C}$  (derating above  $60^{\circ}\text{C}$ ).

Maximum case temperature under any operating condition should not exceed  $105^{\circ}\text{C}$ .

Typical Derating curve for Natural Convection

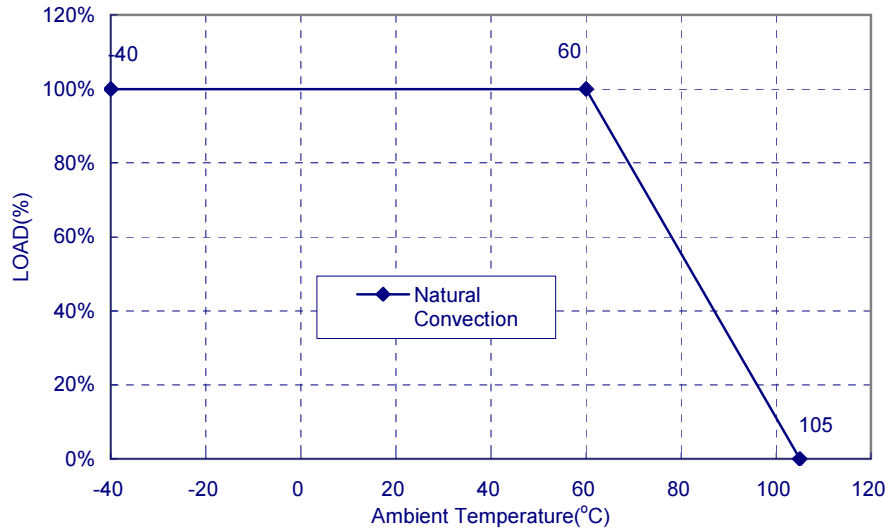



# ECLB40W 33-40 Watt Isolated DC-DC Converters

## Application Note V12 November 2018

### 6.3 LB Heat Sinks:

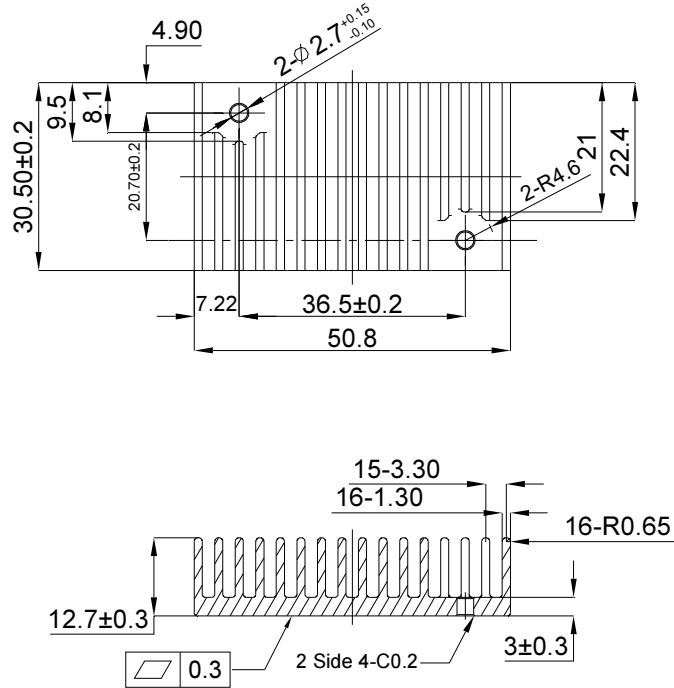

#### **M-C655 (G6620790202)**

##### **Transverse Heat Sink**

All Dimensions in mm

Rca: 8.99°C/W (typ.), At natural convection



# ECLB40W 33-40 Watt Isolated DC-DC Converters

## Application Note V12 November 2018

### 6.4 Efficiency vs. Load Curves

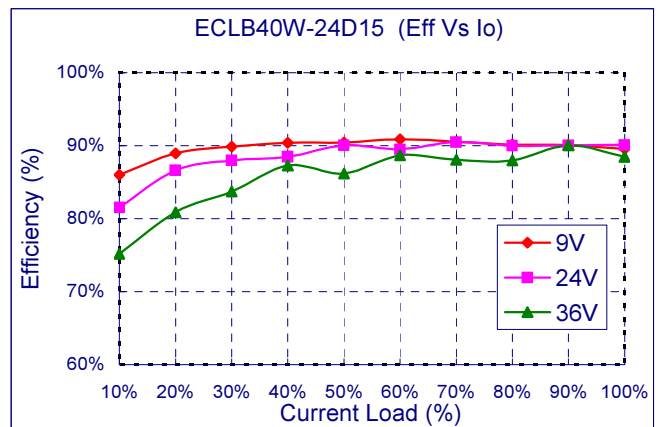
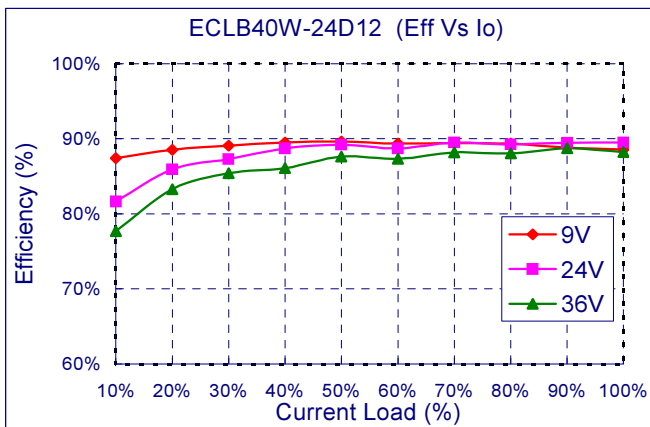
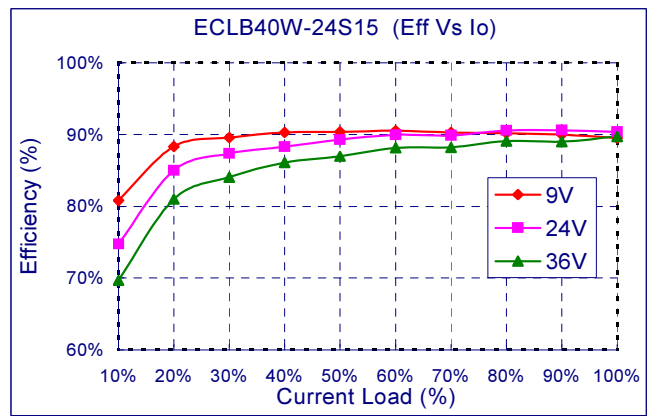
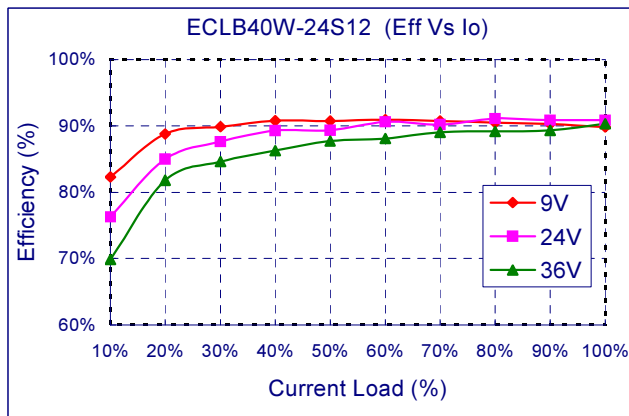
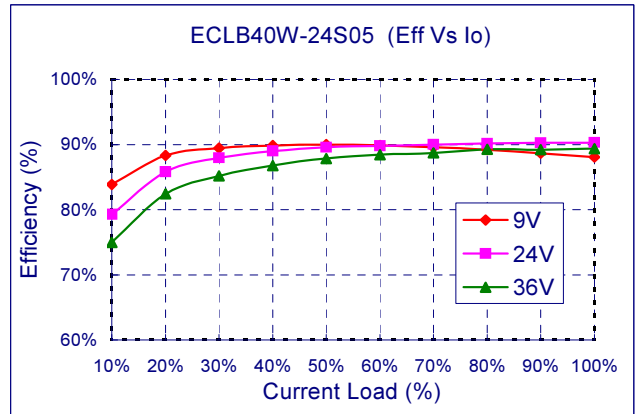
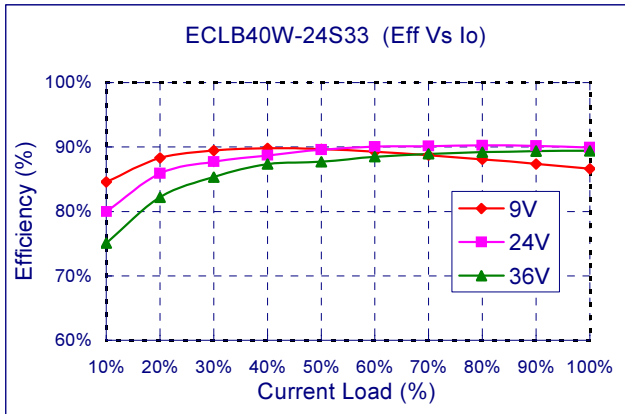



# ECLB40W 33-40 Watt Isolated DC-DC Converters

## Application Note V12 November 2018

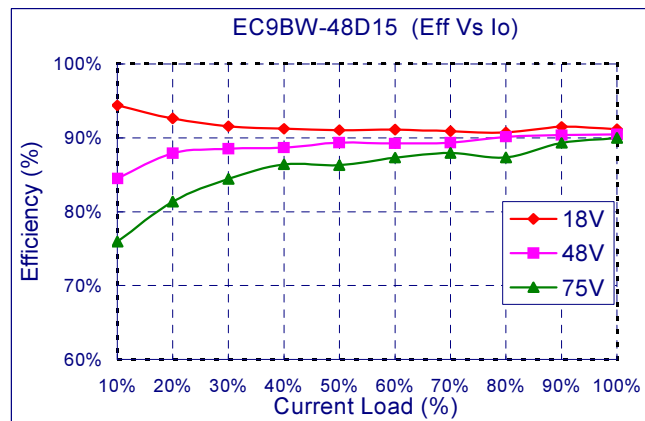
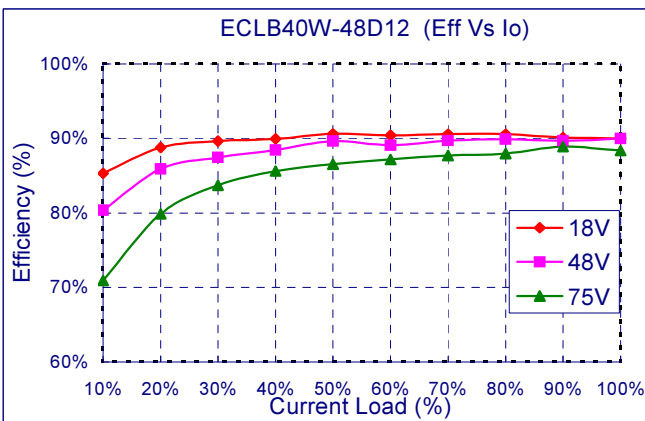
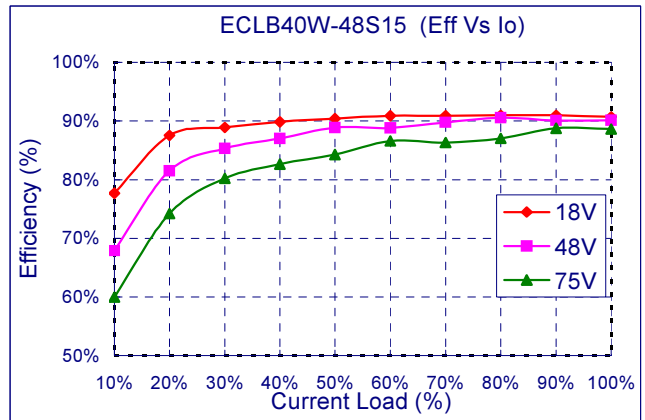
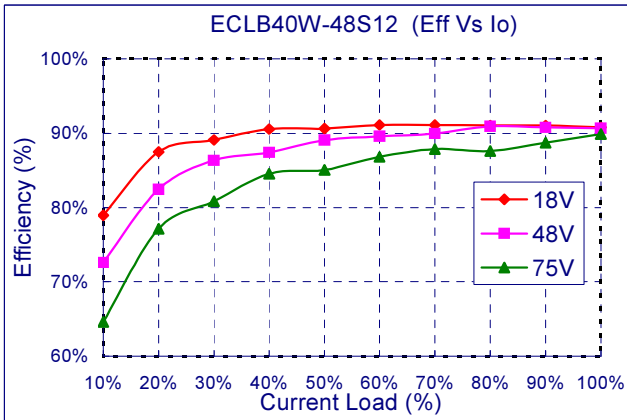
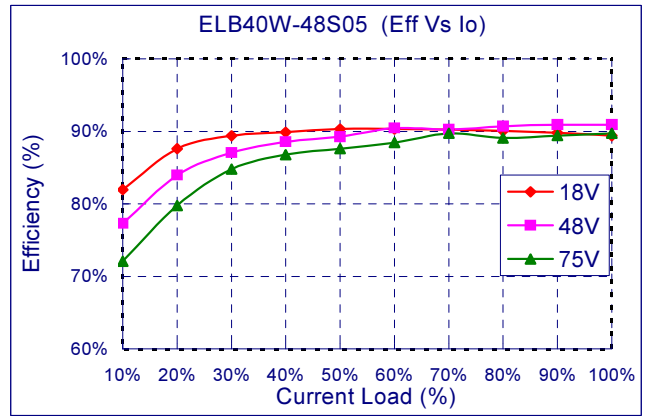
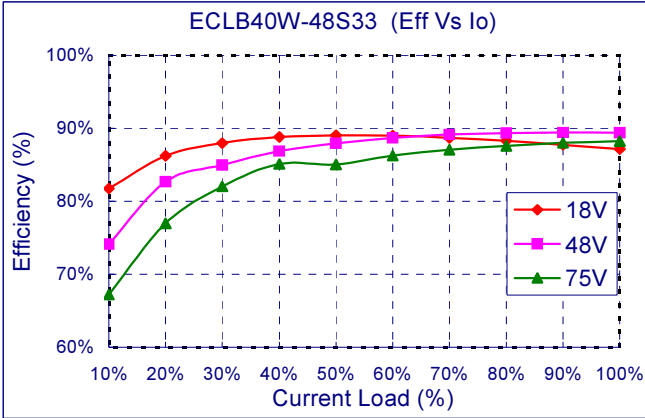



# ECLB40W 33-40 Watt Isolated DC-DC Converters

## Application Note V12 November 2018

### 6.5 Input Capacitance at the Power Module

The converters must be connected to low AC source impedance. To avoid problems with loop stability source inductance should be low. Also, the input capacitors (Cin) should be placed close to the converter input pins to de-couple distribution inductance. However, the external input capacitors are chosen for suitable ripple handling capability. Low ESR capacitors are good choice. Circuit as shown in Figure 5 represents typical measurement methods for reflected ripple current. C1 and L1 simulate a typical DC source impedance. The input reflected-ripple current is measured by current probe to oscilloscope with a simulated.

source Inductance (L1).

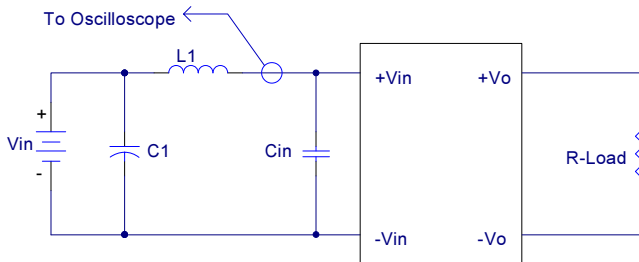

L1: 12uH  
 C1: None  
 Cin: 33uF ESR<0.7ohm @100KHz

Figure 5 Input Reflected-Ripple Test Setup

### 6.6 Test Set-Up

The basic test set-up to measure parameters such as efficiency and load regulation is shown in Figure 6. When testing the modules under any transient conditions please ensure that the transient response of the source is sufficient to power the equipment under test. We can calculate the

- Efficiency
- Load regulation and line regulation.

The value of efficiency is defined as:

$$\eta = \frac{V_O \times I_O}{V_{IN} \times I_{IN}} \times 100\%$$

Where

$V_O$  is output voltage,  
 $I_O$  is output current,  
 $V_{IN}$  is input voltage,  
 $I_{IN}$  is input current.

The value of load regulation is defined as:

$$Load.reg = \frac{V_{FL} - V_{NL}}{V_{NL}} \times 100\%$$

Where

$V_{FL}$  is the output voltage at full load  
 $V_{NL}$  is the output voltage at 10% load

The value of line regulation is defined as:

$$Line.reg = \frac{V_{HL} - V_{LL}}{V_{LL}} \times 100\%$$

Where

$V_{HL}$  is the output voltage of maximum input voltage at full load.

$V_{LL}$  is the output voltage of minimum input voltage at full load.

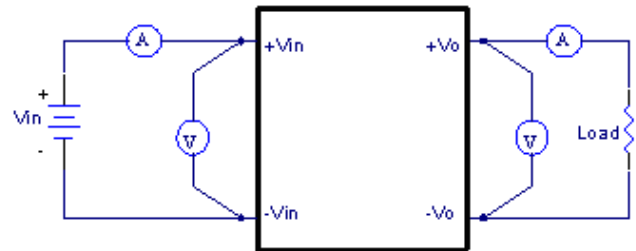

Figure 6 ECLB40W Series Test Setup

### 6.7 Output Voltage Adjustment

In order to trim the voltage up or down one needs to connect the trim resistor either between the trim pin and -Vo for trim-up and between trim pin and +Vo for trim-down. The output voltage trim range is  $\pm 10\%$ . (Single output models only) This is shown in Figure 7 and 8:

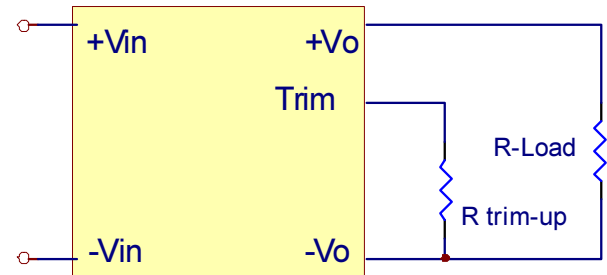

Figure 7 Trim-up Voltage Setup

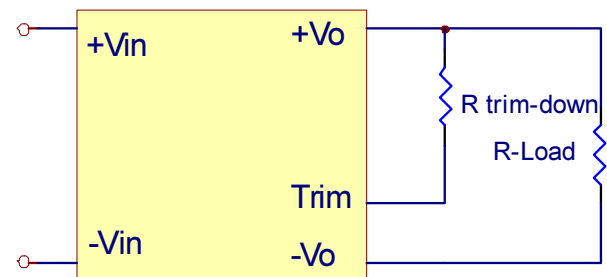

Figure 8 Trim-down Voltage Setup



# ECLB40W 33-40 Watt Isolated DC-DC Converters

## Application Note V12 November 2018

### 1. The value of $R_{trim-up}$ defined as:

$$R_{trim-up} = \left( \frac{V_r \times R1 \times (R2 + R3)}{(V_o - V_{o,nom}) \times R2} \right) - R_t \text{ (K}\Omega\text{)}$$

Where

$R_{trim-up}$  is the external resistor in Kohm.  
 $V_{o,nom}$  is the nominal output voltage.  
 $V_o$  is the desired output voltage.  
 $R1, R_t, R2, R3$  and  $V_r$  are internal to the unit and are defined in Table 1.

Table 1 – Trim up and Trim down Resistor Values

Model Number	Output Voltage(V)	R1 (KΩ)	R2 (KΩ)	R3 (KΩ)	Rt (KΩ)	Vr (V)
ECLB40W24S33 ECLB40W48S33	3.3	2.74	1.8	0.27	9.1	1.24
ECLB40W24S05 ECLB40W48S05	5.0	2.32	2.32	0	8.2	2.5
ECLB40W24S12 ECLB40W48S12	12.0	6.8	2.4	2.32	22	2.5
ECLB40W24S15 ECLB40W48S15	15.0	8.06	2.4	3.9	27	2.5

For example, to trim-up the output voltage of 5.0V module (ECLB40W-24S05) by 10% to 5.5V,  $R_{trim-up}$  is calculated as follows:

$$\begin{aligned} V_o - V_{o,nom} &= 5.5 - 5.0 = 0.5V \\ R1 &= 2.32 \text{ K}\Omega \\ R2 &= 2.32 \text{ K}\Omega \\ R3 &= 0 \text{ K}\Omega \\ R_t &= 8.2 \text{ K}\Omega, \\ V_r &= 2.5 \text{ V} \end{aligned}$$

$$R_{trim-up} = \left( \frac{2.5 \times 2.32 \times (2.32 + 0)}{0.5 \times 2.32} \right) - 8.2 = 3.4 \text{ (K}\Omega\text{)}$$

### 2. The value of $R_{trim-down}$ defined as:

$$R_{trim-down} = R1 \times \left( \frac{V_r \times R1}{(V_{o,nom} - V_o) \times R2} - 1 \right) - R_t \text{ (K}\Omega\text{)}$$

Where

$R_{trim-down}$  is the external resistor in Kohm.  
 $V_{o,nom}$  is the nominal output voltage.  
 $V_o$  is the desired output voltage.  
 $R1, R_t, R2, R3$  and  $V_r$  are internal to the unit and are defined in Table 1

For example, to trim-down the output voltage of 5.0V module (ECLB40W-12S05) by 10% to 4.5V,  $R_{trim-down}$  is calculated as follows:

$$\begin{aligned} V_{o,nom} - V_o &= 5.0 - 4.5 = 0.5V \\ R1 &= 2.32 \text{ K}\Omega \\ R2 &= 2.32 \text{ K}\Omega \\ R3 &= 0 \text{ K}\Omega \\ R_t &= 8.2 \text{ K}\Omega \\ V_r &= 2.5 \text{ V} \end{aligned}$$

$$R_{trim-down} = 2.32 \times \left( \frac{2.5 \times 2.32}{0.5 \times 2.32} - 1 \right) - 8.2 = 1.08 \text{ (K}\Omega\text{)}$$

### 6.8 Output Ripple and Noise Measurement

The test set-up for noise and ripple measurements is shown in Figure 9. A coaxial cable was used to prevent impedance mismatch reflections disturbing the noise readings at higher frequencies. Measurements are taken with output appropriately loaded and all ripple/noise specifications are from 5Hz to 20MHz bandwidth.

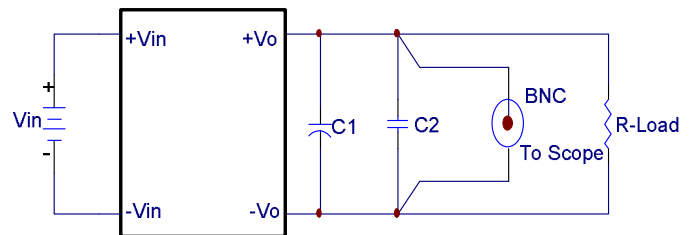

Note: C1: none

C2: 1uF ceramic capacitor

Figure 9 Output Voltage Ripple and Noise Measurement Set-Up

### 6.9 Output Capacitance

The ECLB40W series converters provide unconditional stability with or without external capacitors. For good transient response low ESR output capacitors should be located close to the point of load. These series converters are designed to work with load capacitance to see technical specifications.



# ECLB40W 33-40 Watt Isolated DC-DC Converters

## Application Note V12 November 2018

### 7. Safety & EMC

#### 7.1 Input Fusing and Safety Considerations.

The ECLB40W series converters have not an internal fuse. However, to achieve maximum safety and system protection, always use an input line fuse. We recommended a time delay fuse 6A for 24Vin models and 3A for 48Vin modules. Figure 10 circuit is recommended by a Transient Voltage Suppressor diode across the input terminal to protect the unit against surge or spike voltage and input reverse voltage.

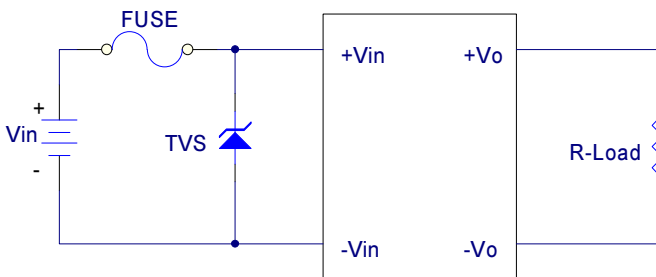

Figure 10 Input Protection

#### 7.2 EMC Considerations

EMI Test standard: EN55022 Class A Conducted Emission  
 Test Condition: Input Voltage: Nominal, Output Load: Full Load

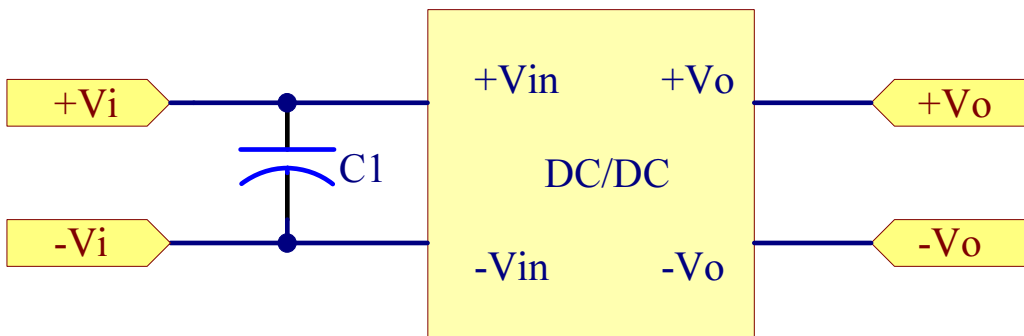

Figure 11 Connection circuit for conducted EMI testing

Model No.	C1	Model No.	C1
ECLB40W-24S33	100uF/50V ESR<0.17	ECLB40W-48S33	47uF/100V ESR<0.17
ECLB40W-24S05		ECLB40W-48S05	
ECLB40W-24S12		ECLB40W-48S12	
ECLB40W-24S15		ECLB40W-48S15	
ECLB40W-24D12		ECLB40W-48D12	
ECLB40W-24D15		ECLB40W-48D15	

Note: The C1 aluminum capacitors





# ECLB40W 33-40 Watt Isolated DC-DC Converters

## Application Note V12 November 2018

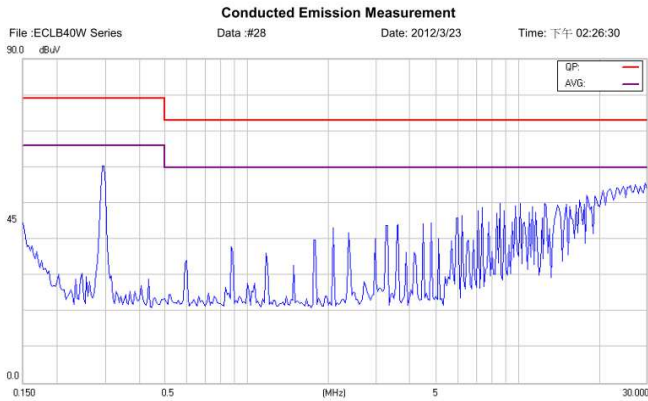

Figure 12 Conducted Class A of ECLB40W-24S33

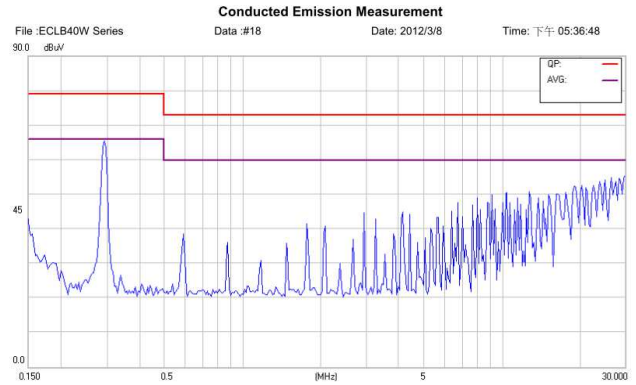

Figure 13 Conducted Class A of ECLB40W-24S05

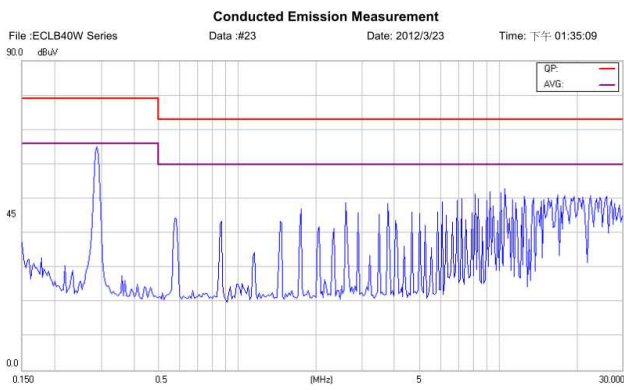

Figure 14 Conducted Class A of ECLB40W-24S12

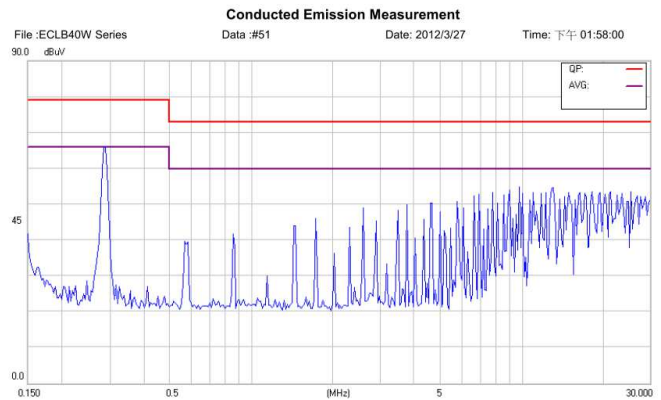

Figure 15 Conducted Class A ECLB40W-24S15

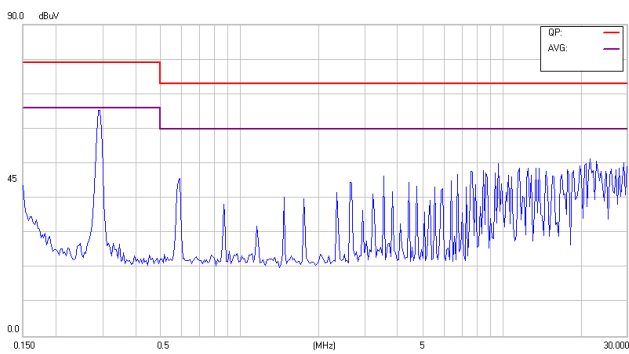

Figure 16 Conducted Class A of ECLB40W-24D12

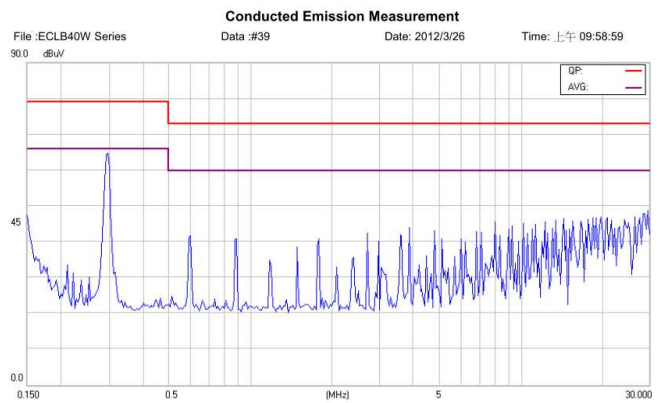

Figure 17 Conducted Class A of ECLB40W-24D15



# ECLB40W 33-40 Watt Isolated DC-DC Converters

## Application Note V12 November 2018

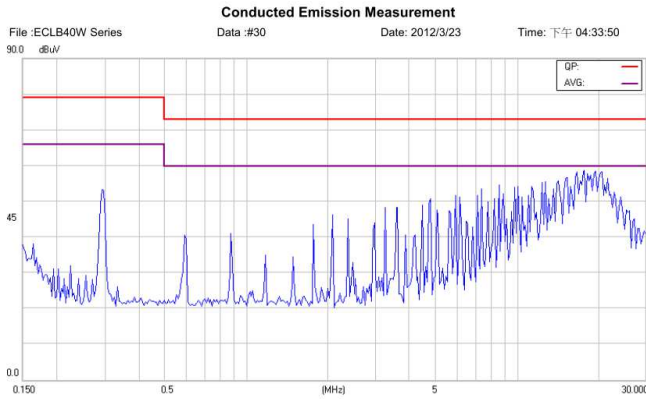

Figure 18 Conducted Class A of ECLB40W-48S33

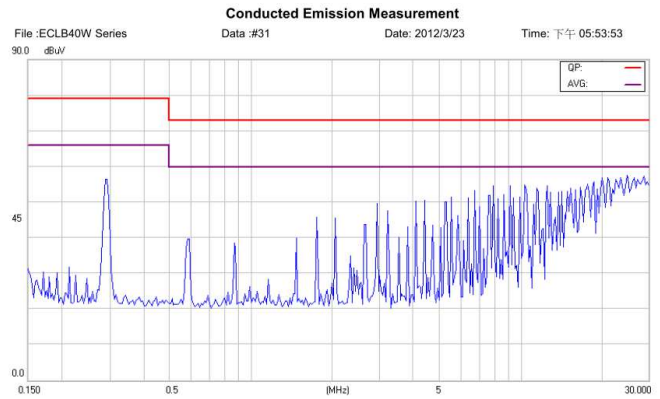

Figure 19 Conducted Class A of ECLB40W-48S05

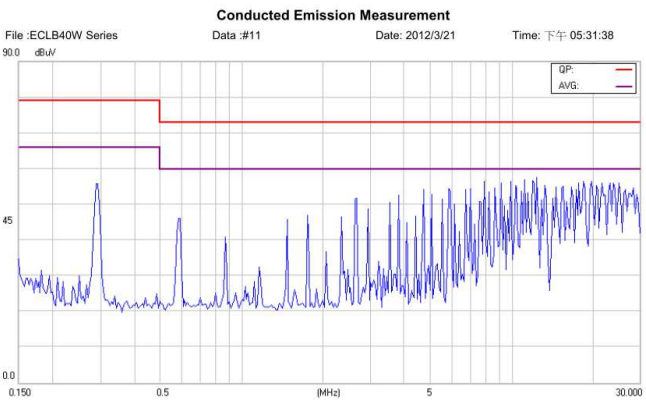

Figure 20 Conducted Class A of ECLB40W-48S12

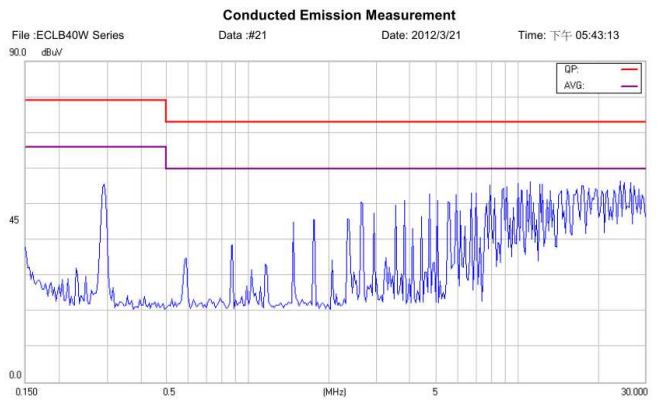

Figure 21 Conducted Class A of ECLB40W-48S15

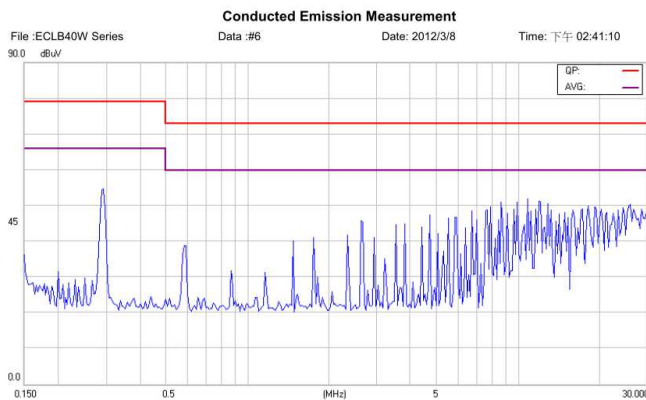

Figure 22 Conducted Class A of ECLB40W-48D12

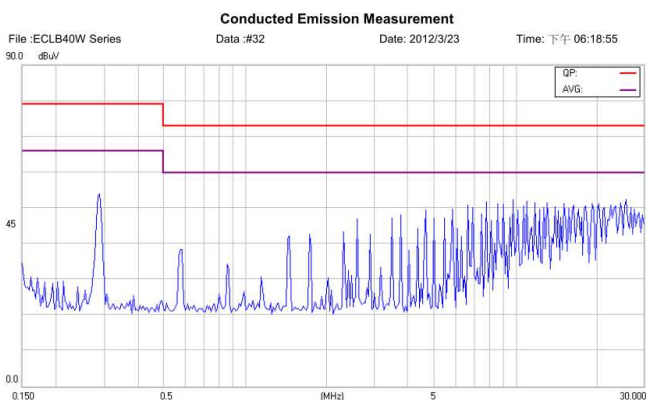

Figure 23 Conducted Class A of ECLB40W-48D15



# ECLB40W 33-40 Watt Isolated DC-DC Converters

## Application Note V12 November 2018

### 8. Part Number

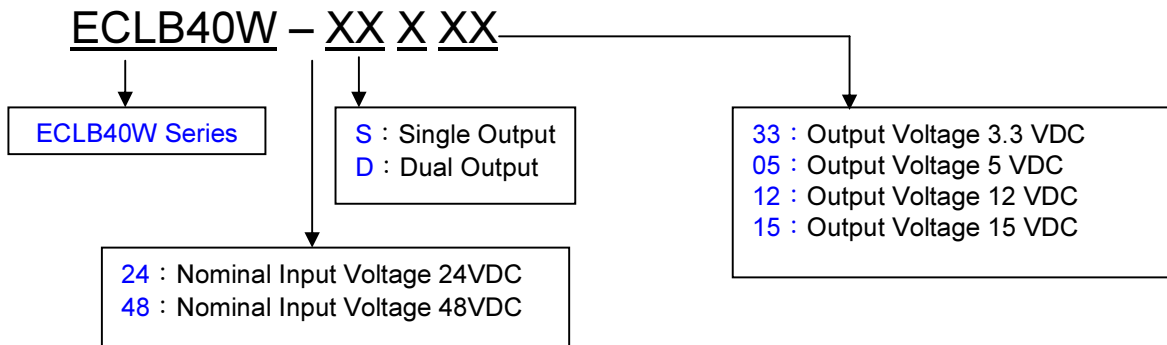

### 9. Mechanical Specifications

NOTE: Pin Size is 0.04±0.004 Inch (1.0±0.1 mm)DIA  
 All Dimensions in Inches[mm]  
 Tolerance Inches:x.xx=±0.02 ,x.xxx=±0.010  
 Millimeters:x.x=±0.5 , x.xx=±0.25

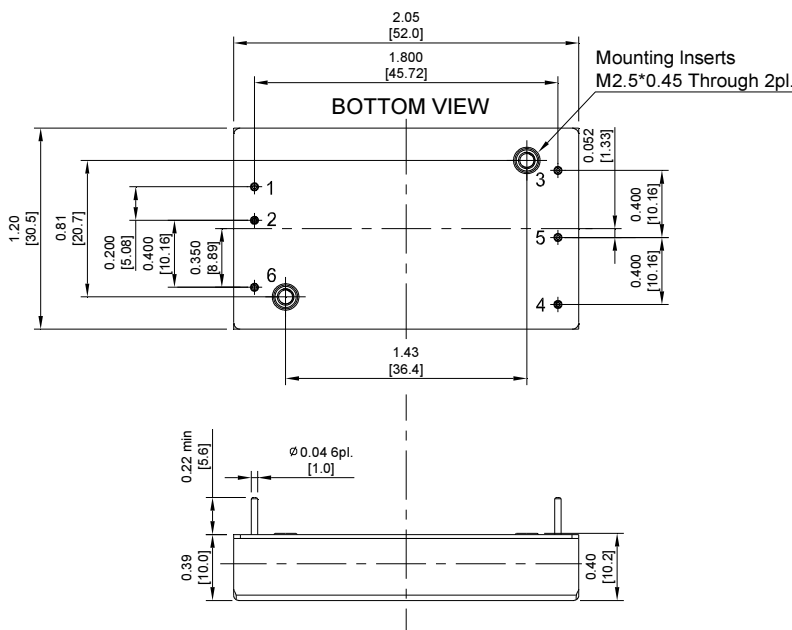

PIN CONNECTION		
PIN	Single Output	Dual Output
1	+V Input	+V Input
2	-V Input	-V Input
3	+V Output	+V Output
4	Trim	-V Output
5	-V Output	Common
6	Remote On/Off	

CINCON ELECTRONICS CO., LTD.		
<b>Headquarter Office:</b> 14F, No.306, Sec.4, Hsin Yi Rd., Taipei, Taiwan Tel: 886-2-27086210 Fax: 886-2-27029852 E-mail: sales@cincon.com.tw Web Site: http://www.cincon.com	<b>Factory:</b> No. 8-1, Fu Kong Rd., Fu Hsing Industrial Park Fu Hsing Hsiang, ChangHua Hsien, Taiwan Tel: 886-4-7690261 Fax: 886-4-7698031	<b>Cincon American Office:</b> 1655 Mesa Verde Ave, Ste 180, Ventura, CA 93003 Tel: 805-639-3350 Fax: 805-639-4101 E-mail: info@cincon.com