

PF100 Active power factor correction and harmonic attenuation module

85 – 265 Vin, 100 watts

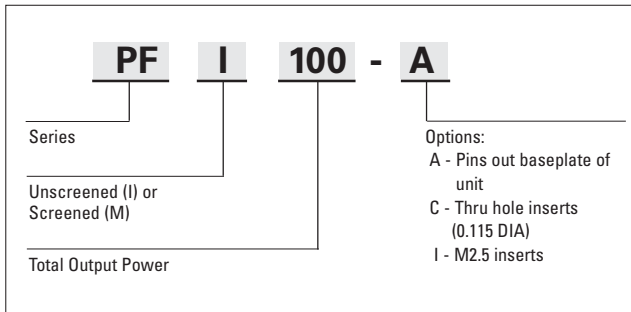

HOW TO ORDER



FEATURES

- Meets all Requirements of MIL - STD - 1399, section 300A
- Meets CE01 and CE101 of MIL - STD - 461 without external filter
- Meets all requirements of MIL - STD - 704E
- Meets all requirements of ABD0100.1.8.1
- Non-latching Over Temperature Protection
- Non-latching Output Overvoltage Protection
- Output short circuit protection, automatic recovery after short circuit removal
- Isolated Output DC Good TTL Signal (Open collector)
- Full 100 Watts of output power from 85 VAC to 265 VAC and up to 100°C baseplate temperature
- Utilizes non isolated boost topology
- Dual Nominal Voltage setting:
275V for 85 - 170 Vrms Input
380V from 180 - 264 Vrms Input
- Environmental Screening available

INPUT CHARACTERISTICS

	Min.	Typ.	Max.	Units
Input Voltage (Single Phase)	85		265	VAC
Input Frequency Range	45		800	Hz
Inrush Current				
@115 Vrms			3	A
@240 Vrms			5	A
Power factor at Full Load				
115V _{in} / 60 - 400Hz	0.98	0.99		
115V _{in} / 800Hz	0.94	0.96		
230V _{in} / 50Hz	0.97	0.99		
230V _{in} / 400Hz	0.92	0.93		
230V _{in} / 800Hz	0.79	0.80		
Efficiency at Full Load				
115V _{in} / 60Hz	92	93		%
115V _{in} / 400Hz	91	92		%
230V _{in} / 50Hz	92	93		%
230V _{in} / 400Hz	92	93		%
230V _{in} / 800Hz	92	93		%

OUTPUT CHARACTERISTICS

	Min.	Typ.	Max.	Units
Nominal No Load Voltage Setting	273 or 380		278 or 385	V
Output Power (Full Load)			100	W
Load Regulation (No Load - Full Load)			2.2	% V _{out}
Line Regulation (Low Line - High Line)			1	% V _{out}
Ripple P - P (60 Hz/115 VAC input)			3.5	% V _{out}
Overvoltage Protection (% of Output)	103	105	110	% V _{ou}
Transient Response: 25 - 75 - 25% or 50 -100 - 50% step load				
Overshoot / Undershoot		±6.3		% V _{out}
Recovery time (to 2% of V _{out})			200	mS
Temperature Drift		0.01	0.02	%/°C
Output (Holdup) Capacitance		Not Included		
	(specs are based on 100µF)			

All specifications are typical @+25°C with nominal input voltage under full output load conditions and holdup capacitance of 100 µF, unless otherwise noted. Specifications subject to change without notice.

PF100 Active power factor correction & harmonic attenuation module

TEMPERATURE CHARACTERISTICS

	Min.	Typ.	Max.	Units
Operating	-55		+100	° C
Storage - Ambient	-55		+105	° C
Over Temperature Shutdown		+105	+115	° C
Hysteresis		10		° C
Thermal Resistance Case- Ambient		7.14		° C/W

M- GRADE - ENVIRONMENTAL SCREENING

Stabilization Bake	+105°C for 24 hours similar to MIL -STD -883, M1008.2, Condition B
Temperature Cycling	10 cycles at -55°C to +125°C (transition period 5°C / minute) similar to MIL -STD -883, M1010, Condition B
Burn in	160 hours @ 85°C minimum
Final Testing	Full ATP

I- GRADE - ENVIRONMENTAL SCREENING

Burn in	16 hours @ 50°C minimum
Final Testing	Full ATP

ISOLATION CHARACTERISTICS

	Min.	Units
Isolation:		
Input/Output to Base	1500	VAC
Insulation resistance @ 500 VDC	100	MOhm

MECHANICAL CHARACTERISTICS

Weight (Max.)	5.5	oz.
	150	grams
Size	2.4 x 2.3 x 0.5	inch
	61 x 58.4 x 12.7	mm
Volume	2.76	inch ³
	45.7	cm ³
Material: Pin	Brass (Solder Plating)	
Case	Steel (28 Gauge CRS)	
Baseplate	Aluminum (6061-76)	
Finish: Case	Nickel Plating	
Baseplate	None	
Mounting: Standard	4-40 THD Inserts	
Option - I	Metric M2.5 - 0.45 Inserts	
Option - C	.115 DIA Thru Hole	

CASE DRAWINGS - PF100 STANDARD

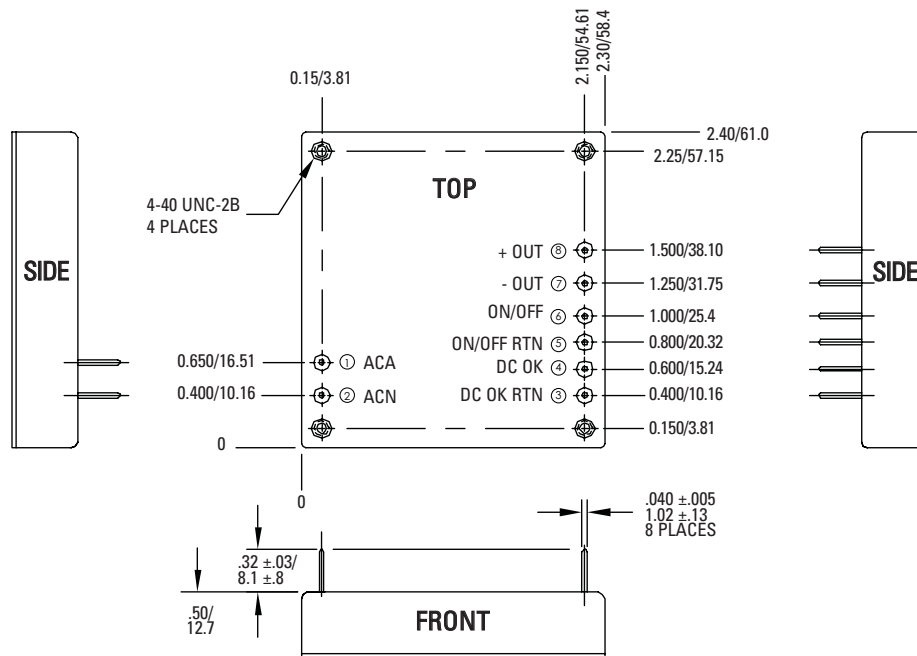

Tolerances: inches - x.xx = ±0.03 mm - x.x = ±0.8
 x.xxx = ±0.015 x.xx = ±0.40

All specifications are typical @+25°C with nominal input voltage under full output load conditions and holdup capacitance of 100 µF, unless otherwise noted. Specifications subject to change without notice.

CASE DRAWINGS - PF100 OPTION -A; PINS OUT BASEPLATE OF UNIT

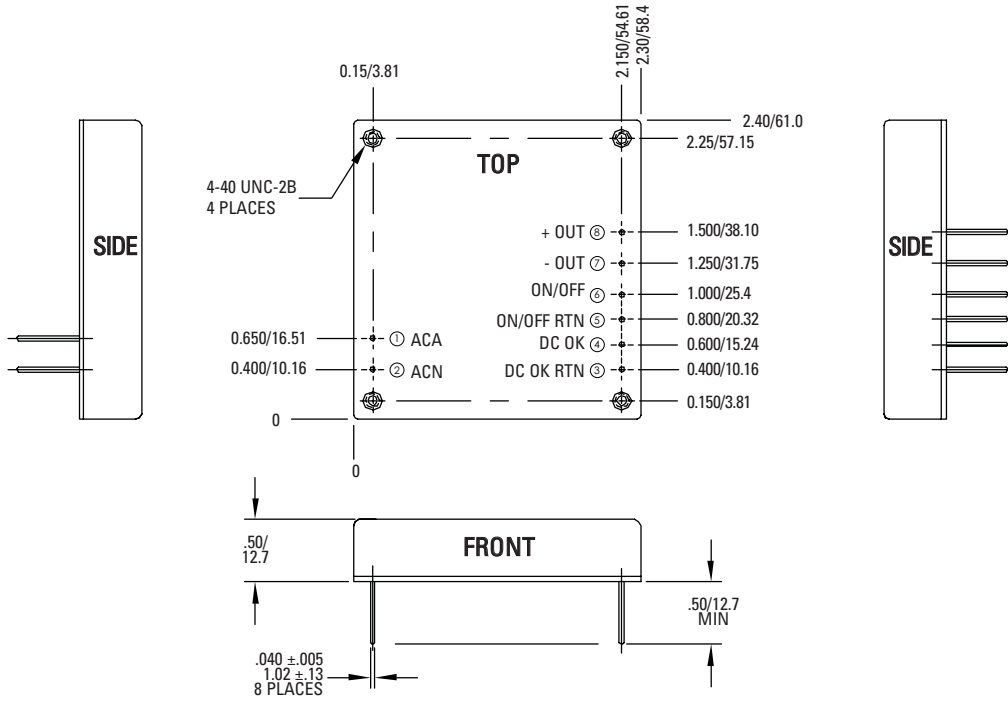

CASE DRAWINGS - PF100 OPTION -C; THRU HOLE INSERTS

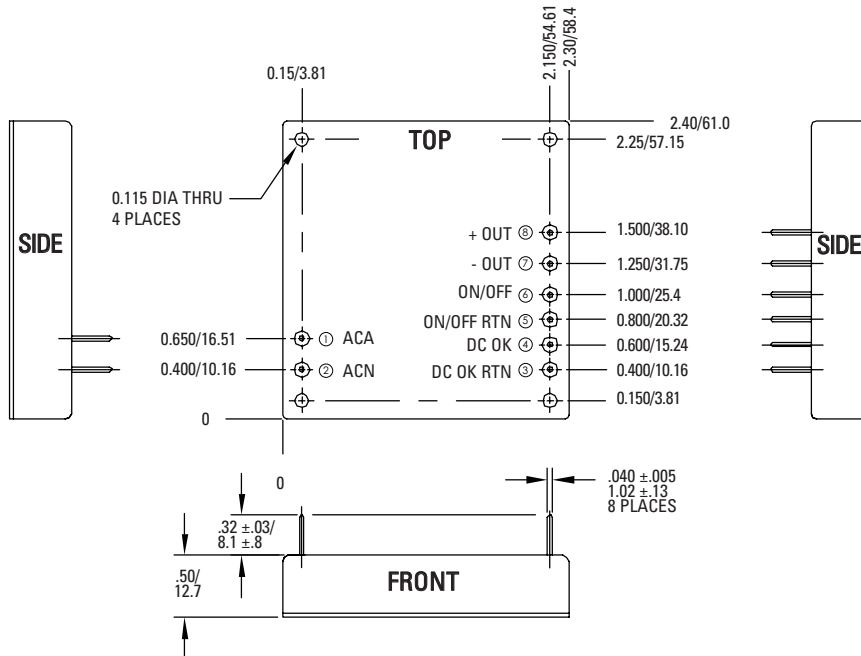

All specifications are typical @+25°C with nominal input voltage under full output load conditions and holdup capacitance of 100µF, unless otherwise noted. Specifications subject to change without notice.

Performance characteristics

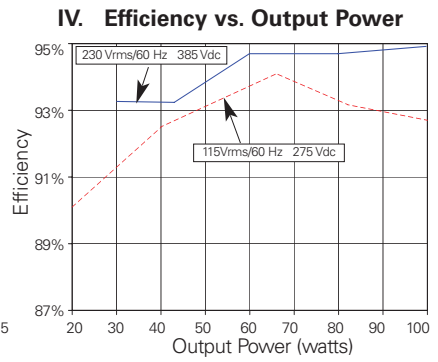
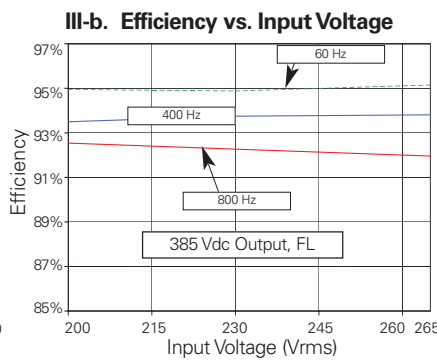
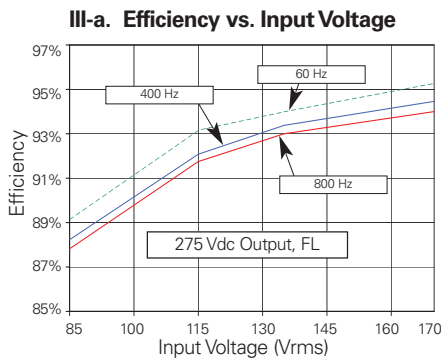
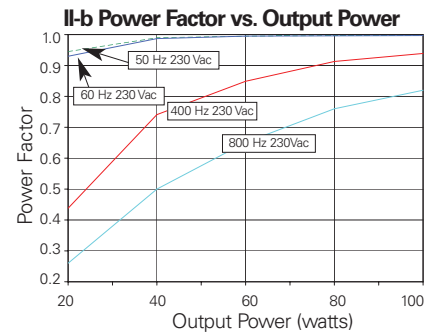
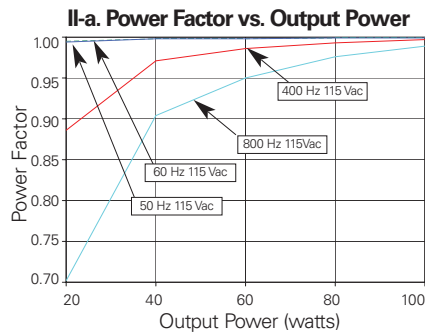
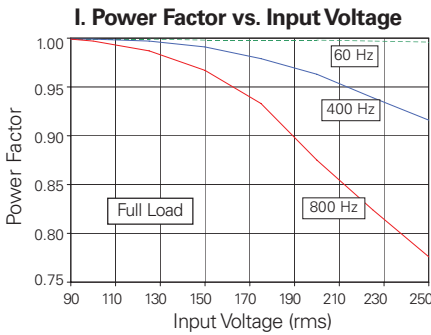

V-a. AC Input Voltage & Current

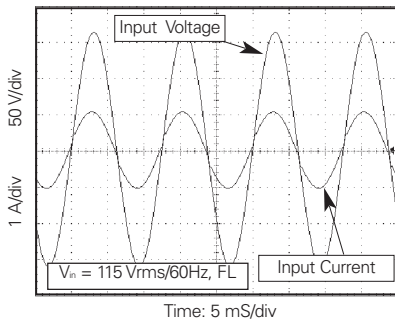

V-b. AC Input Voltage & Current

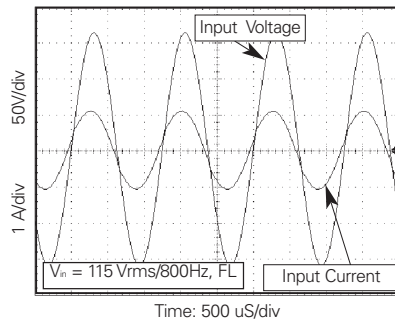

VI. Output Ripple

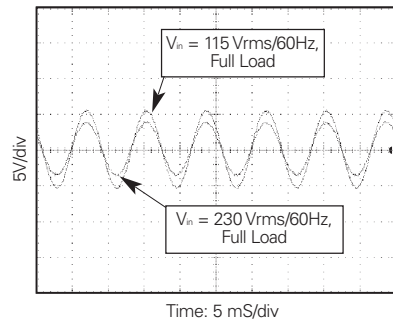

VII. Load Transient Response

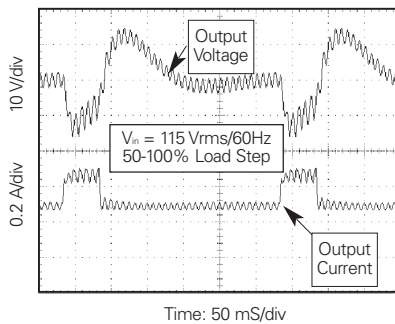

VIII. Line Transient

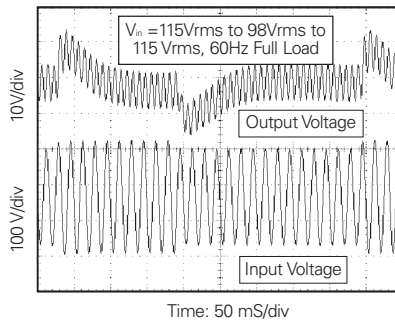

IX-a. Harmonic Distortion

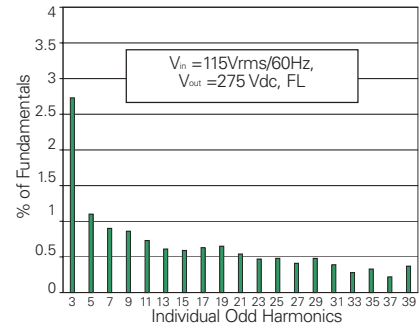

EMI filters

IX-b. Harmonic Distortion

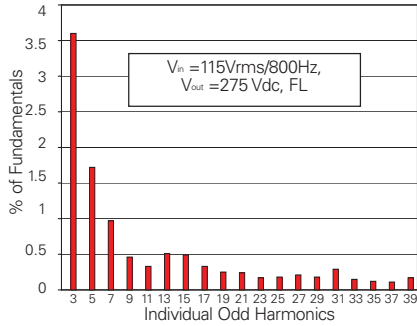

X-a. Inrush Current vs Output Voltage

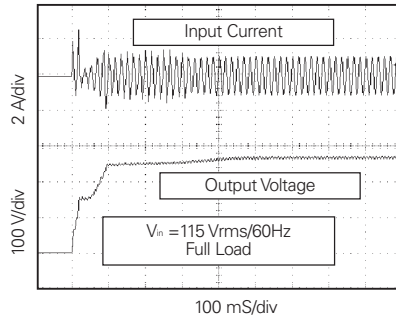

X-b. Inrush Current vs Output Voltage

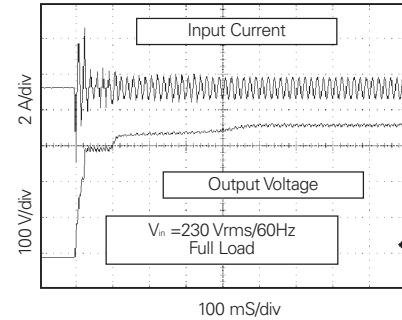

XI. DC Good, Turn-On

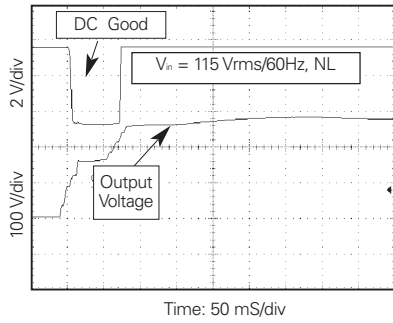

XII. DC Good, Turn-Off

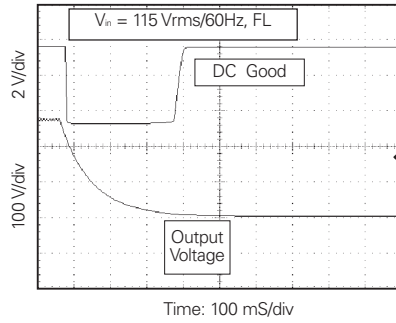

XIII-a. Input Line Dropout

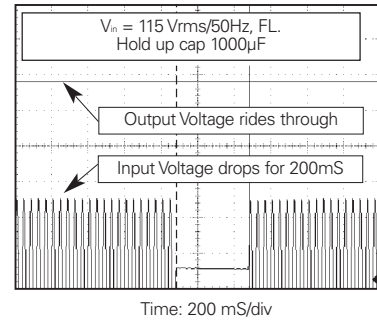

XIII-b. Input Line Dropout

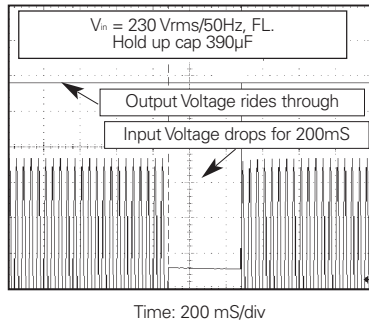

EMI Plots

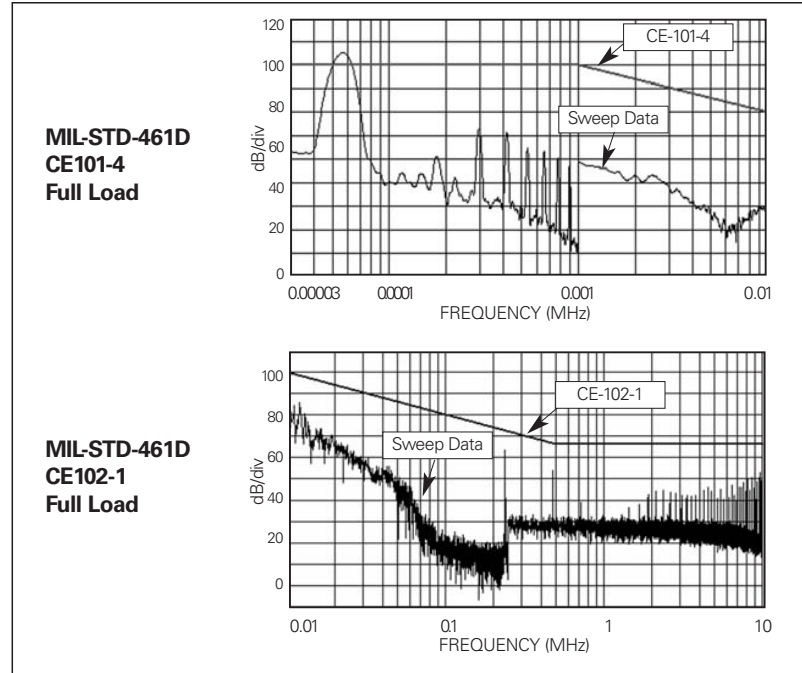

For additional information, call 310.542.8561
or e-mail: Orders-EP@eaton.com

Eaton
1000 Eaton Boulevard
Cleveland, OH 44122
United States
Eaton.com

© 2017 Eaton
All Rights Reserved
Printed in USA
May 2017

Eaton is a registered trademark.

All other trademarks are property
of their respective owners.

