

1800 series

Single, Dual, Triple Output DC/DC Converter



FEATURES

- 0.400 Inch Case Profile
- -55°C to +85°C Ambient Operation
- Wide Input Voltage Range
- Input Filter Meets Requirements of MIL-STD-461C, MIL-STD-704D and MIL-STD-1275A
- Meets MIL-STD-202 and MIL-STD-810 Test Conditions
- >600,000 Hours MTBF per MIL-HDBK-217F
- 6 sided Continuous Shielding

DESCRIPTIONS

The **1800 series** of 16W DC/DC converter modules combine innovative design techniques, conservative component selection and stringent test standards to achieve very high levels of reliability, performance and power density. Per MIL-HDBK-217F, that MTBF is >600,000 hours (+25°C Ground Benign) and greater than 125,000 hours for Airborne Inhabited. The **1800 series** has been designed specifically to meet the rigorous demands of avionics equipment. Eight models have wide 16 VDC to 36 VDC inputs, centered on 28 VDC. Single, dual or triple output combinations of 5, 12, 15, ± 5 , ± 12 and ± 15 VDC are provided. Standard features include 1000 VDC input/output isolation, output ripple and noise of less than 1% and continuous short circuit protection. Efficiency is as high as 80%. A remote ON/OFF control input and internal PI filter are standard.

Long field life is insured by extensive reliability screening at Martek Power. All **1800 series** units are designed to the requirements of MIL-STD-202 and MIL-STD-810. As part of the normal production processing, each unit is subjected to 72 hours of burn-in with power cycling and load switching. The **1800 series** converters have been qualified and meet MIL-STD-704D emergency power conditions for aircraft, and MIL-STD-461C and MIL-STD-1275A for EMI and transient protection. Compliance to the EMI standards of MIL-STD-461C (including CE01 and RE01) is achieved without the need for external filtering components.

Each **1800 model** is packaged in a very low profile 2.56 x 3.0 x 0.4 inch metal case. Six-sided continuous shielding insures each converter meets the requirements of VDE 0871 Class B for radiated emissions. Full operation is specified over the wide temperature range of -55°C to +85°C with no derating or heatsinking required. Cooling is by free-air convection.

Martek Power's **1800 series** has been designed to meet the military standards applicable to avionics applications. For specific information on test methods and/or test levels or our own reliability processing, please contact the factory. Some of the applicable military standards include:

MIL-STD-810E This standard establishes the methods of testing the effects of natural and induced environments on equipment used in military applications.

MIL-STD-461C This standard sets the design and documentation requirements for controlling the electromagnetic emission and susceptibility characteristics of electronic equipment.

MIL-STD-202E This standard outlines the test methods for determining a components' resistance to the effects of natural elements and conditions. Typically used on small components such as resistors, capacitors and transformers. Tests numbered 300 thru 399 cover electrical characteristics.

MIL-STD-1275A This standard describes the transient voltage characteristics and steady state limits for 28 VDC powered circuits used in military vehicle.

MIL-STD-704D This standard defines the conducted electrical power characteristics for aircraft systems at the interface between the power system and electronic equipment. It insures the compability of aircraft electric systems and ground support



OUTPUT CHARACTERISTICS

	Unit/Comments
Voltage & Current Ratings ²	See Model Selection Guide
Output Voltage Accuracy	
Single/Dual Output Models	±1%, Max.
Triple Output Models	±4%, Max.
Voltage Adjustment ³	±5%
Voltage Balance ⁴	
Dual Outputs	±2%, Max.
Triple Outputs (Aux. Outputs)	±4%, Max.
Ripple & Noise, 20 MHz BW	1% Pk-Pk of Vout
Line Regulation	
Single Output Models	±0.5%, Max.
Dual Output Models	±0.5%, Max.
Triple Output Models: Primary	±0.5%, Max.
Aux.	±1.0%, Max.
Load Regulation	
Single Output Models	±0.5%, Max.
Dual Output Models	±1.0%, Max.
Triple Output Models: Primary	±0.5%, Max.
Aux.	±1.0%, Max.
Min. Load	10% of Full Load
Temperature Coefficient @ FL	±0.02%/°C, Max.
Temperature Coefficient Balance	±1%
Transient Recovery Time ⁵	100 µSec Max. to 1% of Final value
Short Circuit Protection	All outputs, by input current limiting
Over Voltage Protection	See Model Selection Guide

SPECIFICATION NOTES

- ¹ = The max. input range of 16 to 50 VDC is specified for 250 mS (Per MIL-STD-704D).
- ² = Total output power should not exceed 16W. The load on any auxiliary output should not exceed 500 mA.
- ³ = Outputs are adjustable on single and dual output units only.
- ⁴ = Voltage balance is measured with balanced loads applied.
- ⁵ = Transient response is measured on the primary output for a 50% load change (50% load to full load).
- ⁶ = Efficiency is specified at nominal input line and full load.
- ⁷ = These converters have a thermal resistance of 2.1 °C/W (Internally dissipated). The internal thermal protection circuits are triggered if the case temperature exceeds 95°C. Maintaining the module case temp. below 95°C can be accomplished by mounting a low thermal resistance heat sink (with vertically orientated fins) to the case with a thermally conductive compound. This will significantly increase heat transfer from the module to the ambient. Forced convection cooling can also be used. The amount of cooling will depend upon the flow of air in linear feet per minute (LFM) over the module.

INPUT CHARACTERISTICS

	Unit/ Comments
Input Voltage, Nominal	28 VDC
Input Voltage range ¹	18 VDC to 36 VDC
Input Surge	Per Mil-STD-704D and MIL-STD-1275A
Input Filter	Dual input(π)Pi Network. Differential and common mode type. Meets the requirements of FCC 20780 Class B for computing devices. Meets requirements of MIL-STD-461C, CE01.
Reverse Polarity Input Current	12A, Max.
Short Circuit Current Limit	150% of Current Input
Overvoltage Shutdown	> 50 VDC
Undervoltage Shutdown	8 VDC
Transient Protection	600W @ 1 mSec
Remote On/Off control	
Supply On	5.5 VDC or Open Circuit
Supply Off	0 VDC to 0.8 VDC
Logic Input Reference	Negative (-) Input
Logic Compability	TTL Open Collector or CMOS Open Drain
Standby Current	32 mA

GENERAL CHARACTERISTICS

	Unit / Comment
Efficiency ⁶	See Model Selection Guide
Isolation Voltage Isolation	1000 VDC, Min; Primary to sec. for 1 min. per MIL-STD-202F, Method 301.
Isolation Resistance	100 MOhms per MIL-STD-202F, Method 302, Test condition B
Acceleration	Per MIL-STD-810E, Method 513.4, Prodedure II. Operation test (centrifuge) 12g's (Manned Aerospace Vehicles).
Shock	Per MIL-STD-810E, Method 516.4, Procedure I. Functional shock 40g's.
Vibration	Per MIL-STD-810E, Method 514.4, Prodedure I, Cat 6 (equipment installed in Helicopters)
Altitude	Per MIL-STD-810E, Method 500.3, Prodedure III. Rapid decompression, 40K ft.
Humidity	Per MIL-STD-810E, Method 507.3, Procedure I. Natural non-hazardous items, cycle 1,240 Hrs.
Switching Frequency	100 kHz, Min.

Martek Power reserves the right to change specifications without notice.



ENVIRONMENTAL SPECIFICATIONS

	Min	Typ	Max	Unit/Comments
Operating Temp. Range	-55		+85	°C; Ambient
Storage Temp. Range	-60		+125	°C; Ambient
Overtemperature ⁷	Protected by auto shutdown w/ an auto restart			
Cooling	Meets the requirement of VDE 0871 class B for radiated emissions. Also meets MIL-STD-461C RE01. (see "Shielding")			

PHYSICAL CHARACTERISTICS

	Unit/Comments
Case Size	2.56 X 3.0 X 0.40 inches (66 X 76.2 X 10.2 mm)
Case Material	Coated Copper
Weight	4 oz (113g)
Shielding	Six-sided, Continuous
Shield Connection	Pin 3 (- Input)
Reliability Specifications:	Ground, @+25°C Ambient -
MTBF; per MIL-HDBK-217F	616,846 Hrs. Ground Fixed, @ +25°C Ambient - 250,000 Hrs.

OUTLINE DRAWING

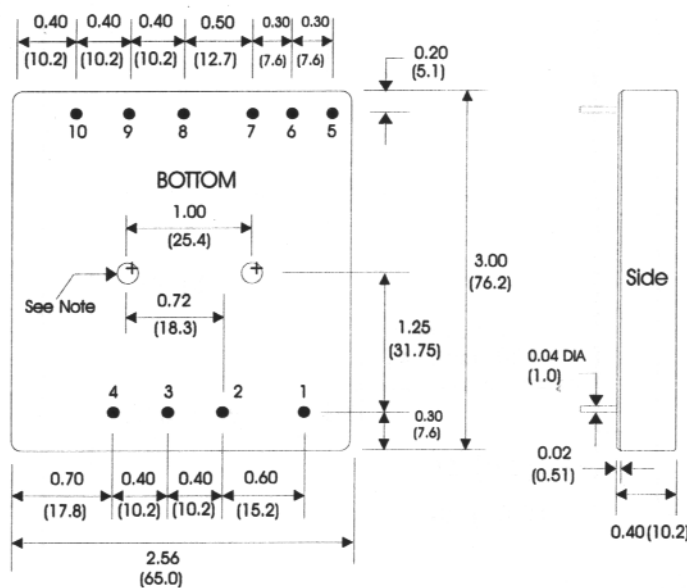

PIN OUT CHART; CASE A

Pin	Single	Dual	Triple
1	Remote On/Off	Remote On/Off	Remote On/Off
2	+ Input	+ Input	+ Input
3	- Input	- Input	- Input
4	Sync	Sync	Sync
5	+ Output Sense	+ Output	+ Output (Aux)
6	Trim	Common	Common (Aux)
7	- Output Sense	- Output	-Output (Aux)
8	+ Output	Output Trim	+ 5V Output
9	- Output	No Pin	-5V Output
10	No Pin	No Pin	Output Trim(5V)

Notes:

For proper operation of a single output unit without sensing or external trimming, connect + Output Sense (Pin 5) to + Output (Pin 8) and - Output Sense (Pin 7) to - Output (Pin 9)

All dimensions are typical in inches (mm)

Tolerance:

Inches	mm
X.XX = ±0.02	X.X = ±0.5
X.XXX = ±0.010	X.XX = ±0.25

Mounting inserts are 4-40x .10(2.5) Deep

All specifications are typical at nominal input, nominal load and 25° C unless otherwise specified.
External, low ESR, 10 microfarad (minimum) capacitor across output is recommended for operation.



How To ORDER

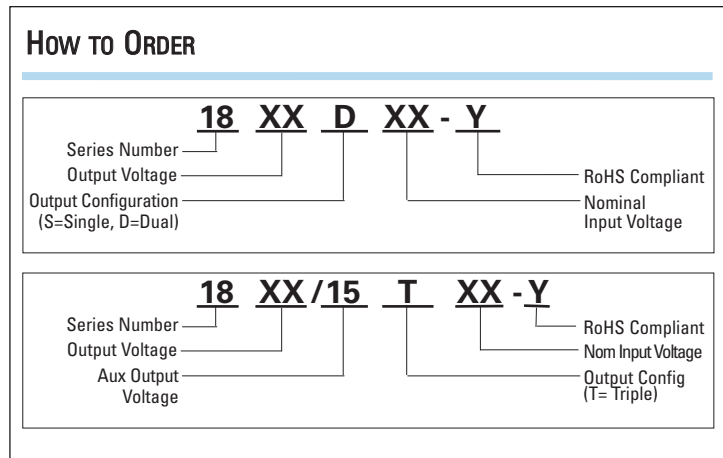

MODEL SELECTION CHART

Model	Nominal Input Voltage (VDC)	Input Voltage Range (VDC)	No Load Input Current (mA)	Full Load Input Current (mA)	Output Voltage (VDC)	Output Current (mA)	Output Over Voltage (VDC)	Efficiency @ FL (%)
1805S28	28	16 - 36	50	730	5	3200	6.8	78
1812S28	28	16 - 36	50	730	12	1330	15.0	78
1815S28	28	16 - 36	50	730	15	1067	18.0	78
1805D28	28	16 - 36	50	730	±5	±1600	±6.8	78
1812D28	28	16 - 36	50	730	±12	±670	±15.0	80
1815D28	28	16 - 36	50	730	±15	±530	±18.0	80
1805/12T28	28	16 - 36	50	730	5/±12	2000/±250	6.8/±15.0	78
1805/15T28	28	16 - 36	50	730	5/±15	2000/±200	6.8/±18.0	78