

2100 series

Single, Dual, Triple Output DC/DC Converter



DESCRIPTIONS

The 2100 series 20 watts high performance DC/DC converters are cost effective solution to the high reliability and performance requirements of power distribution systems in applications ranging from high speed data communications equipment to industrial robotic systems. The 2100 series operates over 2:1 input voltage ranges of 10 to 18, 18 to 36 or 36 to 72VDC; providing single, dual and triple output combinations of 5, 12, 15, ± 5 , ± 12 , ± 15 , 5/ ± 12 and 5/ ± 15 VDC. All models are packaged in compact, low profile 2" X 2" X 0.4" metal cases.

OUTPUT CHARACTERISTICS

	Min	Typ	Max	Unit/Comments
Output Voltage Accuracy				
Single & Dual Outputs		± 1.0		% ¹
Triple Outputs - Primary		± 1.0		% ¹
- Auxiliaries		± 7.0		% ¹
Output Voltage Trim Range		± 10		%
Voltage Balance:				
Dual Outputs		± 1.0		%; Equal Output Loads
Triple Outputs (Auxiliaries)		± 1.0		%; Equal Output Loads
Minimum Load		10%		Full Load
Line Regulation				
Single & Dual Outputs		± 0.5		% ²
Triple Outputs - Primary		± 0.5		% ²
- Auxiliaries		5.0		% ²
Load Regulation				
Single Outputs		± 0.3		% ³
Dual Outputs		± 1.0		% ³ ; Equal Loads
Triple Outputs - Primary		± 0.5		% ³
- Auxiliaries		± 5.0		% ³ ; Equal Loads
Ripple/Noise				
5V Outputs		100		mV; p-p, Nom.Line FL, 20Mhz B.W. using 1 μ f bypass capacitor
12V and 15V Outputs		1		% of Vout
Short Circuit Protection				Continuous, Automatic Recovery
Transient Recovery Time		200		μ S to within 1% error band for 50% step load change
Temperature Coefficient		± 0.01		% per °C



FEATURES

- 6 sided Continuous Shielding
- Synchronization and Output Trim
- 12.5W/In³ Power Density
- Efficiency to 87%
- UL 1950 Approved
- CSA 22.2-950 Approved
- VDE / EN 60950 Approved

INPUT CHARACTERISTICS

	Min	Typ	Max	Unit/Comments
Input Voltage Range				
12 VDC Input Models	10	12	18	VDC
24 VDC Input Models	18	24	36	VDC
48 VDC Input Models	36	48	72	VDC
Remote On / OFF Control				
Supply ON				5.5 VDC or Open Circuit
Supply OFF				0 VDC to 0.8 VDC
Logic Referenced to Negative Input				
Reverse Polarity Input Current			12	Amp
Input Filter				Internal Capacitor; External 10-20 μ F cap recommended across input pins

GENERAL CHARACTERISTICS

	Min	Typ	Max	Unit/Comments
Switching Frequency	100			kHz
Isolation Voltage	1400			VDC, 1 minute
Isolation Resistance	1000			Mohm, 500VDC
Isolation Capacitance		60		pF, 100kHz, 1Volt
MTBF (MIL-HBK-217F)	700			Thousand Hours, +25°C, Ground Benign

¹ = Output voltage at nominal line & FL

² = % Output voltage measured from min. input line to maximum

³ = Output voltage measured from FL to 10% Load

Martek Power reserves the right to change specifications without notice.



ENVIRONMENTAL SPECIFICATIONS

	Min	Typ	Max	Unit/Comments
Operating Temp. Range (Industrial)	-25		+71	°C; Ambient
Operating Temp. Range (Extended, "-X" suffix)	-55		+85	°C; Ambient
Storage Temp. Range	-55		+125	°C
Relative Humidity			95	% Humidity; non-condensing
Cooling				Free-Air Convection

PHYSICAL CHARACTERISTICS

	Unit/Comments
Case Size	2.0 X 2.0 X 0.4 inches (51.0 X 51.0 X 10.2 mm)
Case Material	Coated Metal with Non-Conductive Base
Shield Connection	
12V and 24V Input Models	Negative Input
48V Input Models	Positive Input
Flammability	UL94V-0
Weight	79 Grams

OUTLINE DRAWING

CASE A

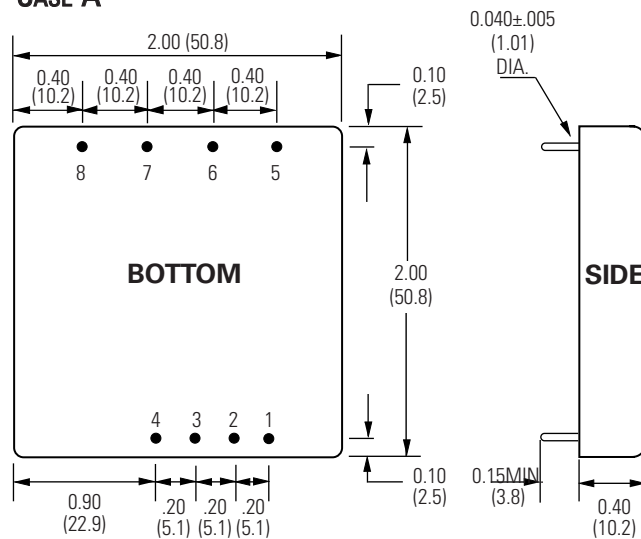

PIN OUT CHART; CASE A

Pin	Single	Dual	Triple
1	Remote On/Off	Remote On/Off	Remote On/Off
2	Sync	Sync	Sync
3	- Vin	- Vin	- Vin
4	+ Vin	+ Vin	+ Vin
5	Trim	Trim	- Vout (Aux)
6	- Vout	- Vout	Common
7	+ Vout	Common	+5V Vout
8	No Pin	+ Vout	+Vout (Aux)

CASE A1

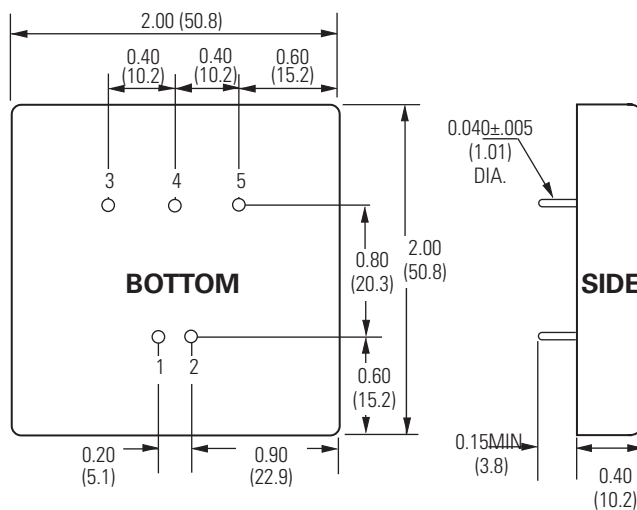

PIN OUT CHART; CASE A1

Pins	Single	Dual
1	+ Vin	+ Vin
2	- Vin	- Vin
3	+ Vout	+ Vout
4	Trim	Common
5	- Vout	- Vout

Notes:

- Unless otherwise specified dimensions are in inches (mm).

Tolerances	Inches	mm
	X.XX = ±0.02	X.X = ±0.5
	X.XXX = ±0.010	X.XX = ±0.25

All specifications are typical at nominal input, nominal load and 25° C unless otherwise specified.
 External, low ESR, 10 microfarad (minimum) capacitor across output is recommended for operation.



HOW TO ORDER

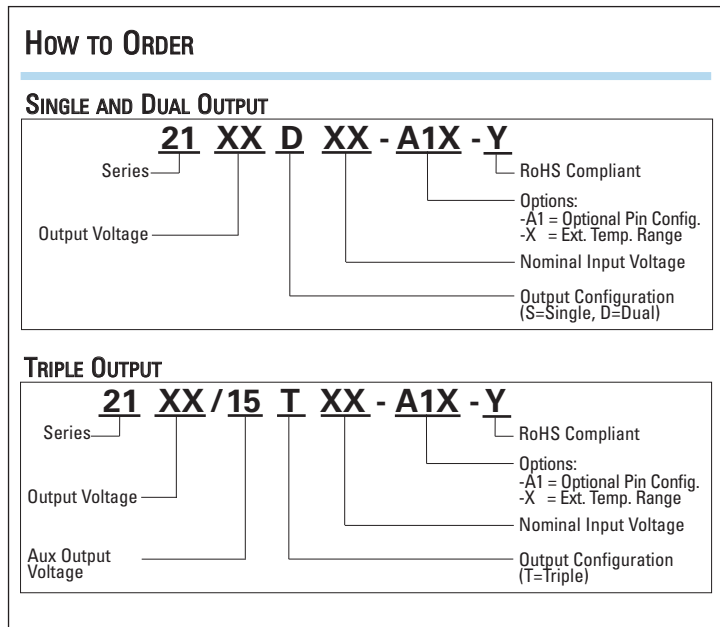

MODEL SELECTION CHART

Model	Nominal Input Voltage (VDC)	Output Voltage (VDC)	Full Load Output Current (mA)	No Load Input Current (mA)	Full Load Input Current (mA)	Output Over Voltage (VDC)	Fuse (A)	Efficiency (%)
2105S12	12	5	4000	45	2100	6.8	4.0	80
2112S12	12	12	1660	45	2100	15.0	4.0	80
2115S12	12	15	1330	45	2057	18.0	4.0	80
2105D12	12	±5	±2000	45	2000	±6.8	4.0	81
2112D12	12	±12	±830	45	2000	±15.0	4.0	83
2115D12	12	±15	±665	45	1500	±18.0	4.0	83
2105S24	24	5	4000	35	1000	6.8	2.0	83
2112S24	24	12	1660	35	990	15.0	2.0	84
2115S24	24	15	1330	35	990	18.0	2.0	84
2105D24	24	±5	±2000	35	1016	±6.8	2.0	82
2112D24	24	±12	±830	35	1000	±15.0	2.0	83
2115D24	24	±15	±665	35	1000	±18.0	2.0	83
2105S48	48	5	4000	32	490	6.8	1.5	85
2112S48	48	12	1660	32	500	15.0	1.5	83
2115S48	48	15	1330	32	500	18.0	1.5	83
2105D48	48	±5	±2000	32	502	±6.8	1.5	83
2112D48	48	±12	±830	32	482	±15.0	1.5	86
2115D48	48	±15	±665	32	478	±18.0	1.5	87
2105/12T12	12	5, ±12	2000, ±416	60	2081	6.8, ±15.0	4.0	80
2105/15T12	12	5, ±15	2000, ±333	60	2082	6.8, ±18.0	4.0	80
2105/12T24	24	5, ±12	2000, ±416	60	1015	6.8, ±15.0	2.0	82
2105/15T24	24	5, ±15	2000, ±333	60	1016	6.8, ±18.0	2.0	82
2105/12T48	48	5, ±12	2000, ±416	30	502	6.8, ±15.0	1.5	83
2105/15T48	48	5, ±15	2000, ±333	30	502	6.8, ±18.0	1.5	83



OUTPUT VOLTAGE ADJUSTMENT (2100 SERIES - SINGLE OUTPUT)

The converter's output voltage may be trimmed by up to ±10% of the nominal output voltage.

TRIM UP (Case A)

Trim output voltage up by connecting an external resistor between Pins 5 and 6. Use the following equation, reference Table 1 for variables A.

$$R_{adj-up} = \frac{A}{\Delta \%} - 24 \text{ (k}\Omega\text{)}$$

Example:

Trim both outputs 5% up for 12V Output units, where A = 1.98, Δ % = 0.05

$$R_{adj-up} = \frac{1.98}{0.05} - 24 \text{ k}\Omega = 15.6 \text{ k}\Omega$$

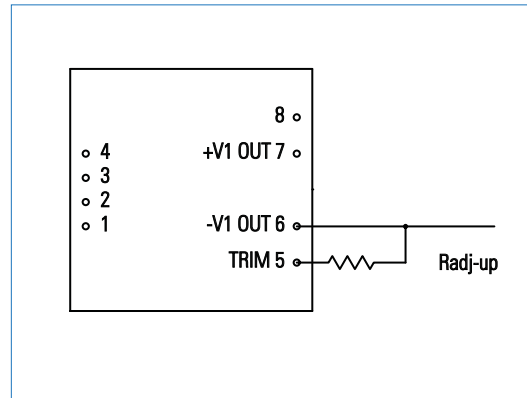

Table 1.

Output Voltage	A
5V	1.24
12V	1.98
15V	2.07

TRIM DOWN (Case A)

Trim output voltage down by connecting an external resistor between Pins 7 and 5. Use the following equation, reference Table 2 for variables C and D.

$$R_{adj-down} = \frac{C}{\Delta \%} - D \text{ (k}\Omega\text{)}$$

Example:

Trim 4% down for 5V Output units, where C = 1.24, D = 26.5, Δ % = 0.04

$$R_{adj-down} = \frac{1.24}{0.04} - 26.5 \text{ k}\Omega = 4.5 \text{ k}\Omega$$

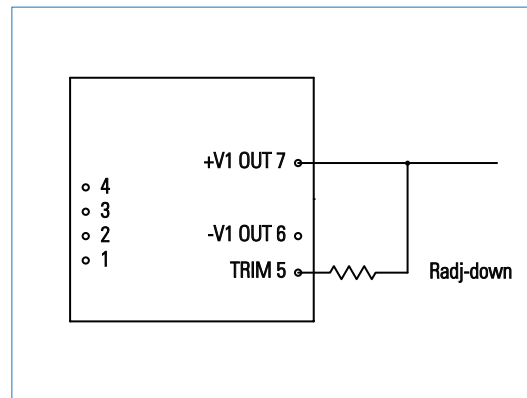

Table 2.

Output Voltage	C	D
5V	1.24	26.5
12V	7.57	33.5
15V	10.3	36.4



OUTPUT VOLTAGE ADJUSTMENT (2100 SERIES - DUAL OUTPUT)

The converter's output voltage may be trimmed by up to ±10% of the nominal output voltage.

TRIM UP (Case A)

Trim output voltage up by connecting an external resistor between Pins 5 and 8. Use the following equation, reference Table 1 for variables A.

$$\text{Radj-up} = \frac{A}{\Delta \%} - 24 \text{ (k}\Omega\text{)}$$

Example:

Trim both outputs 5% up for 12V Output units, where A = 1.98, Δ % = 0.05

$$\text{Radj-up} = \frac{2.23}{0.05} - 24 \text{ k}\Omega = 20.6 \text{ k}\Omega$$

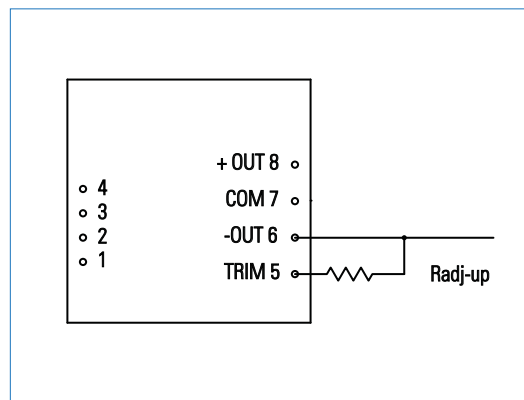

Table 1.

Output Voltage	A
5V	1.87
12V	2.23
15V	2.28

TRIM DOWN (Case A)

Trim output voltage down by connecting an external resistor between Pins 5 and 8. Use the following equation, reference Table 2 for variables C and D.

$$\text{Radj-down} = \frac{C}{\Delta \%} - D \text{ (k}\Omega\text{)}$$

Example:

Trim 5% down for 5V Output units, where C = 5.63, D = 31.5, Δ % = 0.05

$$\text{Radj-down} = \frac{5.63}{0.05} - 31.5 \text{ k}\Omega = 81.1 \text{ k}\Omega$$

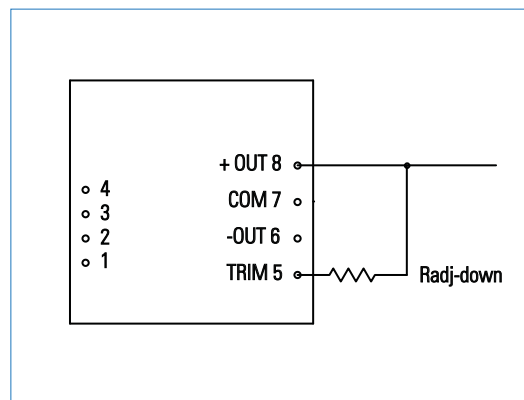

Table 2.

Output Voltage	C	D
5V	5.63	31.5
12V	19.3	45.5
15V	25.1	51.4



DERATING CURVES

MODEL 2100 - 20W, 5VDC

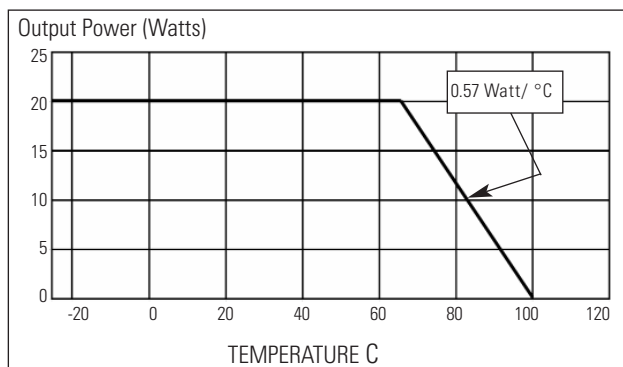

MODEL 2100 - All other models

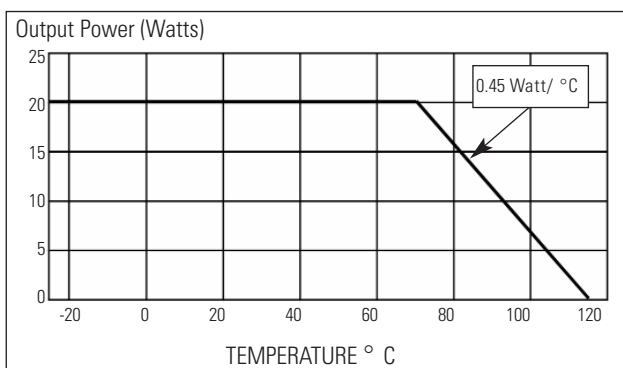

Notes:

1. The derating curves shown for the 2100 series represents ambient operating conditions. They assume that good thermal design practices are being used, including sufficient space in the vicinity of the converter for good air circulation. There are certain alternate techniques that can be utilized when the ambient temperature reaches the upper limit of a particular model:

- a. Using a heat sink.
- b. Mounting the converter on a metal plate which acts as a heat sink.
- c. Cooling by forced air.

Any of the above methods (or a combination of heat sinking and forced air) will increase the operating range of the converter up to 85°C maximum ambient temperature. However the baseplate (case) temperature must not exceed 115°C for more than one minute under any conditions.

2. External Synchronizing - All models in the 2100 series (packaged in the standard "A" case) can be synchronized to an external clock by driving the SYNC pin (pin 2) directly with open collector-open drain (1 TTL load). The driving signal frequency must be 220kHz, +/- 5% (20% low, 80% high duty cycle).

3. Although all models feature internal short circuit protection, it is recommended that their inputs be protected externally with a fuse. The fuse used must be a Slow-Blow type. Recommended rates are shown in the far right column of the model selection guide.