

HM Series

300 - 900 Watts Output Power

FRONT END RECTIFIERS

Each HM is sized to fit the input power requirements of the SM series DC/DC converters taking into account the converter loss. The table below describes this power rating relationship.

For example, one HM4 can provide enough input power for 300 watts of output. Unlike other front-end rectifiers NO external capacitance is required. All the necessary hold up capacitance is internal to the module. An AC power good signal is also provided for system monitoring.

HM4	400 watts input	1 DC/DC Converter	300 watts output
HM8	800 watts input	2 DC/DC Converters	600 watts output
HM12	1200 watts input	3 DC/DC Converters	900 watts output

MECHANICAL CHARACTERISTICS

		Max.	Units
Weight	HM4	2.5	Lbs.
		1.15	Kg.
	HM8	3.7	Lbs.
		1.7	Kg.
	HM12	5	Lbs.
		2.1	Kg.
Case Material	Aluminum Alloy		
Finish	Black Anodized		
Mounting	6, 10-32 inserts UNF-2B		
Hookup	Via Terminal Blocks		

THERMAL CHARACTERISTICS

	Min.	Typ.	Max.	Units
Operating Temperature Range	-40		+100	° C
Storage Temperature Range	-40		+105	° C
Power Dissipation (Full Load)				
HM4		20		W
HM8		25		W
HM12		30		W

Last update: Nov 8, 2010

Specifications subject to change without prior notice.



OUTPUT CHARACTERISTICS

		Min.	Typ.	Max.	Units
Output Current	HM4			1.75	A
	HM8			3.6	A
	HM12			5.6	A
Output Power	HM4			400	W
	HM8			800	W
	HM12			1200	W
Output Ripple		2		12	Vp-p
Output Voltage Range*		215		400	V
Output Voltage at Full Load		220		375	V
AC Leakage Current				5	mA
AC Power Good Voltage at 0 mA			4.8		V
AC Power Good Current at 4 Vo			0.8		mA
Isolation	Non-isolated intended for use with isolated DC/DC converters				

*5% Load Minimum

SAMPLE OUTPUT CONFIGURATIONS

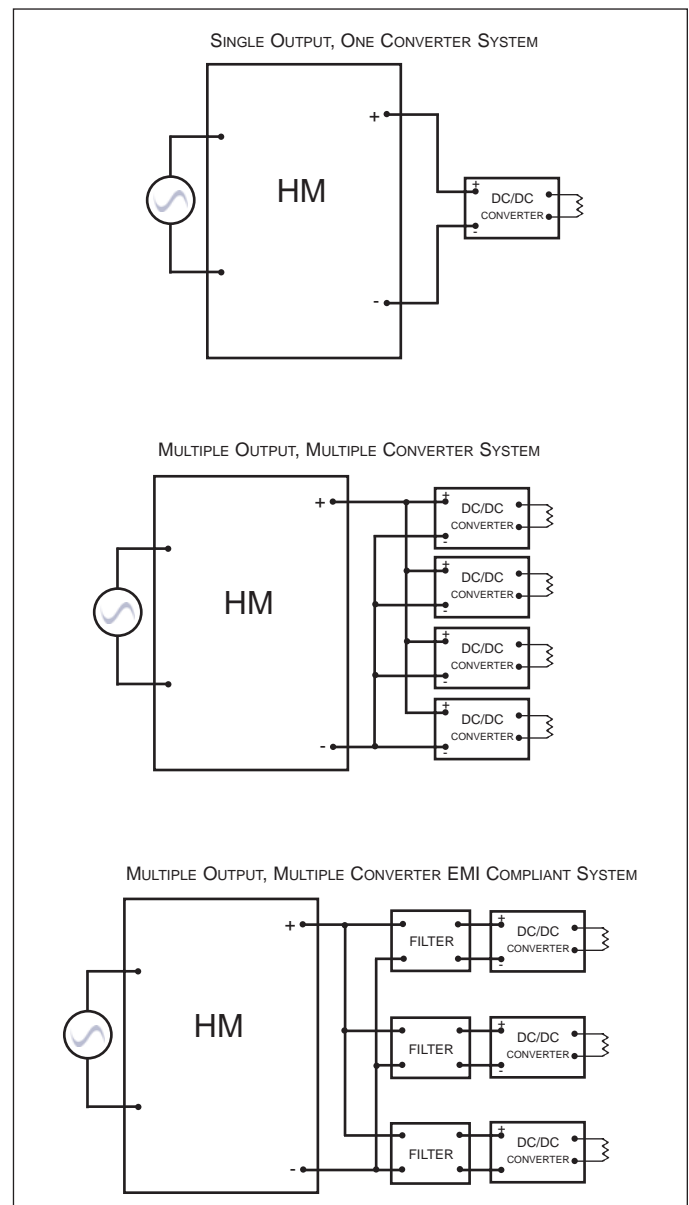



INPUT CHARACTERISTICS

1 1 5 V A C , 1 P H A S E

	Min.	Typ.	Max.	Units
Input Voltage Range	90	115	130	VAC
Inrush Current		110		A
Power Factor at 60 Hz FL		0.79		
Power Factor at 400 Hz FL		0.78		
Hold Up Time (Nominal Line to 200 Vdc at Full Load)		80		mS
Hold Up Time (Nominal Line to 200 Vdc at Half Load)		180		mS
Efficiency		95		%
Peak Input Current at Full Load	HM4	17		A
	HM8	20		A
	HM12	35		A
Transient	Per MIL-STD-704, 180 VAC for 0.1 seconds (DC/DC converters must also be compliant)			



HM4

2 2 0 V A C , 1 P H A S E

	Min.	Typ.	Max.	Units
Input Voltage Range	180	230	260	VAC
Inrush Current		110		A
Power Factor at 60 Hz FL		0.82		
Power Factor at 400 Hz FL		0.58		
Hold Up Time (Nominal Line to 200 Vdc at Full Load)		80		mS
Hold Up Time (Nominal Line to 200 Vdc at Half Load)		180		mS
Efficiency		95		%
Peak Input Current at Full Load	HM4	9		A
	HM8	19		A
	HM12	24		A



HM8

1 1 5 V A C , 3 P H A S E W Y E

	Min.	Typ.	Max.	Units
Input Voltage Range	90	115	130	VAC
Inrush Current		125		A
Power Factor at 60 Hz FL		0.73		
Power Factor at 400 Hz FL		0.73		
Hold Up Time (Nominal Line to 200 Vdc at Full Load)		80		mS
Hold Up Time (Nominal Line to 200 Vdc at Half Load)		200		mS
Efficiency		95		%
Peak Input Current at Full Load	HM4	9		A
	HM8	14		A
	HM12	19		A

2 2 0 V A C , 3 P H A S E D E L T A

	Min.	Typ.	Max.	Units
Input Voltage Range	180	230	260	VAC
Inrush Current		130		A
Power Factor at 60 Hz FL		0.73		
Power Factor at 400 Hz FL		0.73		
Hold Up Time (Nominal Line to 200 Vdc at Full Load)		80		mS
Hold Up Time (Nominal Line to 200 Vdc at Half Load)		200		mS
Efficiency		95		%
Peak Input Current at Full Load	HM4	6		A
	HM8	8		A
	HM12	12		A



HM12



INPUT CONNECTIONS

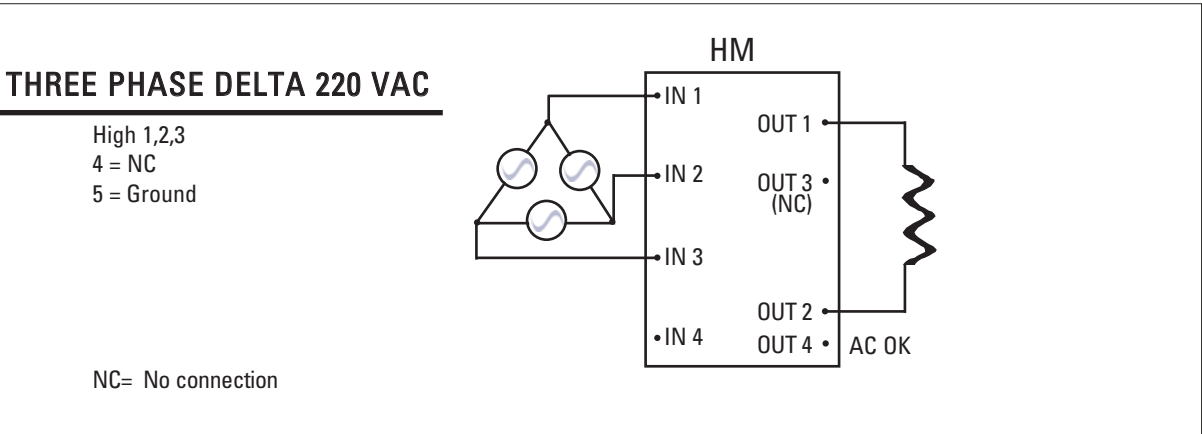
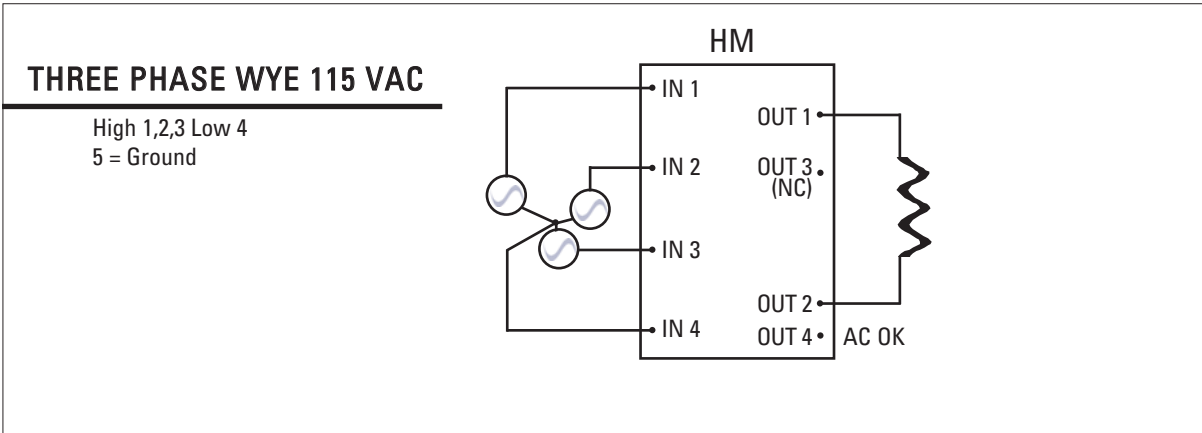
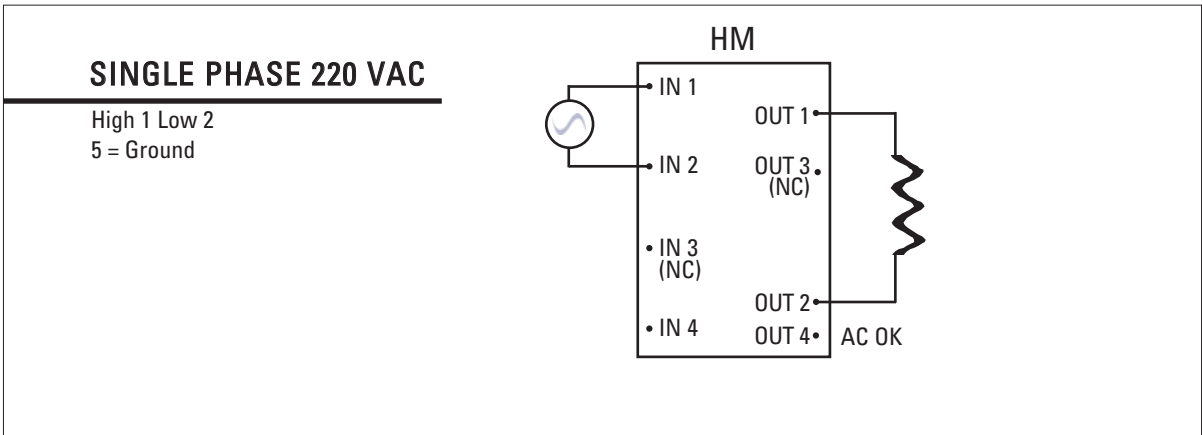
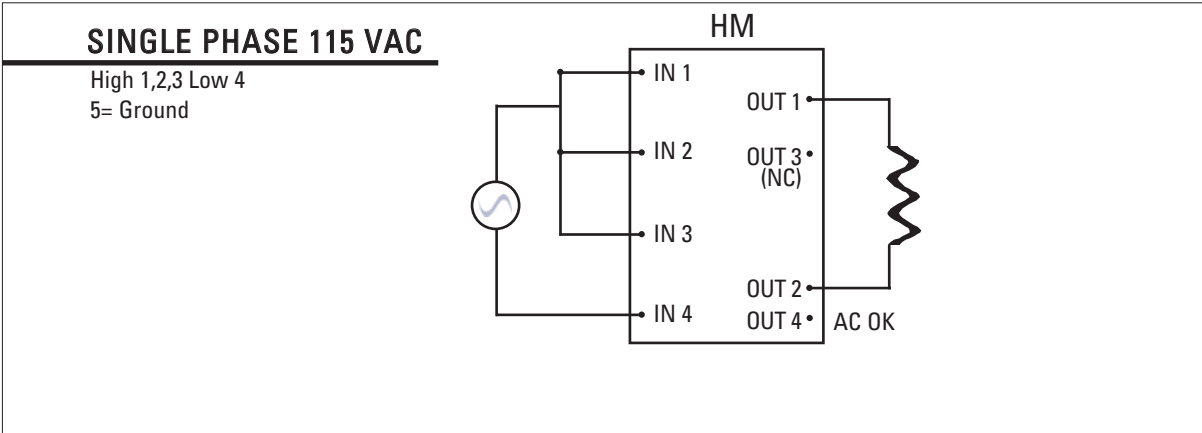



HM CASE DRAWINGS

