



LNB series

Single Output DC/DC Converter



DESCRIPTIONS

The LNB series are 10 watts low-profile dc-dc converters that operate over input voltage ranges of 4.5 - 7 VDC, 8 - 16 VDC and 18 - 36 VDC, and provide precisely regulated output voltages of 3.3V, 5V, 12V and 15V.

The -30°C to +71°C operating temperature range makes the LNB series ideal for data communication equipments, mobile battery driven equipment, distributed power systems, telecommunication equipment, mixed analog / digital subsystems, process/machine control equipment, computer peripheral systems and industrial robot systems.

OUTPUT CHARACTERISTICS

	Min	Typ	Max	Unit/Comments
Output Voltage Set Point		±1		% Output voltage at nominal line & FL
Line Regulation	-0.1		+0.1	Vo measured from min. input line to max.
Load Regulation	-0.1		+0.1	% Output voltage measured from FL to no load
Temperature Coefficient			0.01	% per degree C
Ripple/Noise			10	mV p-p measured at 10 MHz bandwidth with external 5 µf low ESR capacitor
Output Voltage and Current				Refer to model selection chart
Transient Response Deviation		2	4	% deviation of Vout voltage for step load 20-80% & 50-100% for 500µS
Short Circuit Protection				Indefinite, Automatic Recovery, Hickup.
Overvoltage Protection		125		% Hickup. See model selection chart
Turn-on Time			10	mS
Logic Turn-on			8	mS

FEATURES

- 6 sided Continuous Shielding
- Up to 85% Efficiency
- Output Overvoltage Protection
- 1500 VDC Input/Output Isolation
- Industry Standard 1.0" X 2.0" X 0.4" Package
- Short Circuit Protection
- Synchronization

INPUT CHARACTERISTICS

	Min	Typ	Max	Units/Comments
Input Voltage				
5 VDC Input Models	4.5		7	VDC
12 VDC Input Models	8		16	VDC
24 VDC Input Models	18		36	VDC
OverVoltage Shut Down				
5 VDC Input Models			9	VDC
12 VDC Input Models			19	VDC
24 VDC Input Models			39	VDC

GENERAL CHARACTERISTICS

	Min	Typ	Max	Unit/Comments
Clock Frequency		800		kHz
Switching Frequency		400		kHz
Isolation Voltage	1500			VDC, 1 minute
Isolation Resistance	50			Mohm, 50VDC
MTBF (MIL-HBK-217F)	0.6			Million Hours, +25°C, Ground Benign
Isolation Capacitance		1000		pF, 100kHz, 1Volt
Remote On/Off				
On		2	5	VDC; Referenced to input return
Off		-0.6	0.5	VDC; Referenced to input return
Synchronization			10	% above clock frequency



ENVIRONMENTAL SPECIFICATIONS

	Min	Typ	Max	Unit/Comments
Operating Temp. Range	-30		+71	°C; Ambient
Storage Temp. Range	-40		+100	°C; Case
Relative Humidity	0		95	% Humidity; non-condensing
Cooling				Free-Air Convection

PHYSICAL CHARACTERISTICS

	Unit/Comments
Case Size	1.0 X 2.0 X 0.4 inches (25.5 X 51.0 X 10.2 mm)
Case Material	Coated Metal with Non-Conductive Base
Shield Connection	Negative Input, Pin 2
Flammability	UL94V-0
Weight	40 Grams

OUTLINE DRAWING

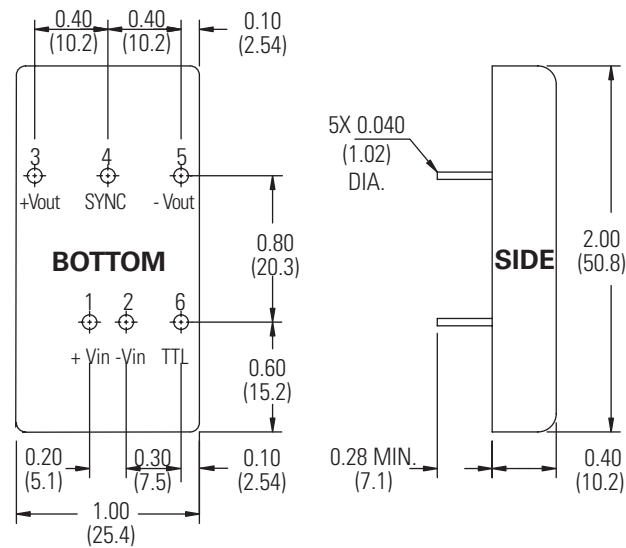

PIN OUT CHART

Pins	Single
1	+ Vin
2	- Vin
3	+Vout
4	SYNC
5	- Vout
6	TTL

Notes:

- Unless otherwise specified dimensions are in inches (mm).
Tolerances: X.XX = ±0.02 (±0.5)
X.XXX = ±0.010 (±0.25)
- Pin DIA. Tolerance: X.XXX = ±0.002 (±0.05)
- Sync. pin (Pin #4) is positive with respect to -Vin (Pin #2)

All specifications are typical at nominal input, nominal load and 25° C unless otherwise specified.
External, low ESR, 10 microfarad (typical) capacitor across output is recommended for operation.



How To ORDER

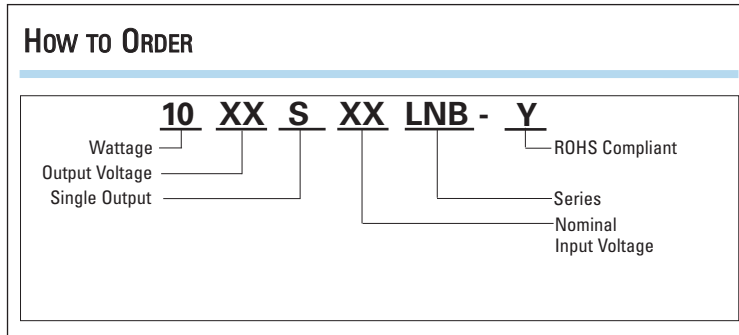

MODEL SELECTION CHART

Model	Nominal Input Voltage (VDC)	Output Voltage (VDC)	Full Load Output Current (A)	No Load Input Current (mA)	Full Load Input Current (mA)	Input (AC) Ripple Current (mA)	Fuse (Slow Blow) (A)	OVP Typical (VDC)	Efficiency @ FL (%)
1003S5LNB	5	3.3	3	65	2.64	30	3	3.9	75
1005S5LNB	5	5	2	40	2.4	30	3	6.2	83
1012S5LNB	5	12	0.83	40	2.35	30	3	15	85
1015S5LNB	5	15	0.67	40	2.38	30	3	18	84
1003S12LNB	12	3.3	3	40	1.05	30	2	3.9	79
1005S12LNB	12	5	2	30	1	30	2	6.2	83
1012S12LNB	12	12	0.83	30	0.98	30	2	15	85
1015S12LNB	12	15	0.67	30	0.98	30	2	18	85
1003S24LNB	24	3.3	3	30	0.52	30	1	3.9	79
1005S24LNB	24	5	2	20	0.5	30	1	6.2	83
1012S24LNB	24	12	0.86	20	0.49	30	1	15	85
1015S24LNB	24	15	0.67	20	0.49	30	1	18	85



DERATING CURVES

MODEL LNB series

