

# MW75S single-output AC/DC power supply

## Power factor corrected 90 – 265V<sub>in</sub>, 2 – 28V<sub>out</sub>, 75 watts

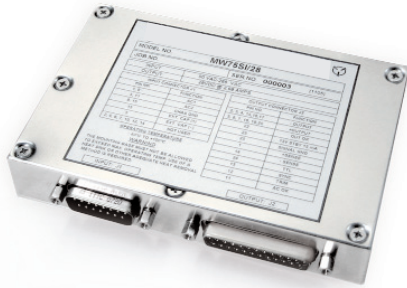

### HOW TO ORDER

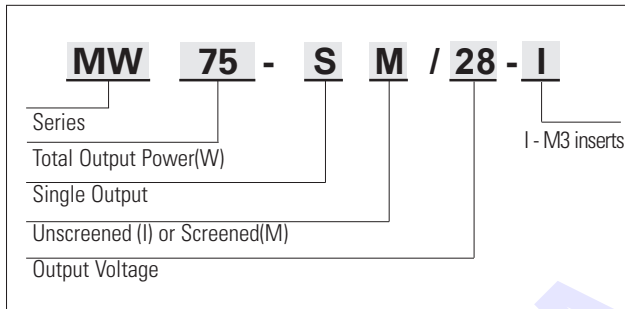

### INPUT CHARACTERISTICS

	Min.	Typ.	Max.	Units
Input Voltage (Single Phase)	90		265	Vac
Input Frequency Range	47		440	Hz
Input Voltage DC	120		380	Vdc
Inrush Current				
@115 Vrms			4	A
@240 Vrms			6	A
Power factor @75W Output Power				
115V <sub>in</sub> / 60Hz	0.98	0.99		
115V <sub>in</sub> / 400Hz	0.94	0.95		
230V <sub>in</sub> / 50Hz	0.95	0.97		
Efficiency at Full Load				
28V <sub>out</sub> , 115V <sub>in</sub> / 60Hz		78		%
28V <sub>out</sub> , 115V <sub>in</sub> / 400Hz		76		%
28V <sub>out</sub> , 230V <sub>in</sub> / 50Hz		80		%
5V <sub>out</sub> , 115V <sub>in</sub> / 60Hz		75		%
5V <sub>out</sub> , 115V <sub>in</sub> / 400Hz		74		%
5V <sub>out</sub> , 230V <sub>in</sub> / 50Hz		78		%
No Load Input Current		0.17		Arms
No Load Input Power		20		W
Input Power, Output Disabled		9		W
Input Undervoltage Shutdown			89	Vac
Input Undervoltage Hysteresis		6		Vac

### FEATURES

- Meets Harmonic Requirements of MIL - STD - 1399
- Meets CE101 and CE102 of MIL - STD - 461 (No external filter required)
- Meets MIL standards: MIL - STD - 704E and MIL - STD - 810
- Non-latching Over Temperature Protection
- Latching Output Overvoltage Protection
- Isolated Input AC Good TTL Signal
- Isolated Output DC Good TTL Signal
- Isolated 13 VDC Standby Output
- Fully rated 75 Watts of output power from 90 VAC to 265 VAC and up to 100°C baseplate temperature
- Utilizes non isolated boost topology followed by isolated DC-DC converter
- Environmental Screening available
- Fixed frequency PFC and DC-DC converters synchronized at 240/480 kHz or to a 500 - 550 kHz external clock
- 380 VDC PFC High Voltage Bus is accessible at the input connector for external holdup capacitor

### SELECTION CHART

Nominal Output Voltage (Volts)	Output Current (Amps)	Model Number (Unscreened)	Model Number (Screened)
2	37.5	MW75SI/2	MW75SM/2
3.3	27.8	MW75SI/3.3	MW75SM/3.3
5	15.0	MW75SI/5	MW75SM/5
12	6.25	MW75SI/12	MW75SM/12
15	5.0	MW75SI/15	MW75SM/15
24	3.13	MW75SI/24	MW75SM/24
28	2.68	MW75SI/28	MW75SM/28

All specifications are typical @+25°C with nominal input voltage under full output load conditions, unless otherwise noted. Specifications subject to change without notice.



Powering Business Worldwide

For additional information, call 310.542.8561  
or e-mail: Orders-EP@eaton.com

www.eaton.com/powerconversion

## PFC HIGH VOLTAGE BUS CHARACTERISTICS

	Min.	Typ.	Max.	Units
Nominal / Voltage	375	385	390	Vdc
Internal Holdup Capacitance		50		μF
External Holdup Capacitance (customer supplied)	0		120	μF
Min. Output Holdup Voltage		190	200	Vdc
Output Holdup Time	20	30		mS

## CONTROLS INTERFACE CHARACTERISTICS

Referenced to floating Signal Ground

	Min.	Typ.	Max.	Units
TTL Logic Disable Current		135	150	μA
TTL Logic Disable Voltage	0		0.8	V
Sync Input Voltage	4.5		5.1	Vp-p
Sync Input Frequency	500		550	kHz
Sync Input Duty (High)	15		55	%
Sync Output Voltage		4	5	Vp-p
Status "OK"	4.4		5	V
Status "Bad" @ 2mA	0		0.8	Vdc
AC OK Threshold	88	90	95	Vac
AC "Bad" Response Time		8	10	mS
Output OK Threshold	±5	±7	±9	%Vout
Turn-on Overshoot			150 <sup>1</sup>	mV
Standby 13V	12		15	V
Standby 13V Load	0		15	mA

<sup>1</sup> 150mV or 3% Vout, whichever is greater.

## TEMPERATURE CHARACTERISTICS

	Min.	Typ.	Max.	Units
Operating <sup>1</sup>	-40		+100	°C
Storage - Ambient	-55		+125	°C
Over Temperature Shutdown <sup>2</sup>		+106	+115	°C

<sup>1</sup> Start-up guaranteed to -55°C

<sup>2</sup> Measured at baseplate (center line of output connector x center line of baseplate)

## OUTPUT CHARACTERISTICS

	Min.	Typ.	Max.	Units	
Set Point Accuracy			50 <sup>1</sup>	mV	
Load Regulation			25/0.5 <sup>2</sup>	mV/%	
Line Regulation		5/0.1	20/0.2 <sup>3</sup>	mV/%	
Ripple P-P (10 MHz)		60	100/1 <sup>4</sup>	mV/%	
Overvoltage Protection					
2 - 5 Vout		125/0.7 <sup>5</sup>		%Vout	
12 - 28 Vout		115		%Vout	
Transient Response Time - Overshoot					
20 - 80% Load (@Nom.Line)		200/100	500/250 <sup>6</sup>	μS/mV	
115 - 180Vac per MIL-STD-704A			500/250 <sup>6</sup>	μS/mV	
102 - 124Vac per MIL-STD-704A			500/250 <sup>6</sup>	μS/mV	
92 - 138Vac per MIL-STD-1399			500/250 <sup>6</sup>	μS/mV	
163 - 281Vac, 50 Hz			500/250 <sup>6</sup>	μS/mV	
240 - 350Vdc per MIL-STD-704E			500/250 <sup>6</sup>	μS/mV	
50 - 100% Load (@Nom.Line)		200/100	500/250 <sup>6</sup>	μS/mV	
Temperature Drift		0.02	0.05	%/°C	
Long Term Drift		0.02	0.05	%/1Khrs	
Current Limit		110	120	135	%Iout
Short Circuit Current	25	50	75	%Iout	
Load Capacitance			200 <sup>7</sup>	μF	
Remote Sense Compensation			0.5/10 <sup>8</sup>	Vdc/%	
Trim Range	90		110	%Vout	
Turn On Time		260	300	mS	
Logic Turn On Time		8	10	mS	

<sup>1</sup> or 1% maximum, whichever is greater

<sup>2</sup> whichever is greater from No Load to Full Load with line constant

<sup>3</sup> whichever is greater from Low Line to High Line at Full Load

<sup>4</sup> whichever is greater measured at 10 MHz Bandwidth

<sup>5</sup> or 0.7V maximum, whichever is greater

<sup>6</sup> or 5% maximum, whichever is greater

<sup>7</sup> or 3X Co, whichever is greater

<sup>8</sup> lesser of 10% of Vout or 0.5V

## ISOLATION CHARACTERISTICS

	Min.	Units
Isolation		
Input to Case	1000	Vdc
Input to Output	1000	Vdc
Input to Signal Ground	1000	Vdc
Output to Case	250	Vdc
Signal Ground to Output to Case	250	Vdc
Insulation Resistance @ 50Vdc	50	Mohm

All specifications are typical @+25°C with nominal input voltage under full output load conditions, unless otherwise noted. Specifications subject to change without notice.

### M-GRADE - ENVIRONMENTAL SCREENING

Stabilization Bake	+105°C for 24 hours similar to MIL-STD-883, M1008.2, Condition B
Temperature Cycling	10 cycles at -55°C to +105°C (transition period 5°C/ min) similar to MIL-STD-883, M1010, Condition B
Burn in	150 Hours at 85°C min.
Final Testing	Full ATP
MTBF @ 50°C, GB	144,830 Hours

### I-GRADE - ENVIRONMENTAL SCREENING

Burn in	16 Hours @ 50°C min.
Final Testing	Full ATP
MTBF @ 50°C, GB	71,330

### MECHANICAL CHARACTERISTICS

Weight	14.11 (max)	oz.
	400 (max)	grams
Size	3.44 x 5.16 x 0.85	inch
	87.4 x 131.1 x 21.6	mm
Volume	15.09	inch <sup>3</sup>
	247.50	cm <sup>3</sup>
Material		
Case	Steel	
Baseplate	Aluminum Alloy	
Finish		
Case	Nickel Plated	
Baseplate	Aluminum baseplate	
Mounting		
Standard	4-40 THD Threaded	
Option - I	Metrics M3X 0.5	

### CASE DRAWING

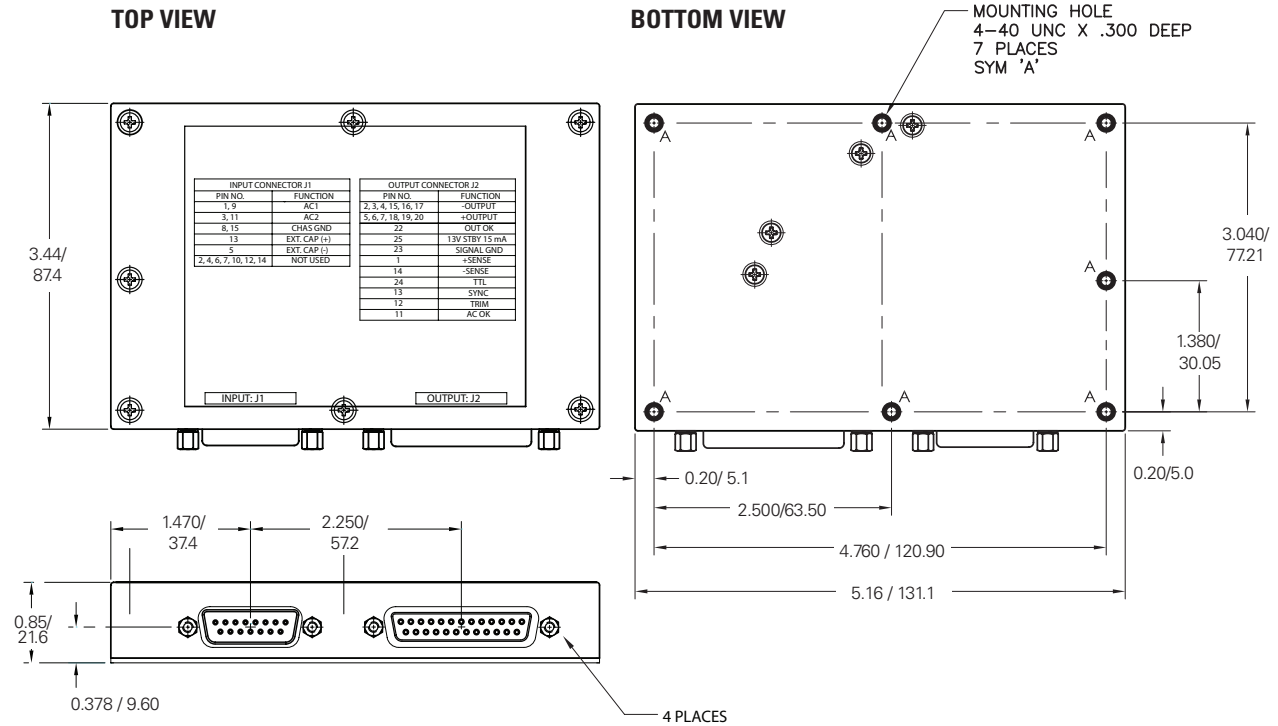

Tolerances: inches - x.xx = ±0.03 mm - x.x = ±0.8  
 x.xxx = ±0.015 x.xx = ±0.40

All specifications are typical @+25°C with nominal input voltage under full output load conditions, unless otherwise noted. Specifications subject to change without notice.

# PERFORMANCE CHARACTERISTICS

**1. Power Factor vs. Input Voltage**

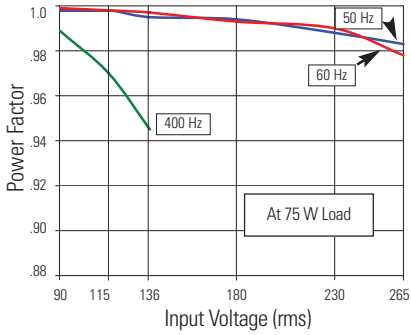

**2. Power Factor vs. Output Power**

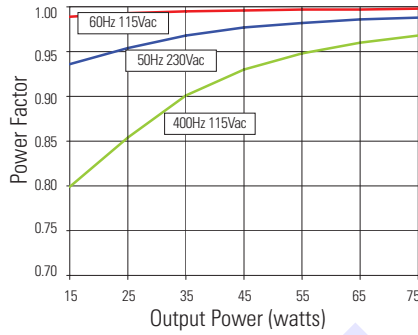

**3. Efficiency vs. Input Voltage**

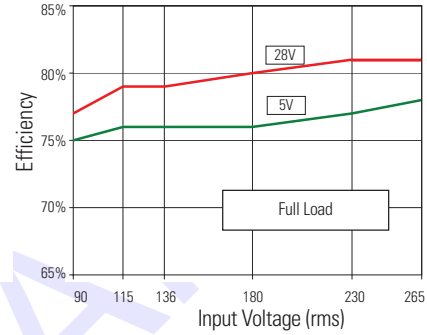

**4. Efficiency vs. Output Power**

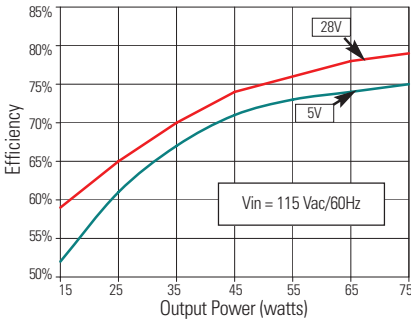

**5. AC Input Voltage & Current**

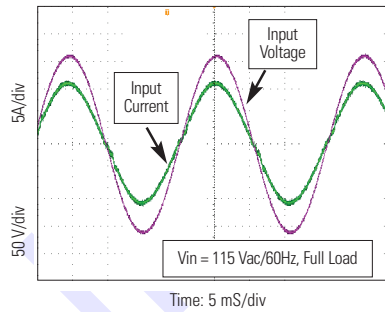

**6. Output Ripple (5Vout)**

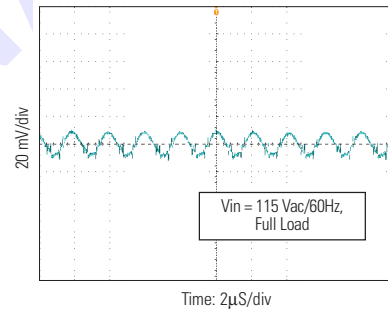

**7. Load Transient Response (5Vout)**

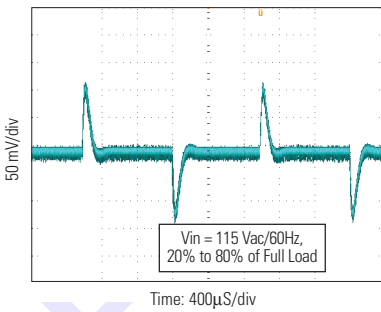

**8. Line Transient (60 Hz), no response at output**

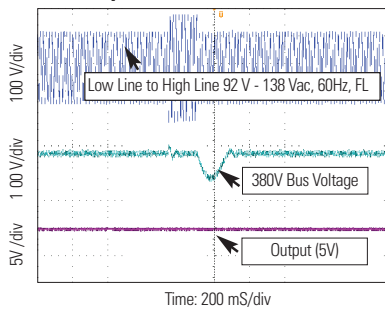

**9. Line Transient (400 Hz), no response at output**

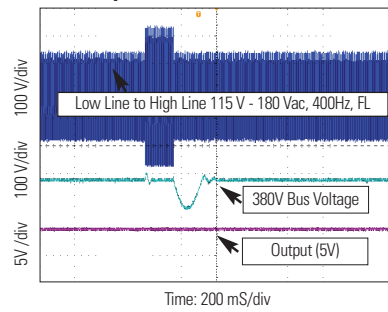

**10. Line Transient (50 Hz), no response at output**

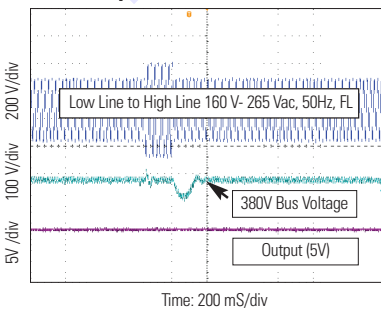

**11. Inrush Current vs. Intermediate Bus**

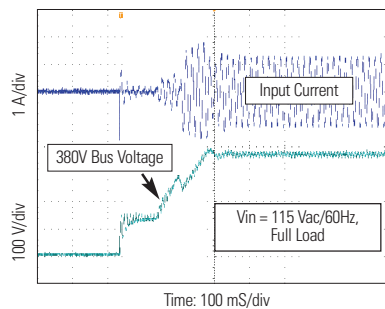

**12. Turn-on Input Voltage & Input Current vs. Output Voltage**

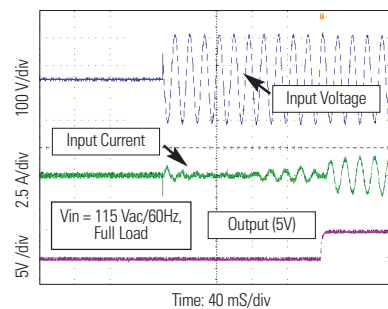

## PERFORMANCE CHARACTERISTICS

**13. Turn-on Input Voltage & Input Current vs. Output Voltage**

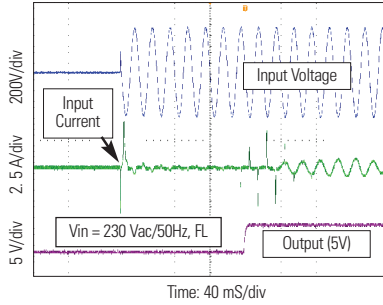

**14. TTL Turn-On**

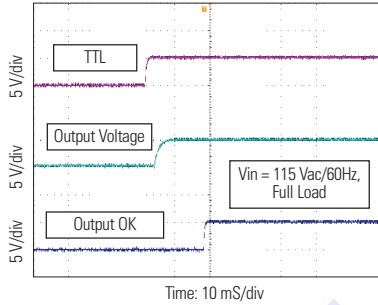

**15. TTL Turn-Off**

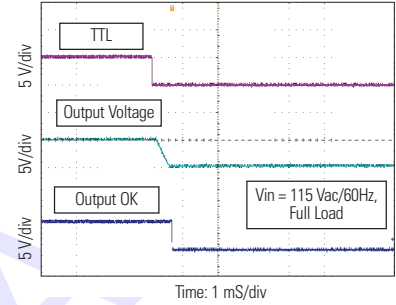

**16. Input Voltage Turn-Off vs. Output Voltage**

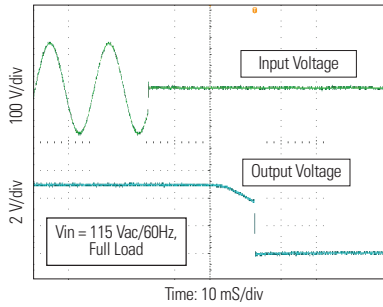

**17. Input Voltage Turn-Off vs. AC OK**

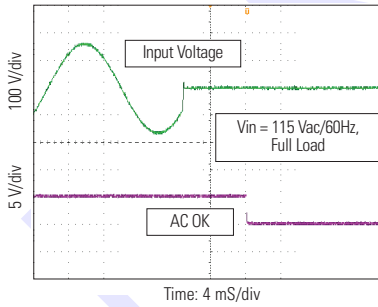

**18. Input Voltage Turn-On vs. AC OK**

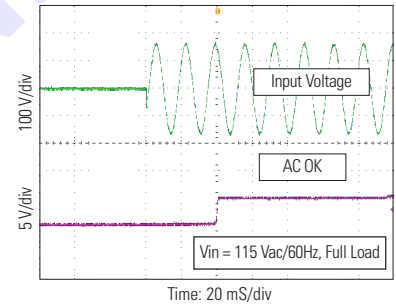

**19. Free-running Sync Output**

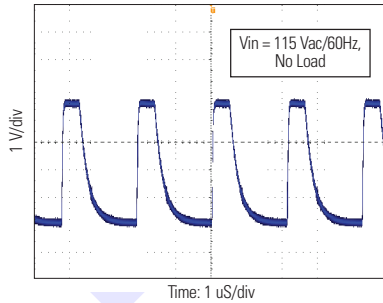

**20. Output Converter Voltage Loop Gain & Phase (5Vout)**

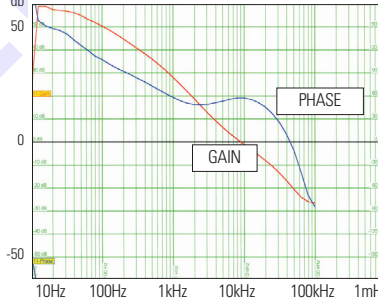

**21. Output Converter Voltage Loop Gain & Phase (28Vout)**

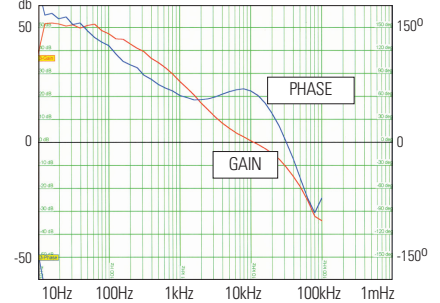

**22. MIL-STD-461D CE101-4**

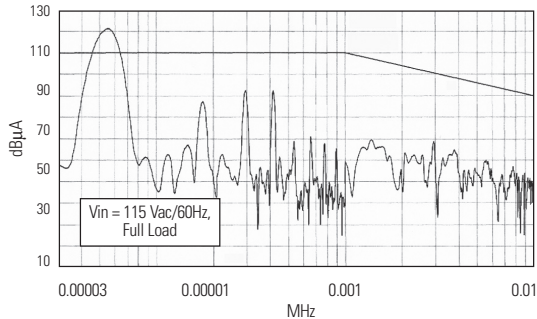

**23. MIL-STD-461D CE102-1**

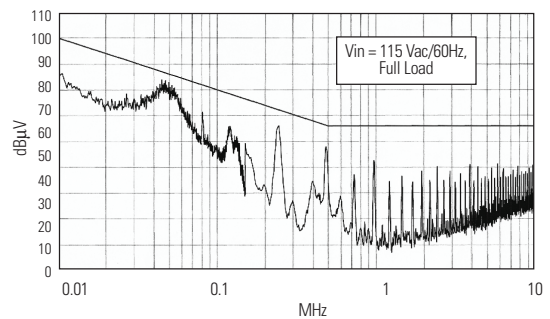

# BLOCK DIAGRAM OF MW75S

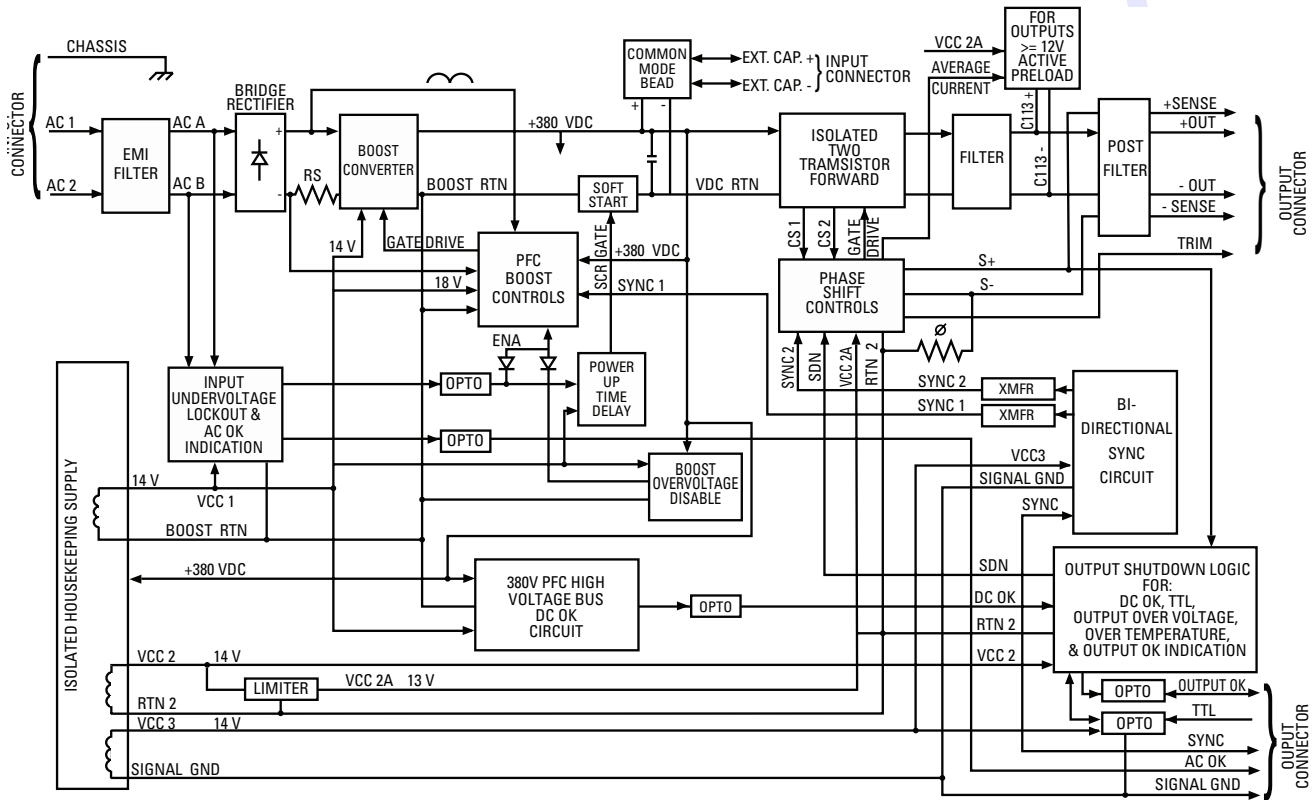

For additional information, call 310.542.8561  
or e-mail: [Orders-EP@eaton.com](mailto:Orders-EP@eaton.com)



**Eaton**  
1000 Eaton Boulevard  
Cleveland, OH 44122  
United States  
[Eaton.com](http://Eaton.com)

© 2017 Eaton  
All Rights Reserved  
Printed in USA  
March 2017

Eaton is a registered trademark.

All other trademarks are property  
of their respective owners.