

NB100S single and dual-output DC/DC converters

14 – 40Vin, 2 – 28Vout, 100 watts



How to Order:

NB 100 D I / 5 / 15 - A - D

Series	Output Voltages: One number is for single out or two numbers for dual output. Maximum current as stated in selection chart.	Options: A- pins out side of unit B- pins out bottom of unit C- pins out top of unit D- through hole inserts (STD threaded) I - M2.5 inserts
Total Output Power		
Single (S), Dual (D) Output		
Industrial (I) or Military (M)		

Model Numbering Example:

To order a 100 watt, 15 V out (single output), industrial grade power supply with pins out the side, the model number would be: NB100SI/15-A. Military grade would be NB100SM/15-A. To order a 100 watt, dual output, 15 V and 15 V, industrial grade power supply with pins out the top, the model number would be NB100DI/15/15-C. Dual output, 12 V and 15 V, military grade, would be NB100DM/12/15-C. When ordering a dual output unit, the first output voltage in the model number is located on channel 1, and the second output voltage in the model number is located on channel 2 (see case drawing for details).

INPUT CHARACTERISTICS

	PER CHANNEL			
	Min.	Typ.	Max.	Units
Input Voltage	14	28	40	Vdc
Brown Out (75% of Full Load) [fig. I]*		12		Vdc
No Load Power Dissipation		2	4	Watt
Inrush Charge [fig. VII]*			2	mc
Reflective Ripple Current [fig. VIII]*		15		%
Logic Disable Current (Sink)		100	150	µA
Logic Disable Power In		1.2	2.5	W
Input Ripple Rejection (120 Hz)		55		dB
Input Ripple Rejection (800 Hz)		45		dB
Efficiency up to		83		%

See Page 21 [fig. II, III]*

EMI: Units conform to MIL-STD-461D (on the input leads) with companion filter

Input Transient: Units conform to MIL-STD-704D for transients up to 50V for 0.1 second

STABILITY

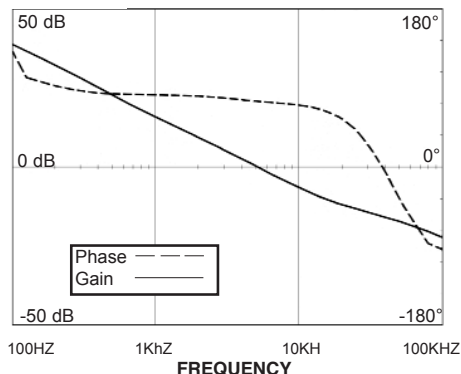

All specifications are typical @+25°C with nominal input voltage under full output load conditions, unless otherwise noted. Specifications subject to change without notice.

FEATURES

- .38 Inch Profile
- Synchronization
- Remote Turn On (TTL)
- Output Voltage Trim Pin
- Over Temperature Protection
- Output Overvoltage/Overcurrent Protection
- Built-In Test (Output Power Good; Main Output)
- 100% Environmental Screening (Military Version)
- Outputs Isolated Allowing Any Combination of Output Voltages

SELECTION CHART

Output Voltage and Output Current

Nominal Output Voltage	Single Output	Dual Per Channel
	Current (Amps)	Current (Amps)
2	20	10
3.3	20	10
5	20	10
5.2	19.2	9.6
12	8.3	4.2
15	6.7	3.3
24	4.2	2.1
28	3.6	1.8

OUTPUT CHARACTERISTICS

	PER CHANNEL			
	Min.	Typ.	Max.	Units
Set Point Accuracy			1 †	% V _{out}
Load Regulation		5	0.2% †	mV
Line Regulation		5	0.2% †	mV
Ripple P-P (10 MHz) (2V-24) [fig. IV]*		45	150	mV
Ripple P-P (10 MHz) (28V)[fig. IV]*		.2%	1%	% V _{out}
Trim Range	100		110	% V _{out}
Remote Sense Compensation			0.5	Vdc
Overvoltage Protection (2V, 3.3V)		140		% V _{out}
Overvoltage Protection (5V-28)		125		% V _{out}
Current Sharing		±10		% I _{out}
Transient Response (Vout 1%) Time/Overshoot [fig. V & VI]*				µS/mV
20-80% Load		350/300		µS/mV
Low Line - High Line		300/350		µS/mV
50-100% Load		250/300		µS/mV
Temperature Drift		0.01	0.05	%/°C
Long Term Drift		0.01	0.02	%/1KHrs
Current Limit	105	125	150	% I _{out}
Short Circuit Current	25		75	% I _{out}
Turn On Time [fig. XI]*		1.5		mS
Logic Turn On Time [fig. IX]*		1.5		mS

† 1% or 50mV, whichever is greater

* figures on page 21 represents per channel

† .2% or 25mv whichever is greater



Powering Business Worldwide

For additional information, call 310.542.8561
or e-mail: Orders-EP@eaton.com

www.eaton.com/powerconversion

Industrial & military grade high density DC to DC converters

TEMPERATURE CHARACTERISTICS

	Min.	Typ.	Max.	Units
Operating	-55		+100	°C
Storage (Ambient)	-55		+125	°C
Over Temperature Shutdown		+105		°C
Thermal Resistance Case - Ambient		12		°C/W

ENVIRONMENTAL SCREENING - M MODEL

Stabilization Bake:	+125°C for 24 hours similar to Mil-Std-883, M1008.2, Condition B
Temperature Cycling:	10 cycles at -55°C to +125°C (transition period 36 minutes) similar to Mil-Std-883, M1010, Condition B
Burn-in:	160 hours at +85°C min.
Final Testing	

ENVIRONMENTAL SCREENING - I MODEL

Burn-in:	16 hours at +85°C min.
Final Testing	

See "Guide to Operation" for full details.

ISOLATION CHARACTERISTICS

	Min.	Typ.	Units
Isolation:			
Input to Output	500		Vdc
Output to Base	250		Vdc
Input to Base	250		Vdc
Input to Output Capacitance		0.044	µf
Insulation Resistance (@50 Vdc)	50		MOhm

MECHANICAL CHARACTERISTICS

Weight	6.4	oz.
	180	grams
Size	3.0 x 3.0 x 0.38	inch
	76.2 x 76.2 x 9.7	mm
Volume	3.42	inch ³
	56.0	cm ³
Material	Pin	Brass (Solder Plating)
	Baseplate	Aluminum 5052-H32
	Case	28 Gauge Steel (cold rolled)
Finish		Nickel Plating
Mounting	Standard	4-40 inserts provided in baseplate
	I Option	M2.5 metric inserts (4 places)
	D Option	0.115 DIA thru holes (4 places)

CASE DRAWINGS

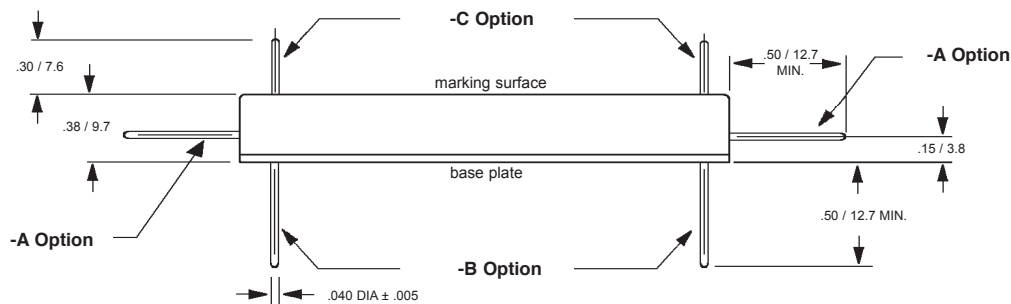
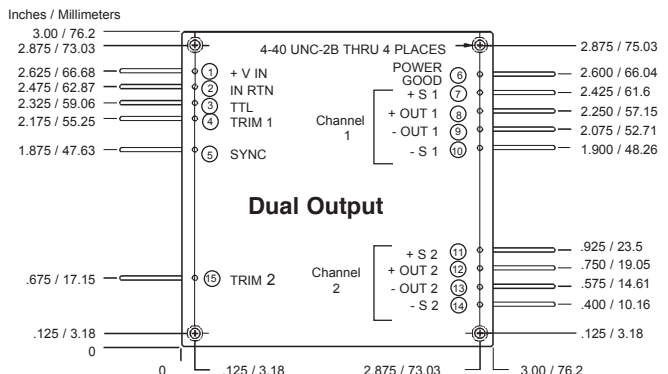
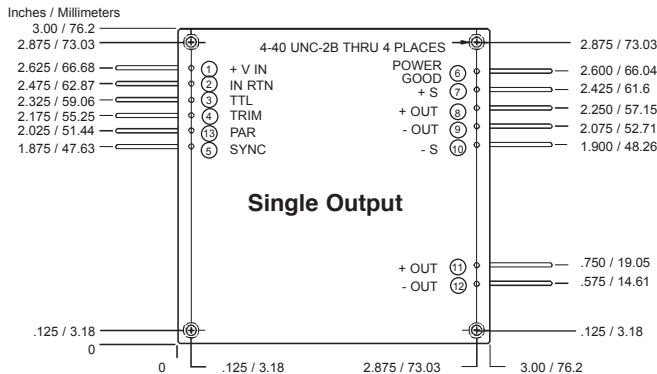

Tolerances: inches - x.xx = ±0.03 mm - x.x = ±0.8
x.xxx = ±0.015 x.xx = ±0.40

All specifications are typical @+25°C with nominal input voltage under full output load conditions, unless otherwise noted. Specifications subject to change without notice.

Performance characteristics

I. Input Voltage vs. Output Power

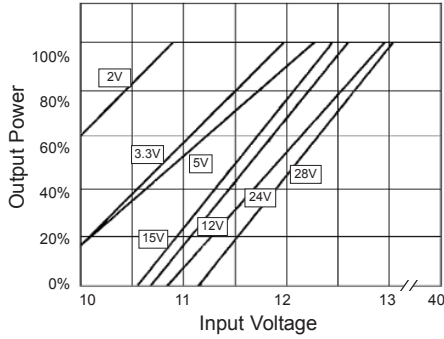

II. Efficiency vs. Output Power

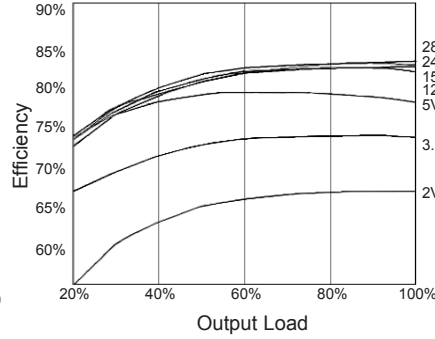

III. Efficiency vs. Input Voltage

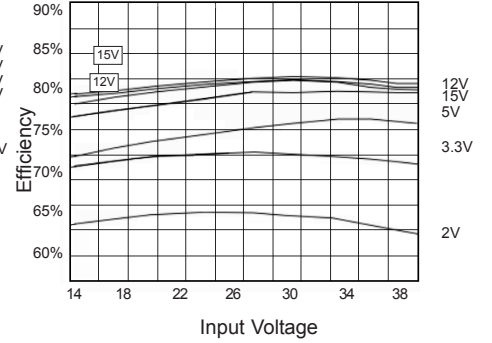

IV. Output Voltage Ripple

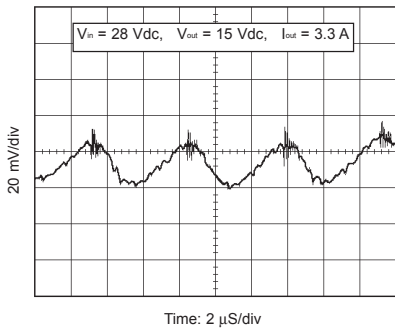

V. Load Transient Response

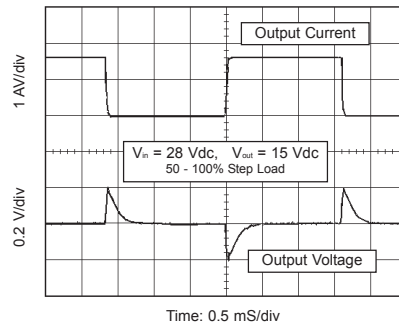

VI. Input Transient Response

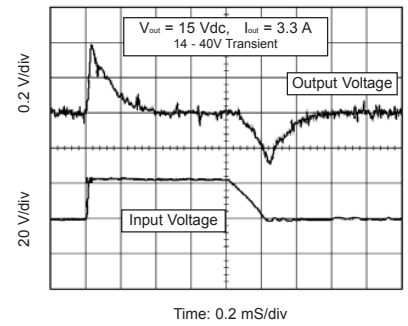

VII. Input Inrush Current

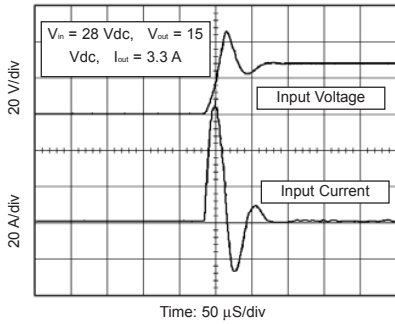

VIII. Input Current Ripple

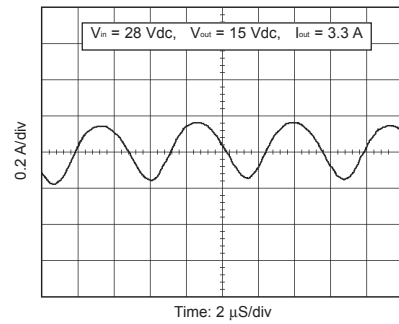

IX. TTL Turn On

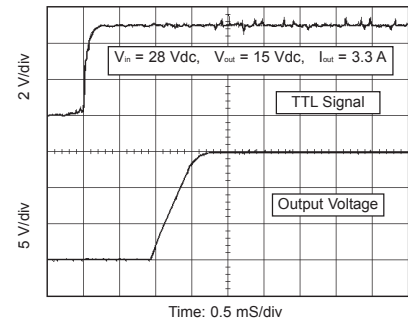

X. TTL Turn-off

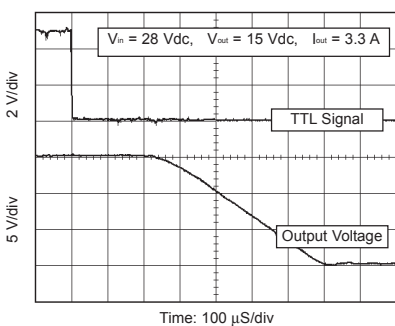

XI. Turn-on

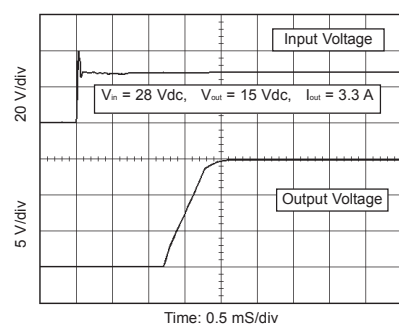

XII. Turn-off / Hold-up Time

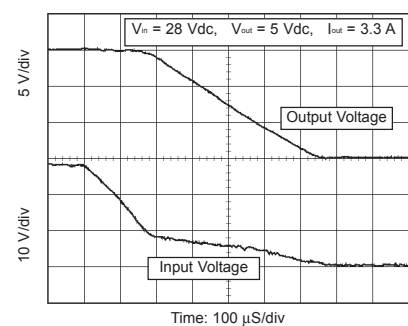

NBF150 EMI filters



How to Order:

NBF 150 - A - D

- Series
- Total Output Power
- Options:
 A- pins out side of unit
 B- pins out bottom of unit
 C- pins out top of unit
 D- through hole inserts (STD threaded)
 I - M2.5 inserts

EMI COMPARISON GRAPHS

28V_{in} - 150 watts
 MIL-STD-461D, CE101-4

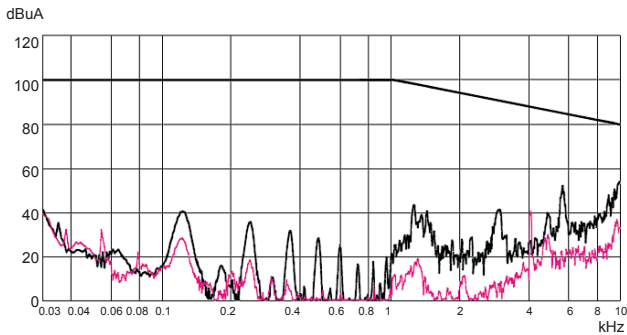

28V_{in} - 150 watts
 MIL-STD-461D, CE102

- With NBF50
 ■ Without NBF50

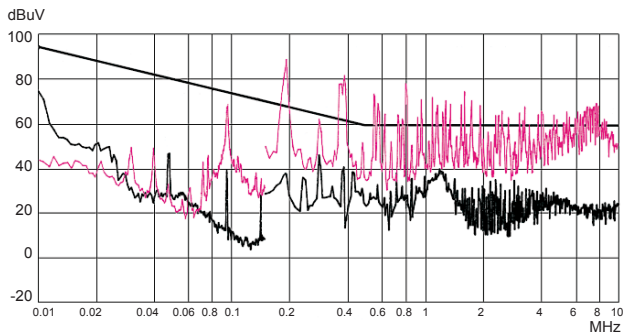

FEATURES

- MIL-STD-461D Compliance CE101 and CE102
- Does Not Require External Components
- Meets Environmental Requirements of MIL-STD-810E and MIL-S-901
- For Use With NB80, NB100, NB150 Series DC/DC Converters

SPECIFICATIONS

Input Voltage (maximum)	50	Vdc
Rated Output Current	15	A
Isolation (Input/Output to Case)	500	Vdc
Operating Temperature	-55 to +100	°C
Storage Temperature	-55 to +125	°C
Insulation Resistance (measured at 50Vdc)	50	M Ohm
Weight	4.2	oz.
	120	grams
Size	3.0 x 2.0 x 0.38	inch
	76.2 x 50.8 x 9.7	mm
Volume	2.28	inch ³
	37.5	cm ³
Material	Pin	Brass (Solder Plating)
	Baseplate	Aluminum 5052-H32
	Case	28 Gauge Steel (cold rolled)
Finish		Nickel Plating
Mounting	Standard	4-40 inserts provided in baseplate
	I Option	M2.5 metric inserts (4 places)
	D Option	0.115 DIA thru holes (4 places)

CASE DRAWINGS

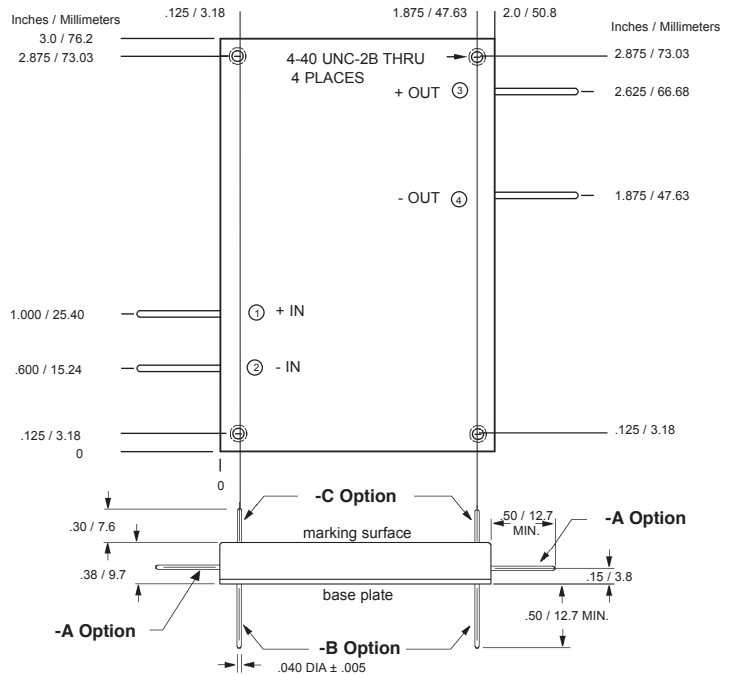

Tolerances:

inches	-	x.XX	= ±0.03
		x.XXX	= ±0.015
mm	-	x.X	= ±0.8
		x.XX	= ±0.40

All specifications are typical @+25°C with nominal input voltage under full output load conditions, unless otherwise noted. Specifications subject to change without notice.

For additional information, call 310.542.8561
or e-mail: Orders-EP@eaton.com



Eaton
1000 Eaton Boulevard
Cleveland, OH 44122
United States
Eaton.com

© 2017 Eaton
All Rights Reserved
March, 2017

Eaton is a registered trademark.

All other trademarks are property
of their respective owners.