

NB15S single-output DC/DC converters

14 – 40Vin, 2 – 15Vout, 15 watts



How to Order:

NB 15 S M / 5 - A - D

Series	Output Voltage: Maximum current as stated in chart	Options: A- pins out side of unit B- pins out bottom of unit C- pins out top of unit D- through hole inserts (STD threaded) I - M2.5 inserts
Total Output Power		
Single Output		
Industrial (I) or Military (M)		

INPUT CHARACTERISTICS

PER CHANNEL

	Min.	Typ.	Max.	Units
Input Voltage	14	28	40	Vdc
Brown Out (75% of Full Load) [fig. I]*		12		Vdc
No Load Power Dissipation		1	2	Watt
Inrush Charge [fig. VII]*			1	mc
Reflective Ripple Current [fig. VIII]*		22		%
Logic Disable Current (Sink)		100	150	μA
Logic Disable Power In		1	2	W
Input Ripple Rejection (120 Hz)		55		dB
Input Ripple Rejection (800 Hz)		40		dB
Efficiency up to		82		%

See Page 20 [fig. II, III]*

EMI: Units conform to MIL-STD-461D (on the input leads) with companion filter

Input Transient: Units conform to MIL-STD-704D for transients up to 50V for 0.1 sec.

STABILITY

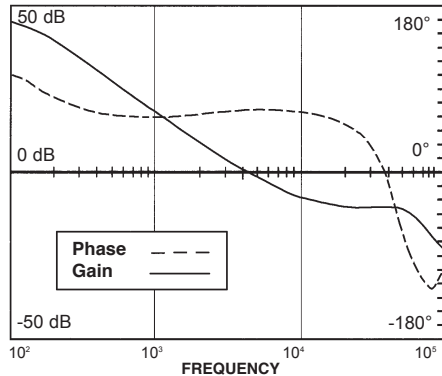

FEATURES

- .38 Inch Profile
- Remote Turn On (TTL)
- Output Voltage Trim Pin
- Over Temperature Protection
- Output Overvoltage/Overcurrent Protection
- 100% Environmental Screening (Military Version)

SELECTION CHART

Nominal Output Voltage	Output Current (Amps)	Model Number (Industrial)	Model Number (Military)
2	3.0	NB15SI/2-A	NB15SM/2-A
3.3	3.0	NB15SI/3.3-A	NB15SM/3.3-A
5	3.0	NB15SI/5-A	NB15SM/5-A
5.2	2.9	NB15SI/5.2-A	NB15SM/5.2-A
12	1.25	NB15SI/12-A	NB15SM/12-A
15	1.0	NB15SI/15-A	NB15SM/15-A

OUTPUT CHARACTERISTICS

PER CHANNEL

	Min.	Typ.	Max.	Units
Set Point Accuracy			1 †	% V _{out}
Load Regulation		5	25	mV
Line Regulation		5	25	mV
Ripple P-P (10 MHz) [fig. IV]*		50	100	mV
Trim Range	100		110	% V _{out}
Overvoltage Protection		125		% V _{out}
Transient Response (V _{out} 1%) Time/Overshoot [fig. V & VI]*				
20-80% Load		350/250		μS/mV
Low Line - High Line		300/300		μS/mV
50-100% Load		250/200		μS/mV
Temperature Drift		0.01	0.05	%/°C
Long Term Drift		0.01	0.02	%/1KHrs
Current Limit	105	125	150	% I _{out}
Short Circuit Current	25		75	% I _{out}
Turn On Time [fig. XI]*		2		mS
Logic Turn On Time [fig. IX]*		2		mS

† 1% or 50mV, whichever is greater

* figures on page 20

All specifications are typical @+25°C with nominal input voltage under full output load conditions, unless otherwise noted. Specifications subject to change without notice.



Powering Business Worldwide

For additional information, call 310.542.8561
or e-mail: Orders-EP@eaton.com

www.eaton.com/powerconversion

Industrial & military grade high density DC to DC converters

TEMPERATURE CHARACTERISTICS

	Min.	Typ.	Max.	Units
Operating	-55		+100	°C
Storage (Ambient)	-55		+125	°C
Over Temperature Shutdown		+105		°C
Thermal Resistance Case - Ambient		12		°C/W

ENVIRONMENTAL SCREENING - M MODEL

Stabilization Bake:	+125°C for 24 hours similar to Mil-Std-883, M1008.2, Condition B
Temperature Cycling:	10 cycles at -55°C to +125°C (transition period 36 minutes) similar to Mil-Std-883, M1010, Condition B
Burn-in:	160 hours at +85°C min.
Final Testing	

ENVIRONMENTAL SCREENING - I MODEL

Burn-in:	16 hours at +85°C min.
Final Testing	

See "Guide to Operation" for full details.

ISOLATION CHARACTERISTICS

	Min.	Typ.	Max.	Units
Isolation:				
Input to Output	500			Vdc
Output to Base	250			Vdc
Input to Base	250			Vdc
Input to Output Capacitance		0.022		µF
Insulation Resistance (@50 Vdc)	50			MOhm

MECHANICAL CHARACTERISTICS

Weight	1.8	oz.
	50	grams
Size	3.0 x 1.0 x 0.38	inch
	76.2 x 25.4 x 9.7	mm
Volume	1.14	inch ³
	18.7	cm ³
Material	Pin	Brass (Solder Plating)
	Baseplate	Aluminum 5052-H32
	Case	28 Gauge Steel (cold rolled)
Finish		Nickel Plating
Mounting	Standard	4-40 inserts provided in baseplate
	I Option	M2.5 metric inserts (3 places)
	D Option	0.115 DIA thru holes (3 places)

CASE DRAWINGS

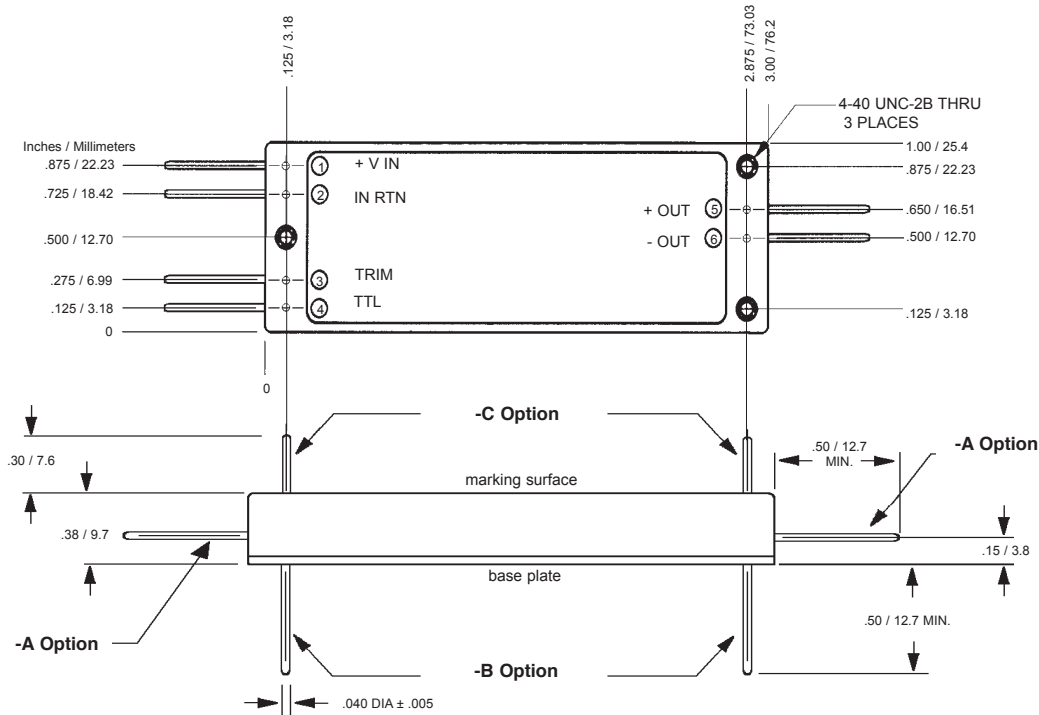

Tolerances: inches - x.xx = ±0.03 mm - x.x = ±0.8
 x.xxx = ±0.015 x.xx = ±0.40

All specifications are typical @+25°C with nominal input voltage under full output load conditions, unless otherwise noted. Specifications subject to change without notice.

Performance characteristics

I. Input Voltage vs. Output Power

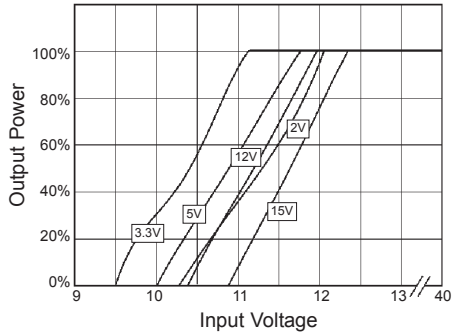

II. Efficiency vs. Output Power

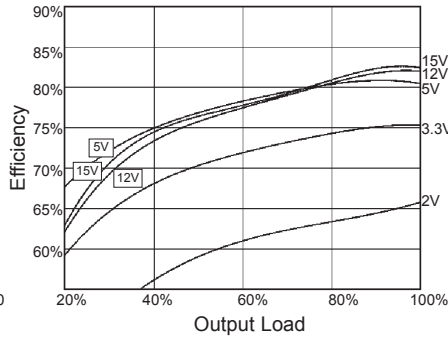

III. Efficiency vs. Input Voltage

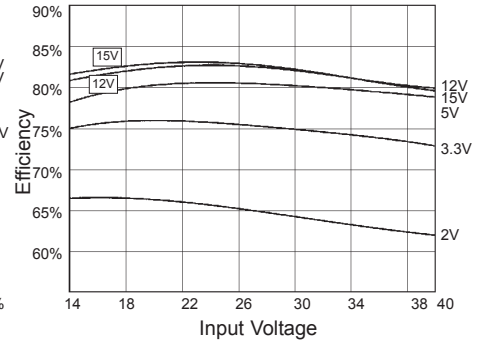

IV. Output Voltage Ripple

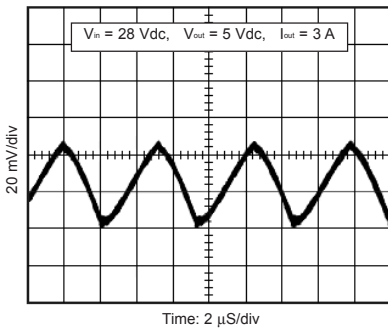

V. Load Transient Response

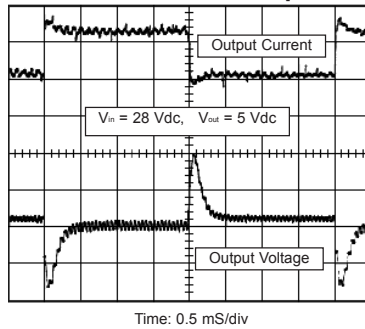

VI. Input Transient Response

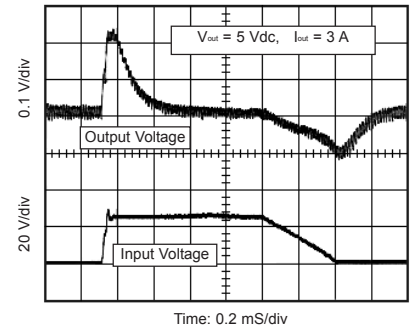

VII. Input Inrush Current

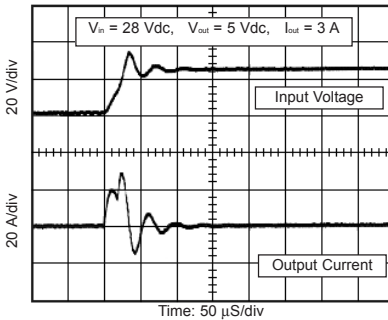

VIII. Input Current Ripple

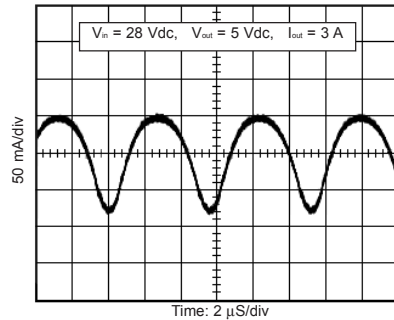

IX. TTL Turn On

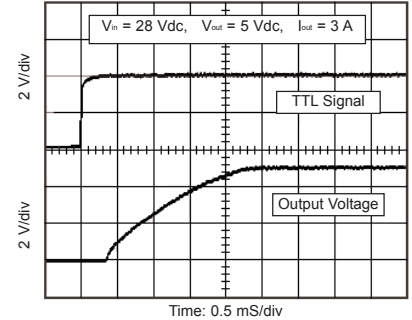

X. TTL Turn-off

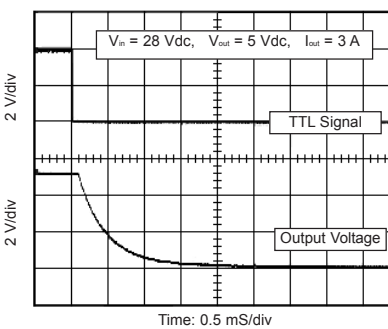

XI. Turn-on

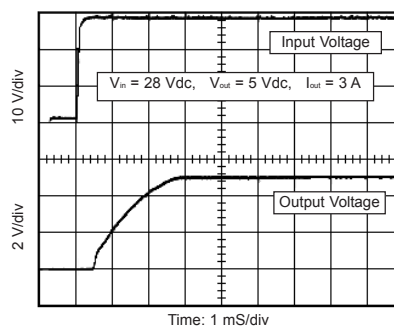

XII. Turn-off / Hold-up Time

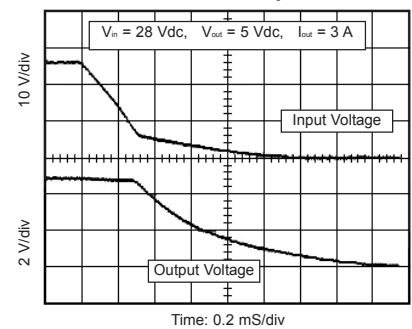

NHF150 EMI filters



How to Order:

NBF 50 - A - D

Series
Total Output Power

Options:
A- pins out side of unit
B- pins out bottom of unit
C- pins out top of unit
D- through hole inserts
(STD threaded)
I - M2.5 inserts

EMI COMPARISON GRAPHS

28V_{in} - 50 watts
MIL-STD-461D, CE101-4

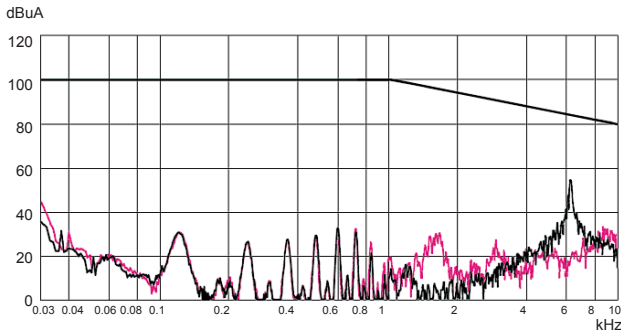

28V_{in} - 50 watts
MIL-STD-461D, CE102

■ With NBF50
■ Without NBF50

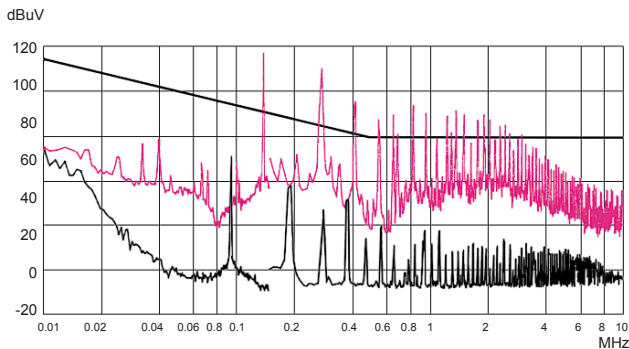

FEATURES

- MIL-STD-461D Compliance CE101 and CE102
- Thermally Non-dissipative device
- Less than 1.0 volt drop across the NBF50
- Does Not Require External Components
- Meets Environmental Requirements of MIL-STD-810E and MIL-STD-901C
- For Use With NB15, NB30, NB45 and NB50 Series DC/DC Converters

SPECIFICATIONS

Input Voltage (maximum)	50	Vdc
Rated Output Current	5	A
Isolation (Input/Output to Case)	500	Vdc
Operating Temperature	-55 to + 100	°C
Storage Temperature	-55 to + 125	°C
Insulation Resistance (measured at 50Vdc)	50	M Ohm
Weight	1.98	oz.
	56.0	grams
Size	1.75 x 1.5 x 0.38	inch
	44.5 x 38.1 x 9.7	mm
Volume	1.00	inch ³
	16.5	cm ³
Material	Pin	Brass (Solder Plating)
	Baseplate	Aluminum 5052-H32
	Case	28 Gauge Steel (cold rolled)
Finish		Nickel Plating
Mounting	Standard	4-40 inserts provided in baseplate
	I Option	M2.5 metric inserts (4 places)
	D Option	0.115 DIA thru holes (4 places)

CASE DRAWING

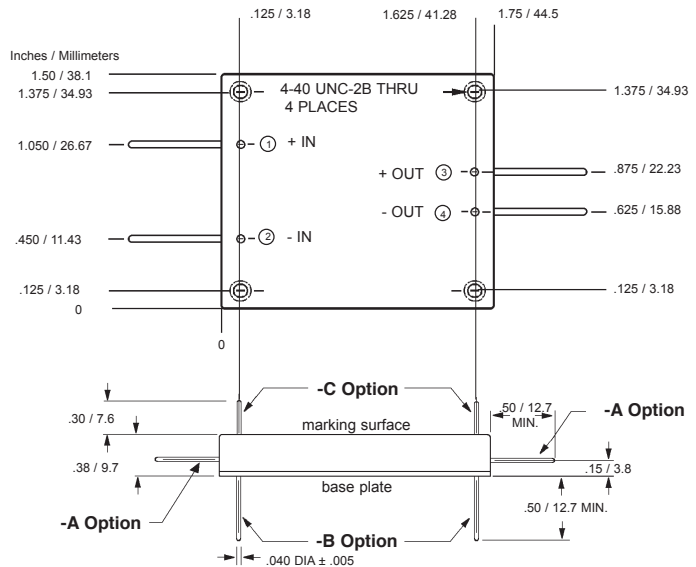

Tolerances:	inches	-	x.xx	= ±0.03
			x.xxx	= ±0.015
	mm	-	x.x	= ±0.8
			x.xx	= ±0.40

All specifications are typical @+25°C with nominal input voltage under full output load conditions, unless otherwise noted. Specifications subject to change without notice.

For additional information, call 310.542.8561
or e-mail: Orders-EP@eaton.com



Eaton
1000 Eaton Boulevard
Cleveland, OH 44122
United States
Eaton.com

© 2017 Eaton
All Rights Reserved
March, 2017

Eaton is a registered trademark.

All other trademarks are property
of their respective owners.