

NH150 single and triple-output DC/DC converters

200 – 400Vin, 2 – 28Vout, 150 watts



How to Order:

NH 150 T M / 5/12/15 - A - D

Series	Output Voltage:	Options:
Total Output Power	Maximum current as stated in chart	A- pins out side of unit B- pins out bottom of unit C- pins out top of unit D- through hole inserts (STD threaded) I - M2.5 inserts
Single (S), Triple (T) Output		
Industrial (I) or Military (M)		

Model Numbering Example:

To order a 150 watt, 15 Vout (single output), industrial grade power supply with pins out the bottom, the model number would be: NH150SI/15-B. Military grade would be NH150SM/15-B. To order a 150 watt, triple output, 15 Vdc and 15 Vdc and 5.2 Vdc, industrial grade power supply with pins out of the top, the model number would be: NH150TI/15/15/5.2-C. Triple output, 12 Vdc and 15 Vdc and 3.3 Vout, military grade, would be NH150TM/12/15/3.3-C. When ordering a Triple output unit, the first output voltage in the model number is located on channel 1 and the second output voltage is located on channel 2, and the third is located on channel 3 (see case drawing for details).

INPUT CHARACTERISTICS

	PER CHANNEL			Units
	Min.	Typ.	Max.	
Input Voltage	200	270	400	Vdc
Brown Out (75% of Full Load) (fig. I)*	180			Vdc
No Load Power Dissipation		6	9	Watt
Inrush Charge (fig. VII)*		0.36	0.6	mc
Reflective Ripple Current (fig. VIII)*		300		mA
Logic Disable Current (Sink)		15		mA
Logic Disable Power In		6	7	W
Input Ripple Rejection (120 Hz)		75		dB
Input Ripple Rejection (800 Hz)		60		dB
Efficiency (FL) (fig. II, III)*	75	80		%
3.3 Vdc Output (FL)	70	74		%
2 Vdc Output (FL)	60	65		%

EMI: Units conform to MIL-STD-461D (on the input leads) with companion filter

Input Transient: Units conform to MIL-STD-704D for transients up to 500V for 0.1 second

STABILITY

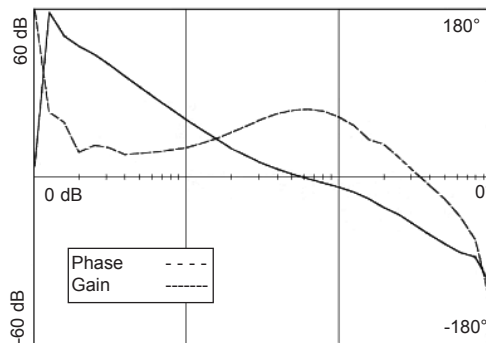

FEATURES

- .38 Inch Profile
- Power Good***
- Synchronization**
- Remote Turn On (TTL)***
- Output Voltage Trim Pin**
- Single and Triple Outputs
- Over Temperature Protection
- N+1 Redundancy (Single Output)
- Output Overvoltage/Overcurrent Protection
- 100% Environmental Screening (Military Version)
- Outputs Isolated Allowing Any Combination of Output Voltages

SELECTION CHART

Nominal Output Voltage	Single Output Current (Amps)	Triple Per Channel Current (Amps)
2	30	10
3.3	30	10
5	30	10
5.2	28.8	9.6
12	12.6	4.2
15	10	3.3
24	6.3	2.1
28	5.4	1.8

OUTPUT CHARACTERISTICS

	PER CHANNEL			Units
	Min.	Typ.	Max.	
Set Point Accuracy			1 †	% V _{out}
Load Regulation			0.5	% V _{out}
Line Regulation			0.5	% V _{out}
Ripple P-P (10 MHz) (fig. IV)*			100	mV
<i>100mV or 1% Vout, whichever is greater</i>				
Trim Range		±10		% V _{out}
Remote Sense Compensation		0.5		Vdc
Overvoltage Protection		125		% V _{out}
Current Sharing		±10		% I _{out}
Transient Response (Recovery to 1%Vout) Time/Overshoot				
20-80% Load		500/500		µS/mV
Low Line - High Line		500/500		µS/mV
50-100% Load		500/500		µS/mV
Temperature Drift		.05		%/°C
Long Term Drift		.05		%/1KHrs
Current Limit		130		% I _{out}
Short Circuit Current (Burp Mode)	25		75	% I _{out}
Turn On Time (fig. XI)*		60		mS
Logic Turn On Time (fig. IX)*		1.0		mS

† 1% or 50mV, whichever is greater

* Figures on page 10

** Features referenced to output ground.

*** Features referenced to Channel 1 Output Ground



Powering Business Worldwide

For additional information, call 310.542.8561
or e-mail: Orders-EP@eaton.com

www.eaton.com/powerconversion

Industrial & military grade high density DC to DC converters

TEMPERATURE CHARACTERISTICS

	Min.	Typ.	Max.	Units
Operating	-55		+100	°C
Storage (Ambient)	-55		+125	°C
Over Temperature Shutdown		+105		°C
Thermal Resistance Case - Ambient		11		°C/W

ENVIRONMENTAL SCREENING - M MODEL

Stabilization Bake:	+125°C for 24 hours similar to Mil-Std-883, M1008.2, Condition B
Temperature Cycling:	10 cycles at -55°C to +125°C (transition period 36 minutes) similar to Mil-Std-883, M1010, Condition B
Burn-in:	160 hours at +85°C min.
Final Testing	

ENVIRONMENTAL SCREENING - I MODEL

Burn-in:	16 hours at +85°C min.
Final Testing	

See "Guide to Operation" for full details

ISOLATION CHARACTERISTICS

	Min.	Typ.	Max.	Units
Isolation:				
Input to Output	1000			Vdc
Output to Base	500			Vdc
Input to Base	1000			Vdc
Input to Output Capacitance (single)		0.066		µf
Input to Output Capacitance (triple)		0.022		µf
Insulation Resistance (@50 Vdc)	50			MOhm

MECHANICAL CHARACTERISTICS

Weight	12.6	oz.
	360	grams
Size	3.0 x 6.0 x 0.38	inch
	76.2 x 152.4 x 9.7	mm
Volume	6.84	inch ³
	112.6	cm ³
Material	Pin	Brass (Solder Plating)
	Baseplate	Aluminum 5052-H32
	Case	28 Gauge Steel (cold rolled)
Finish		Nickel Plating
Mounting	Standard	4-40 inserts provided in baseplate
	I Option	M2.5 metric inserts (8 places)
	D Option	0.115 DIA thru holes (8 places)

CASE DRAWINGS

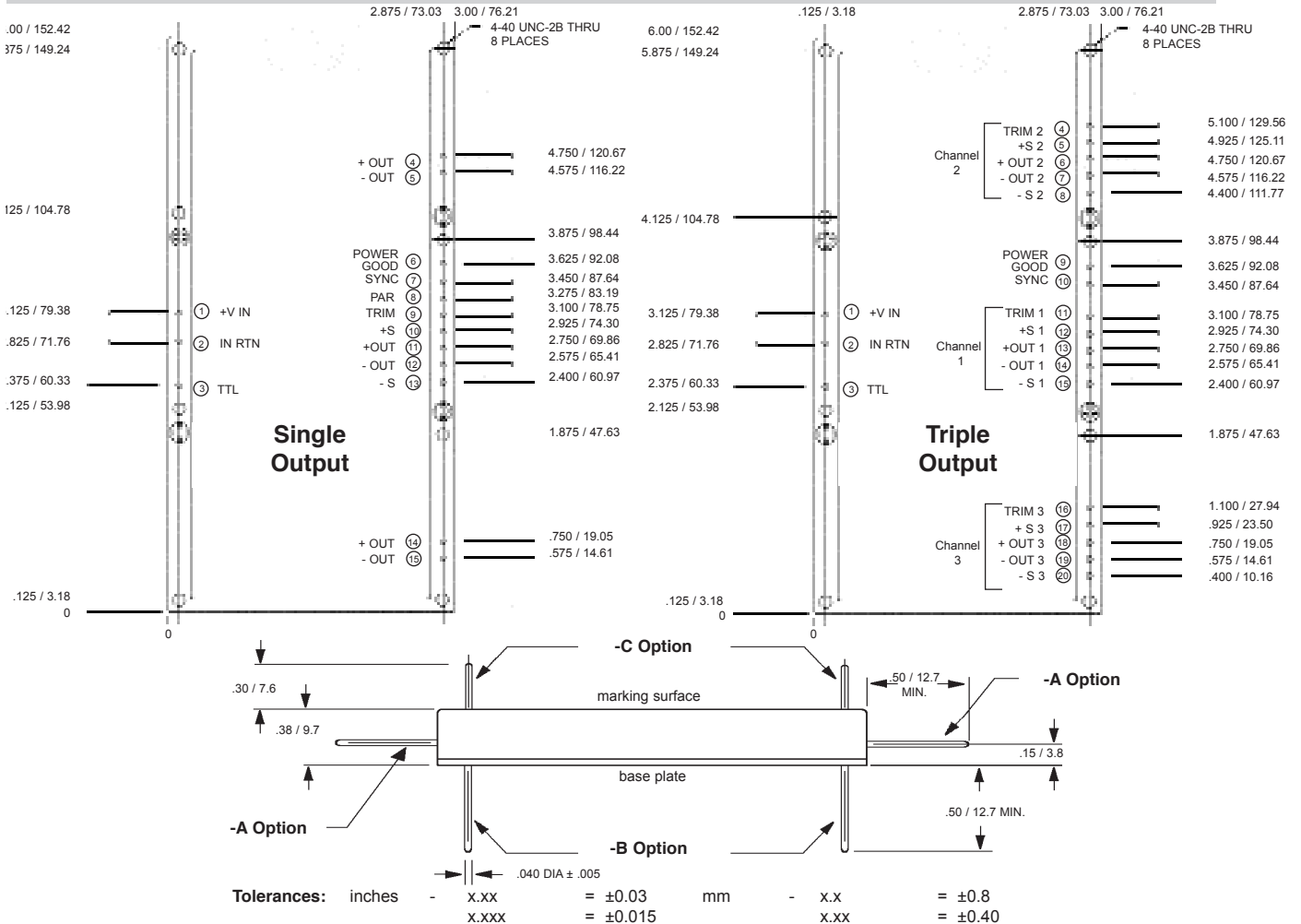

NH performance characteristics

I. Input Voltage vs. Output Power

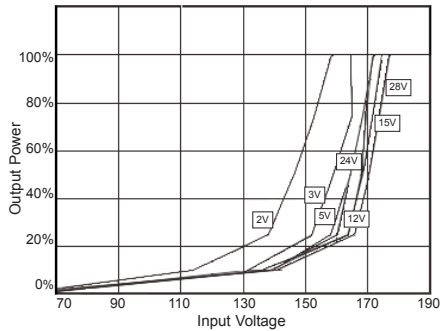

I. Efficiency vs. Load

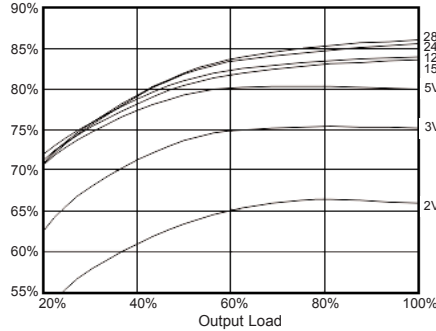

III. Efficiency vs. Line Voltage

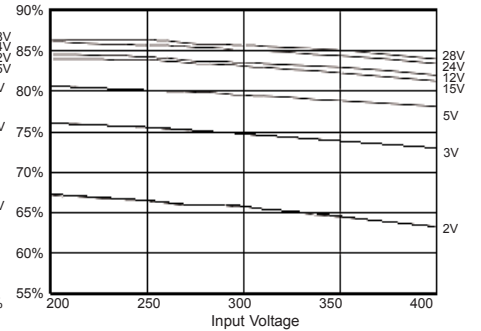

IV. Output Voltage Ripple

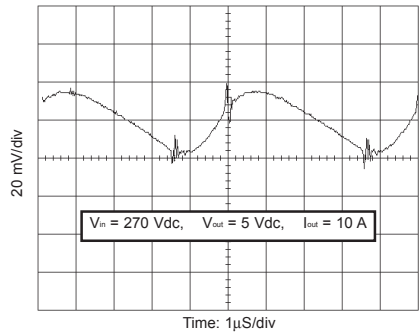

V. Load Transient Response

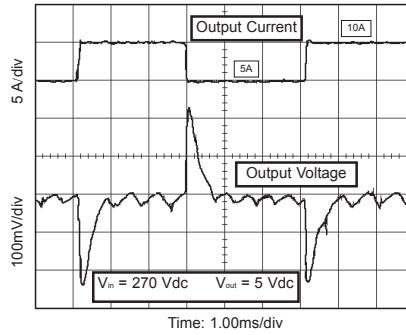

VI. Input Transient Response

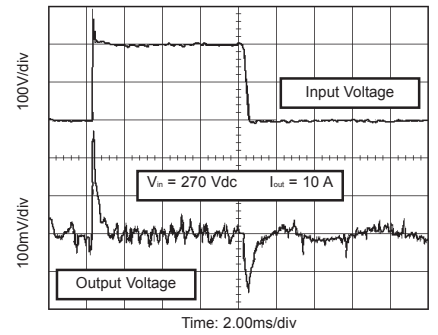

VII. Input Inrush Current

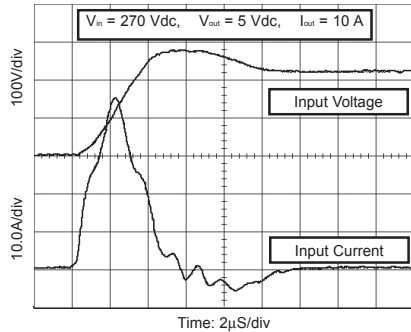

VIII. Input Current Ripple

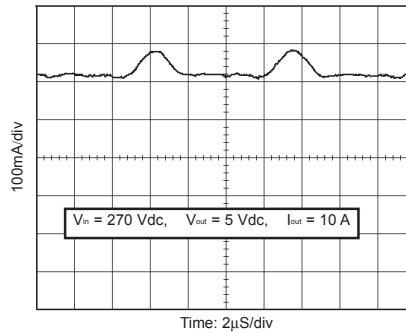

IX. TTL Turn On

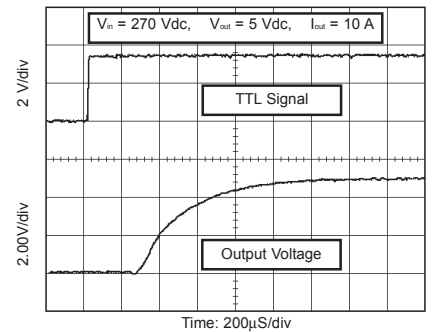

X. TTL Turn-off

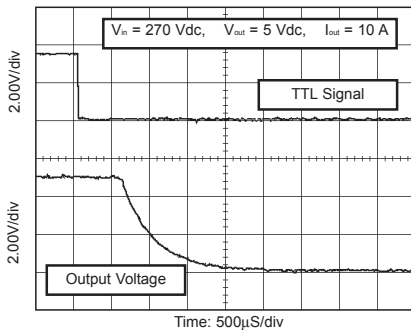

XI. Turn On

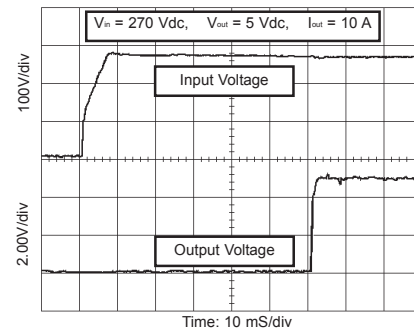

XI. Turn Off / Hold-up Time

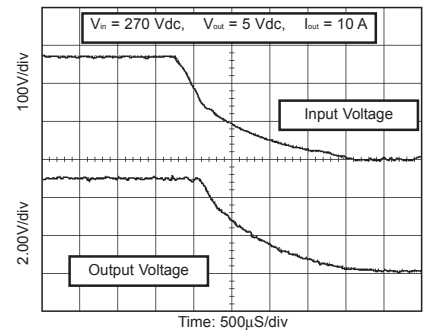

NH150 EMI filters



How to Order:

NHF 150 - A - D

Series	Options:
Total Output Power	A- pins out side of unit
	B- pins out bottom of unit
	C- pins out top of unit
	D- through hole inserts (STD threaded)
	I - M2.5 inserts

SPECIFICATIONS

Input Voltage (Maximum)	500	Vdc
Rated Output Current	1	A
Isolation (Input/Output to Case)	1000	Vdc
Operating Temperature	100	°C
Storage Temperature	125	°C
Insulation Resistance (measured @ 50Vdc)	50	M Ohm
Weight	1.72	oz.
	48.65	grams
Size	1.75 x 1.5 x 0.38	inch
	44.5 x 38.1 x 9.7	mm
Volume	1.00	inch ³
	16.5	cm ³
Material	Pin	Brass (Solder Plating)
	Baseplate	Aluminum 5052-H32
	Case	28 Gauge Steel (cold rolled)
Finish		Nickel Plating
Mounting	Standard:	4-40 inserts provided in basplate
	I Option:	M2.5 metric inserts (4 places)
	D Option:	0.115 DIA thru holes (4 places)

FEATURES

- MIL-STD-461D Compliance CE101 and CE102
- Thermally Non-dissipative device
- Less than 1.0 Volt Drop Across the NHF150
- Does Not Require External Components
- Meets Environmental Requirements of MIL-STD-810E and MIL-STD-901C
- For Use With NH50, NH100, and NH150 Series DC/DC Converters

CASE DRAWINGS

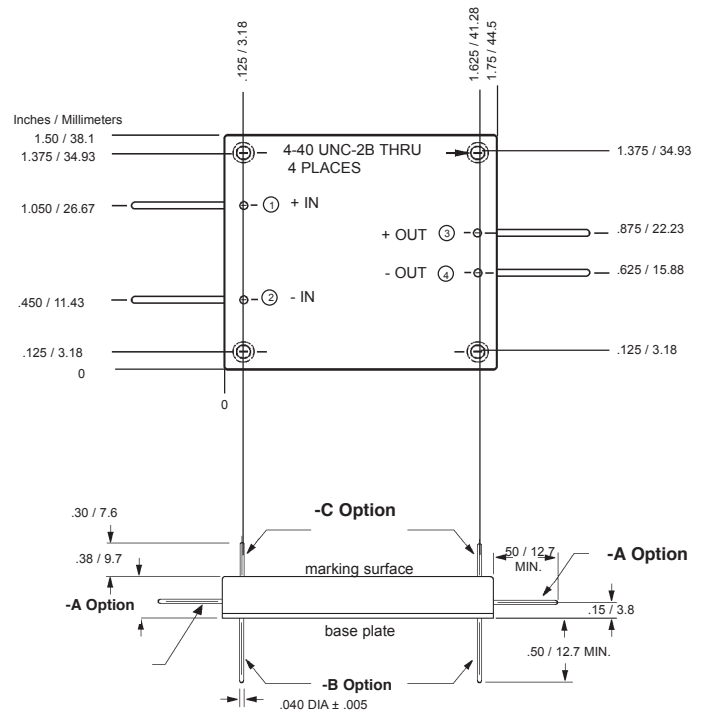

Tolerances:	inches	-	X.XX	= ±0.03
			X.XXX	= ±0.015
	mm		∅	= ±0.0

EMI compliance graphs

Mil-STD-461D, CE101

270 V_{in} - 150 watts

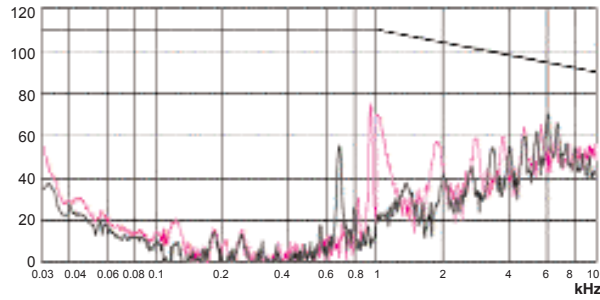

270 V_{in} - 50 watts

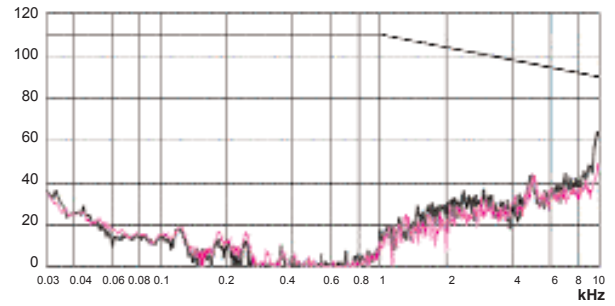

- Without NHF150
- With NHF150

Mil-STD-461D, CE102

270 V_{in} - 150 watts

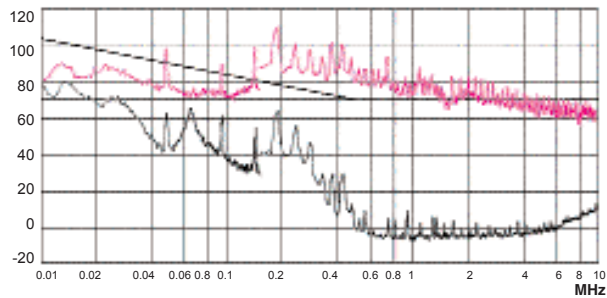

270 V_{in} - 50 watts

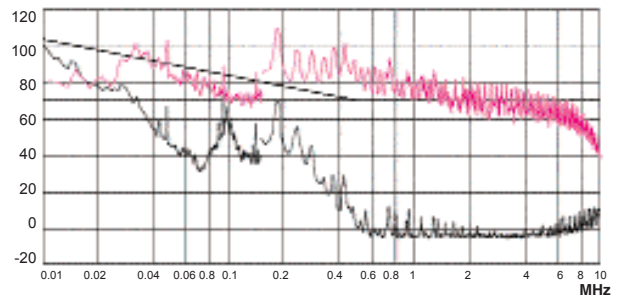

- Without NHF150
- With NHF150

For additional information, call 310.542.8561
or e-mail: Orders-EP@eaton.com

Eaton
1000 Eaton Boulevard
Cleveland, OH 44122
United States
Eaton.com

© 2017 Eaton
All Rights Reserved
Printed in USA
March 2017

Eaton is a registered trademark.

All other trademarks are property
of their respective owners.

