

SMH100S single-output DC/DC converters

18 – 36Vin and 200 – 400Vin, 2 – 48Vout, 100 watts



FEATURES

- No Derating From -55 to +100°C
- Synchronization
- Fixed Frequency Power Conversion
- MIL - STD - 883C Screening Available
- Meets MIL - Standards:
 - MIL - STD - 454
 - P4855 - 1A
 - MIL - STD - 704D
 - MIL - STD - 810E
 - MIL - S - 901C

HOW TO ORDER

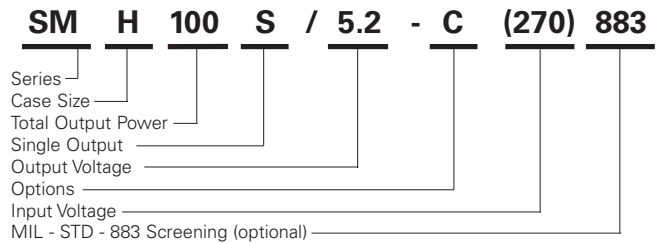

Options: **A** - pins out baseplate of unit Case Size: H designates the half size unit.
C - thru hole inserts (0.140 DIA) Omit the H for the larger case.
I - metric inserts (M3)

Standard unit is 28 Vdc nominal input with pins out the top written as SMH100S/5.2

ACCESSORY PRODUCTS

- SM1275: Input Transient Suppression Module (for 28 Vdc input only) for conformance to MIL - STD - 704A & MIL - STD - 1275.
- SMF200: EMI Filter to meet MIL - STD - 461C.
- SMR: AC Front End Rectifier (for 270 Vdc input).

SELECTION CHART

Nominal Output(Vdc)	Output Current(Amps)	Model Number
2.0	20	SMH100S/2.0
3.3	20	SMH100S/3.3
5.0	20	SMH100S/5.0
5.2	19	SMH100S/5.2
12	8.3	SMH100S/12
15	6.7	SMH100S/15
24	4.2	SMH100S/24
28	3.6	SMH100S/28
48	2.0	SMH100S/48

All specifications are typical @+25°C with nominal input voltage under full output load conditions, unless otherwise noted. Specifications subject to change without notice.

Specifications SMH100S

INPUT CHARACTERISTICS 28 VDC INPUT

	Min	Typ	Max	Units
Input Voltage	18	28	36	Vdc
Brown Out (75%) Full Load	17			Vdc
No Load Power Dissipation		3	6	Watt
Inrush Charge		2		mc
Reflected Ripple Current		15		%
Logic Disable Current (Sink)		1.0	1.5	mA
Logic Disable Power In		0.35	0.75	W
Input Ripple Rejection (120Hz)		60		dB
Input Overvoltage (No Damage)	37		50	Vdc
Efficiency up to		83		%
EMI	Units conform to MIL-STD-461C (on the input leads) with companion filter			
Input Transient	Units conform to MIL-STD-704D (50 Vdc for 0.1 second)			

INPUT CHARACTERISTICS 270VDC INPUT

	Min	Typ	Max	Units
Input Voltage	200	270	400	Vdc
Brown Out (75%) Full Load	175			Vdc
No Load Power Dissipation		10	15	Watt
Inrush Charge		1.5		mc
Reflected Ripple Current		15		%
Logic Disable Current (Sink)		0.8		mA
Logic Disable Power In		3.0		W
Input Ripple Rejection (120Hz)		60		dB
Input Overvoltage (No Damage)	400		500	Vdc
Efficiency up to		87		%
EMI	Units conform to MIL-STD-461C (on the input leads) with companion filter			
Input Transient	Units conform to MIL-STD-704D (500 Vdc for 0.1 second)			

OUTPUT CHARACTERISTICS

	Per Channel			Units
	Min	Typ	Max	
Set Point Accuracy			1*	%V _{out}
Load Regulation		0.02	0.2	%V _{out}
Line Regulation		0.02	0.1	%V _{out}
Ripple P-P (25MHz)		1.0	3.0	%V _{out}
Trim Range (5V, 5.2V min=85%)	60		115	%V _{out}
Trim Range (2V, 3.3V)	100		115	%V _{out}
Remote Sense Compensation		0.5		Vdc
Overvoltage Protection		115	125	%V _{out}
Current Sharing		N / A		
Transient Response (V _{out} 1%)	Time / Overshoot			
	20 - 80% Load	400/400		μS/mV
	Low Line - High Line	400/400		μS/mV
	50 - 100%	400/400		μS/mV
Temperature Drift		0.01	0.02	%/°C
Long Term Drift		0.01	0.02	%/1KHrs
Current Limit	105		150	%I _{out}
Short Circuit Current		180		%I _{out}
Turn On Time		25		mS
Logic Turn On Time		25		mS
Tracking Accuracy		N / A		

* 1% or 50mV, whichever is greater

ISOLATION CHARACTERISTICS

	Min	Typ	Max	Units
Isolation: Input to Output (28 Vdc in)	500			Vdc
Input to Output (270Vdc in)	1000			Vdc
Output to Base	500			Vdc
Input to Base (28 Vdc in)	500			Vdc
Input to Base (270 Vdc in)	1000			Vdc
Input to Output Capacitance	0.01		0.03	μF
Insulation Resistance (@ 50 Vdc)	50			MOhm

MECHANICAL CHARACTERISTICS

Weight	4.5	oz
	130	grams
Size	2.4 x 2.3 x 0.5	inch
	61 x 59 x 13	mm
Volume	2.76	inch ³
	47	cm ³

TEMPERATURE CHARACTERISTICS

	Min	Typ	Max	Units
Operating (Baseplate)	-55		+100	°C
Storage (Ambient)	-55		+125	°C
Over Temperature Shutdown		+105		°C
Thermal Resistance Case(Ambient)		5		°C/W

MIL - STD - 883 SCREENING (OPTIONAL)

Stabilization Bake:	+125°C for 24 hours per M1008.2, Condition B
Temperature Cycling:	10 cycles at -55°C to +125°C (transition period 36 minutes) per M1010, Condition B
Burn-in:	160 hours at +100°C
Final Testing	

All specifications are typical @+25°C with nominal input voltage under full output load conditions, unless otherwise noted. Specifications subject to change without notice.

Case drawings SMH100S

Standard Model

Pin placement on top of unit.
Model number written as SMH100S/5.2

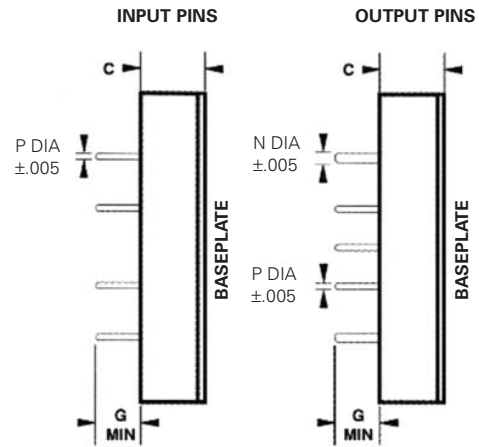
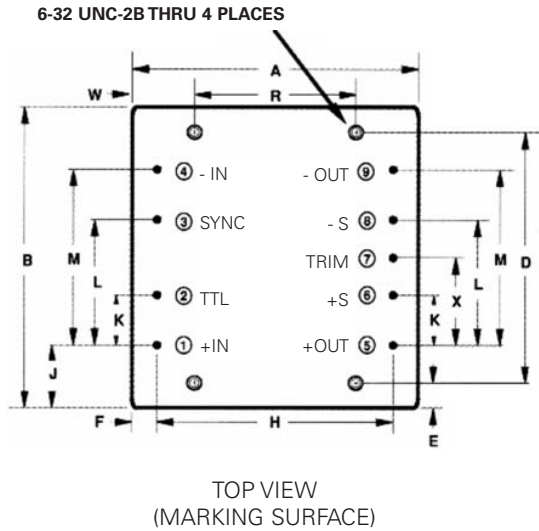

A Option

Pin placement on baseplate of unit.
Model number written as SMH100S/5.2-A

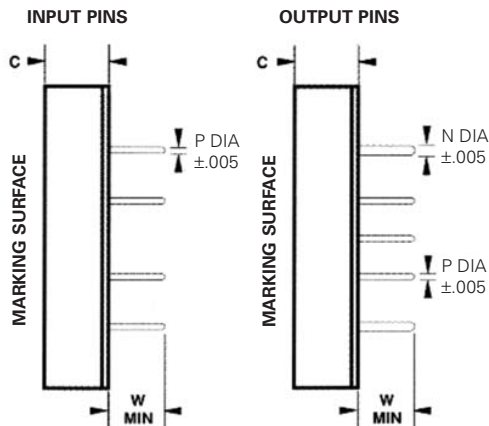

C Option

Thru hole inserts (0.140 DIA).
Model number written as SMH100S/5.2-C

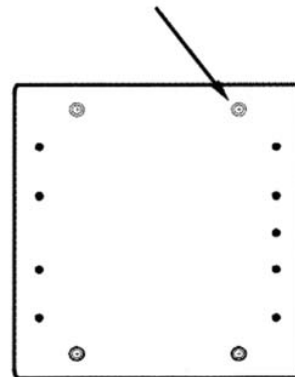

	A	B	C	D	E	F	G	H	J	K	L	M	N	P	R	W	X
inch	2.30	2.40	.50	2.100	.15	.20	.30	1.900	.50	.400	1.000	1.400	.080	.040	1.300	.50	.700
mm	58.4	61.0	12.7	53.34	3.8	5.1	7.6	48.26	12.7	10.20	25.40	35.56	2.03	1.02	33.02	12.7	17.80

Tolerances: Inches x.xx = ±0.03
x.xxx = ±0.015
mm x.xx = ±0.4
x.x = ±0.8

Material: Pin - Brass (Solder Plating), Baseplate - Aluminum 5052-H32,
Case - Steel.
Finish: Nickel Plating.
Mounting: 6-32 THD inserts are provided in baseplate.
Metric: M3 inserts.

All specifications are typical @+25°C with nominal input voltage under full output load conditions, unless otherwise noted. Specifications subject to change without notice.

For additional information, call 310.542.8561
or e-mail: Orders-EP@eaton.com



Eaton
1000 Eaton Boulevard
Cleveland, OH 44122
United States
Eaton.com

© 2017 Eaton
All Rights Reserved
March, 2017

Eaton is a registered trademark.

All other trademarks are property
of their respective owners.