



www.martekpower.com

# WL, WWL Series

## 400 Hz to DC

- 3-phase Input Linear Power Supply, Single and Dual DC Output
- Low EMI Meets MIL-STD-461A
- High Efficiency
- Power, 48 to 420 Watts

### Specifications

#### Input:

105 to 125 V rms, 380 to 420 Hz, three phase, Delta. Wye configuration available (Option -3).

#### Efficiency:

30% minimum, 50% typical.

#### Line Regulation:

Within 0.1% or 20 mV (whichever is greater) for full rated input change with load constant.

#### Load Regulation:

Within 0.1% or 20 mV (whichever is greater) for load change of no load to full load with line constant.

#### Tracking Accuracy:

Dual-output models. The negative output will track the positive output to within 1% or 100 mV, whichever is greater, for all rated conditions of input voltage, output current, operating temperature, and output voltage adjustment.

#### Pard (Noise and Ripple):

0.02% or 5 mV rms (whichever is greater), 25 mV peak-to-peak at 25 MHz bandwidth.

#### Isolation Voltage:

750 V dc input to output and input to case, 200 V dc output to case.

#### Insulation Resistance:

50 megohms minimum between input and output, input and case, output and case when measured at 50 V dc.

#### Polarity:

Inputs and outputs are isolated. Either positive or negative side of output may be grounded.

#### Temperature Range:

Operating -55°C to +85°C baseplate temperature at full rated power, -55°C to +100°C at 80% rated power. (Derated linearly.) Storage temperature -65°C to +125°C.

#### Temperature Coefficient:

0.015%/°C from -20°C to +80°C baseplate temperature; 0.03%/°C maximum over entire temperature range.

#### Input Transient Protection:

In accordance with MIL-STD-704, Fig. 3, Limit 1 (180 V rms for 0.1 second).

#### Load Transient Response:

Output voltage returns to regulation limits within 100 microseconds after a 50% step change in load current for units supplying 10 A or less; 200 microseconds for units supplying more than 10 A.

#### Load Transient Overshoot:

0.2% or 30 mV (whichever is greater) from nominal voltage set point.

#### Short Circuit Protection:

Completely protected against short circuit or overload of any duration. Output automatically restores to normal after removal of short.

#### Overvoltage Protection:

See Option -1.

#### Remote Error Sensing:

Regulator monitors the voltage directly at the load using extra "sensing" leads and compensates for a dc voltage drop up to 0.5 volt in the load leads. (Single output models only)

#### Electromagnetic Interference:

Units were designed and built to minimize EMI/EMC emissions, and comply with the requirements of MIL-STD-461A by virtue of their topology, construction, and enclosure.

#### Reliability:

The MTBF calculated per MIL-HDBK-217D, under operating conditions of 50°C baseplate temperature, maximum operating input voltage and full rated output power is 164,406 hours for ground benign and 25,633 hours for air inhabited transport environments. With Enhanced Reliability Option (-ER), ground benign is 883,580 hours, air inhabited transport is 94,956 hours. Please consult factory for additional model and environment information.

#### Environment:

Units are encapsulated and hermetically sealed to meet the environmental requirements of MIL-STD-810C including altitude (to 1.3 inches of Hg), acceleration, vibration, shock and temperature altitude cycling.



**MARTEK  
POWER**



**Options**

The following standard options are available on the WL, WWL Series power supplies. Please refer to the option section of this catalog for detailed information.

**Special Connectors:**

A military-type hermetically sealed connector is provided as **Option A** in place of our standard header. (To order, replace "D" in model number with "A," i.e., WL12A-10.)

**Severe Shock, Acceleration and Vibration:**

Special encapsulation, **Option E**, enables all units to withstand 60 g's shock, 50 g's acceleration and 30 g's vibration. (To order, add "E" after "D" in model number, i.e., WL12DE-10.)

**Recentered Input Voltage:**

**Option H** changes input voltage to 208-230 V ac. Some derating may be required. (To order, add "H" after "D" and indicate new input voltage range in parentheses after model number, i.e., WL12DH-10 (208-230).)

**Remote Turn On/Off:**

**Option L** provides isolated terminals to turn outputs on/off with TTL logic signal. (To order, add "L" to character preceding first dash in model number, i.e., WL12DL-10.) WL only.

**Remote Output Adjustment:**

With **Option R**, an adjustment potentiometer can be remotely located to adjust the output voltage. (To order, add "R" after "D" in model number, i.e., WL12DR-10.)

**Internal Overvoltage Protection:**

**Option -1** provides an internal crowbar-type OVP. Input must be recycled to restore output. Option may increase case size. Consult your nearest Abbott sales office. (To order, add "-1" to model number, i.e., WL12D-10-1.)

**WYE Input:**

**Option -3** changes input specifications from 3-phase "DELTA" to 3-phase, 4-wire "WYE." (To order, add "-3" to the end of the model number, i.e., WL12D-10-3.)

**Enhanced Reliability:**

**-ER Option** provides increased reliability by using higher levels of military-grade components. (To order, add "-ER" to the end of the model number, i.e., WL12D-10-ER.)

**9 Standard Single-Output Models**

Output Voltage Range	Output Current (Amps)	Size (See Dwg.)	Weight <sup>2</sup> (Lbs.)	Weight <sup>2</sup> (Kgs.)	Model Number
4.8-5.8	20	12R	6.0	2.7	WL5.3D-20
5.8-6.8	20	12R	6.0	2.7	WL6.3D-20
11-13	10	12R	4.7	2.1	WL12D-10
11-13	20	12N	7.7	3.5	WL12D-20
±11-±13	2	11S	2.4	1.1	WWL12D-2.0

Output Voltage Range	Output Current (Amps)	Size (See Dwg.)	Weight <sup>2</sup> (Lbs.)	Weight <sup>2</sup> (Kgs.)	Model Number
14-16	12	12R	6.0	2.7	WL15D-12
23-25	7.5	12R	6.0	2.7	WL24D-7.5
23-25	15	12N	7.7	3.5	WL24D-15
27-29	10	12N	7.7	3.5	WL28D-10
27-29	15	12N	7.7	3.5	WL28D-15
±14-±16	2	11S	2.4	1.1	WWL15D-2.0

**2 Standard Dual-Output Models<sup>3</sup>**

1. Output voltage is continuously adjustable between the limits shown by means of an externally accessible screwdriver adjustment potentiometer.

Adjustment resolution is 35 millivolts for nominal output voltages of 5.3 to 15 V dc, 60 millivolts for nominal output voltages of 24 to 28 V dc

2. Maximum weight, not including options.

3. Current for each output.

**Model Numbering System**

Product Line Series	Output Voltage Center of Adjustable Range	Header Type	Options	Dash	Output Current Maximum Load
WL	5.3	D		—	20



**Case Drawings**

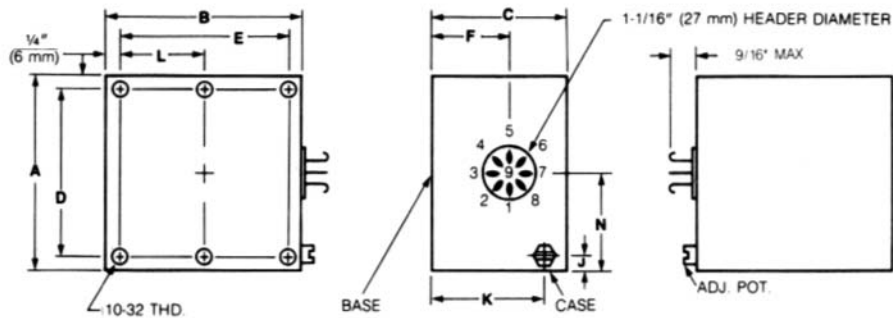

**Dimensions**

Inches  
mm

Case Size	A	B	C	D	E	F	J	K	L	N
11S	3-1/4 83	6 152	2-1/2 64	2.75 69.9	5.50 139.7	1-1/2 38	1/4 6.4	2-1/8 54	2.75 69.9	1-3/8 35
12N	4-3/4 121	8-3/4 222	2-3/4 70	4.25 108.0	8.25 209.6	1-1/2 38	1/4 6.4	2-1/4 57	4.13 104.9	2-3/8 60
12R	4-3/4 121	8 203.2	2-3/4 70	4.25 108.0	7.50 190.5	1-1/2 38	1/4 6.4	2-1/4 57	3.75 95.3	1-7/8 48

**Tolerances:** If English unit is a fraction, ± 1/32 inch, (0.8 mm); if English unit is a decimal, ± 0.015 inch, (0.4 mm).

**Material:** Base — Aluminum 6061-T6, Case — Steel

**Finish:** Black flat lacquer per FED-STD-595, Color 37038.

**Mounting:** 10-32 THD inserts 0.156" min/ 0.250" max depth are provided in in baseplate. 10-32 bolts American Standard, unified national fine series.

slotted studs are supplied with each unit. Metric hardware and inserts available as a special order.

**Pin Designations**

(Standard model, not including options. Consult factory for details.)

WL	WWL	WL	WWL	WL	WWL
1. AC Input	AC Input	4. +Output	+Output	7. -Sense	-Output (DC)
2. AC Input	AC Input	5. +Sense	+Sense	8. Case	-Sense
3. AC Input	AC Input	6. -Output	Common Output (DC)	Ground	
				9. Not Used	Com. Sense