

**SC connector for 1/2.2mm POF**

**1 General**

The FO connector style SC is optimized in particular for applications using standard 1 mm polymer optical fiber acc. IEC 60793-2-40, demanding a fast and easy cable assembly with high reliability, very good optical and mechanical characteristics. The SC connector complies with IEC 61754-4 standard.

**4 Ordering information**

SC connector with dust protection for 1 mm POF with 2.2 mm jacket diameter

**Specification**

with bend protection (black)  
with bend protection (red)  
excluding bend protection

**Part number**

902SS001SC021  
902SS001SC022  
902SS001SC001

Depending on the grip plates ( housings) the connector can be simplex and duplex SC standard or a duplex SCRJ version (Product no. upon request).

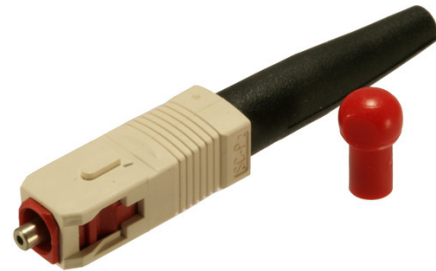

Pic. 1 SC connector with bend protection black

**4 Application**

Due to the good optical features and the easy cable assembly, the SC connector is useable in several applications:

- optical networking
- industrial electronics
- power electronics
- consumer electronics

**3 Drawing**

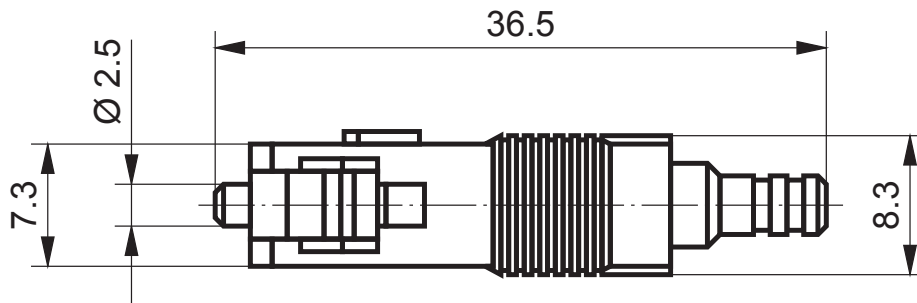

Pic. 2 Dimensions SC connector

## SC connector for 1/2.2mm POF

### 5. Cable assembly \_\_\_\_\_

The following tools and materials are recommended for easy and reliable 1mm POF cable termination with SC connector:

Specification	Part number
Crimping tool hexagonal	910CZ00100008
Fiber stripper	910AB00100001
Polishing disc	910PS0SC00001
Polishing film, grain size 1000	910PB00100001
Polishing film, grain size 4000	910PB00140250



Pic. 4 Crimping tool hexagonal for jacket crimping

#### 5.1 FO cable:

- Remove app. 12 mm of outer jacket 2.2 mm by using the fiber stripper (Pic. 3)

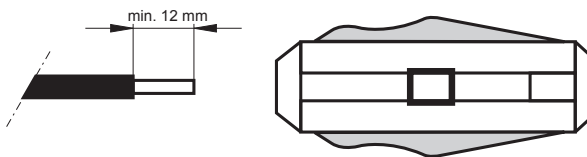

Pic. 3 Stripping dimensions

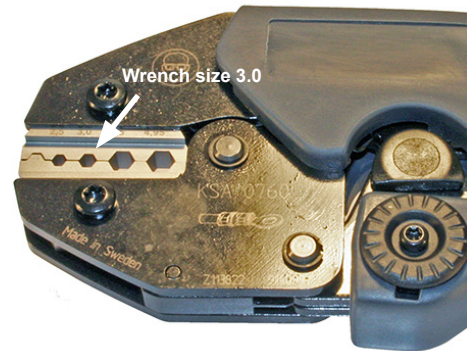

Pic. 5 Crimping cavities of crimping tool hexagonal

#### 5.2 Crimping of 2.2 mm jacket:

- Align the connector anchor (rear end of connector) with the hexagonal cavity, wrench size 3.0 mm (Pic. 4 to 6), of the crimping tool (910CZ00100008) and squeeze the crimping tool handles until they release.
- Alternative to jacket crimping, pasting of jacket is also possible simultaneously with fiber pasting.

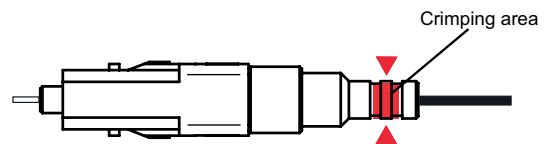

Pic. 6 Crimping area for jacket crimping with crimping tool hexagonal

## SC connector for 1/2.2mm POF

### 5.3 Fiber grinding and polishing:

- Insert the connector fully into the appropriate polish disc.
- Press the tool on the polish paper (grid P1000) and polish the fiber until the fiber is flush with the connector. Use a hard and plain support plate (e.g. glass plate).
- Wipe the connector with a clean tissue.
- Best attenuation values are achieved applying wet polishing.
- Best attenuation values are achieved applying wet polishing, too.

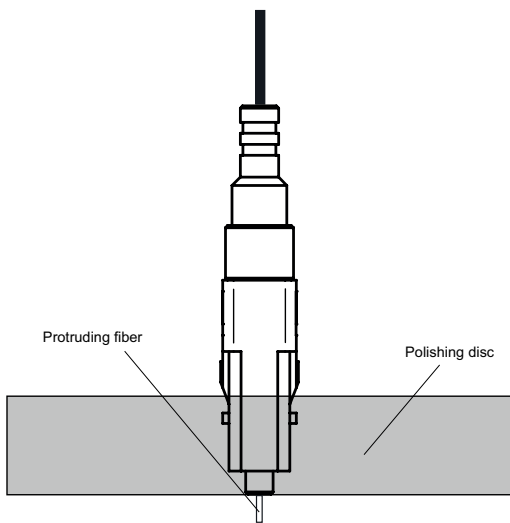

Pic. 7 Polishing disc with SC connector

### 5.4 Connector assembly:

- Push the grip plates over the contact until it snaps in. Please note the keying of the housing (Pic. 8).

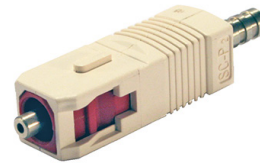

Pic. 8 SC connector (SC contact with grip plate)

## 6 Technical data \_\_\_\_\_

Parameter	Condition	Value	Unit
Material	Ferrule Retainer, Anti-kink sleeve	German silver Plastic	
Insertion loss		≤ 2.0	dB
Retention force cable to connector (ambient temperature)	Fiber pasting	40	N
	Jacket crimping	50	
	Fiber pasting and jacket crimping	80	
Temperature range	Storage and operation	-40 to +85	°C
Mating cycles		≥ 500	Cycles
Protection class	IP20		

The information released by Ratioplast-Optoelectronics GmbH in this data sheet is believed to be accurate and reliable. However, no responsibility is assumed by Ratioplast-Optoelectronics GmbH for its use. Ratioplast-Optoelectronics GmbH reserves the right to change circuitry and specifications at any time without notification to the customer.