

**F-ST connector for POF cable 1/2.2 mm simplex, metal nut**

**1 General** \_\_\_\_\_

The FO connector style F-ST is optimized in particular for applications using standard 1 mm polymer optical fiber demanding a fast and easy cable assembly with high reliability, very good optical and mechanical characteristics.



**2 Application** \_\_\_\_\_

Due to the good optical features and the easy cable assembly, the F-ST connector is useable in several applications:

- Optical networking
- Industrial electronics
- Power electronics
- Consumer electronics

Pic. 1 F-ST connector with metal nut

**4 Ordering information** \_\_\_\_\_

Specification	Part number
Without boot	902SS001ST103
Boot (black)	902SS001ST001-01
Boot (red)	902SS001ST001-02

**3 Technical drawing** \_\_\_\_\_

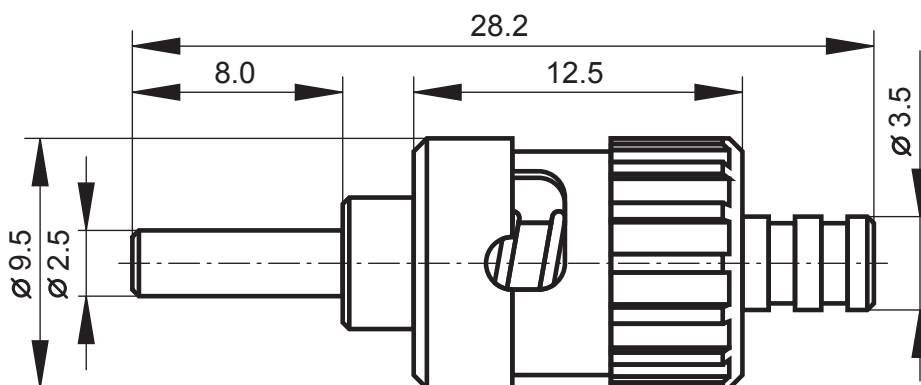

Pic. 2 F-ST connector



**F-ST connector for POF cable 1/2.2 mm simplex, metal nut**

**5. Cable assembly** \_\_\_\_\_

Required tools for assembly of F-ST connector with 1/2.2 mm POF cable:

Specification	Part number
Crimping tool hexagonal	910CZ00100002
Fiber stripper	910AB00100001
Epoxy mix	9102KKPOF0001
Polishing disc	910PS0ST00001
Polishing film, grain size 1000	910PB00100001

**5.1 FO cable:**

- Remove appr. 12 mm of outer jacket 2.2 mm with the fiber stripper (Pic. 3).

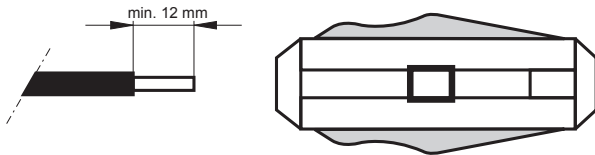

Pic. 3 Fiber stripper

**5.2 Crimping of 2.2 mm jacket:**

- Align the connector anchor (rear end of connector) with the hex. cavity, wrench size 3.0 mm (Pic. 4 and 5), of the crimping tool (910CZ00100002) and squeeze the crimping tool handles until they release.
- Alternative to jacket crimping, pasting of jacket is also possible simultaneously with fiber pasting (Pic. 6).

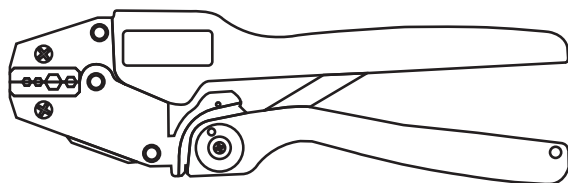

Pic. 4 Crimping tool hexagonal for jacket crimping

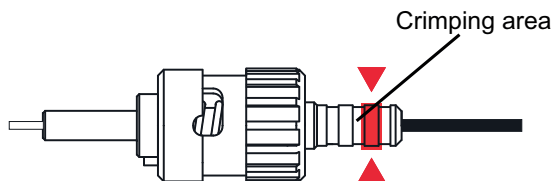

Pic. 5 Crimping area for jacket crimping with crimping tool hexagonal

**5.3 Fiber pasting (alternative):**

- Apply a thin coating of epoxy (9102KK-POF0001) tripped to the fiber. Insert the fiber carefully into the connector up to the stop. Fiber should protrude min. 1 mm out of the connector tip (Pic. 6).

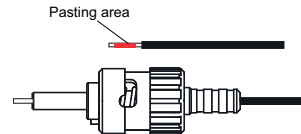

Pic. 6 Pasting area

**5.4 Fiber endface processing:**

- After curing of epoxy insert connector into polishing disc (Pic. 7) and grind off the protruding fiber by using the polish film, grain size 1000 placed on a smooth pad (e.g. glass plate). Press the polishing disc down on the polish film and grind the fiber until the connector is flush with the bottom of the disc.
- Wipe the connector with a clean tissue. Best insertion loss results are achieved by wet grinding.

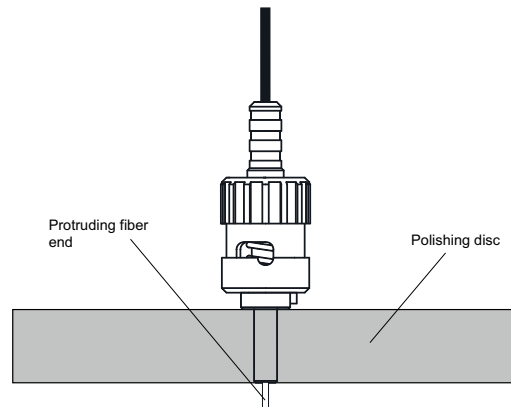

Pic. 7 Polishing disc with connector guidance



**F-ST connector for POF cable 1/2.2 mm simplex, metal nut**

**6 Technical data** \_\_\_\_\_

Parameter	Condition	Value	Unit
Retention force, only fiber pasting	Ambient room temperature	40	N
Retention force, only jacket crimping		50	N
Retention force, fiber pasting and jacket crimping		80	N
Insertion loss		< 4.0	db
Thermal properties	---	-40 to +85	°C

**The information released by Ratioplast-Optoelectronics GmbH in this data sheet is believed to be accurate and reliable. However, no responsibility is assumed by Ratioplast-Optoelectronics GmbH for its use. Ratioplast-Optoelectronics GmbH reserves the right to change circuitry and specifications at any time without notification to the customer.**