

F-ST connector 50-62.5/125µm multimode glass optical fiber cable

1 General _____

The connector style “F-ST” is especially optimised for FO applications with multimode glass optical fiber 50-62.5/125µm, which require quick and easy termination with at the same time very good mechanical and optical characteristics.



Pic. 2 F-ST connector with metal nut

2 Application _____

Due to the very good optical characteristics and easy termination technique, these connectors can be used indifferent applications:

- Optical networks
- Industry electronics
- Power electronics
- Consumer electronics

4 Ordering information _____

F-ST connector for 50-62.5/125µm multimode glass optical fiber, metal ferrule, crimp sleeve and boot

F-ST with plastic nut

3 Dimensioned drawing _____

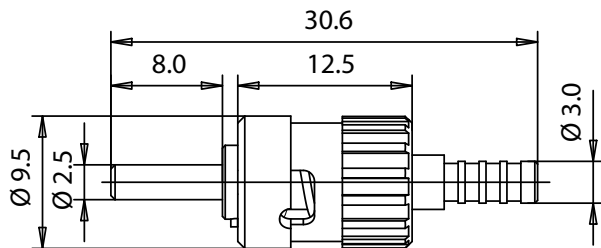

Pic. 1 F-ST connector

Specification

Part number

Boot for 3.0 mm cable

902SS125ST002



F-ST connector 50-62.5/125µm multimode glass optical fiber cable

5 Cable assembly

Required tools for termination of F-ST connector with 50/62.5/125µm fiber optic cable (Pic. 3).

Crimping tool hexagonal	910CZ00100002
Fiber stripper 0.18mm	910AB00118001
Fiber stripper 0.3mm	910AB00130001
Cleaving tool	910FRW0100001
Epoxy mix	9102KKFERTIG1
One-way syringe with needle	910SPRITZ0001
Polishing film 5µm	910PB00105001
Polishing film 0.3µm	910PB00100301
Heat oven	910AO00100001
Polishing disc	910PS0ST00001
Microscope 100x	910MIKRO10002
Adapter	910MIADAST002

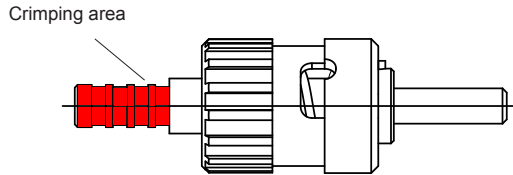

Pic. 3 Crimping area

5.1 FO cable

Strip the cable according to the measures mentioned below (Pic. 4) at minimum 50 mm, then cut down the aramid yarn/kevlar to 6 mm and strip the fiber. First remove the 0.5 mm coating with stripping tool 0.3 mm, then remove the 0.25 coating with the fiber stripper 0.18. Clean off gel residuals with a wipe.

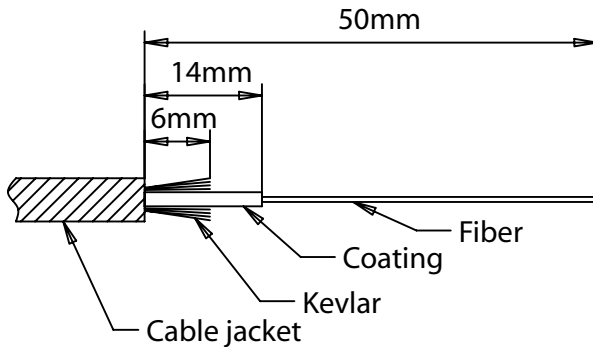

Pic. 4 Stripping dimensions

5.2 Pasting

Compound the epoxy mix and fill it into the one-way syringe. Then fill the F-SMA connector from the cable side with two drops (Ø 2mm) (Pic. 5).

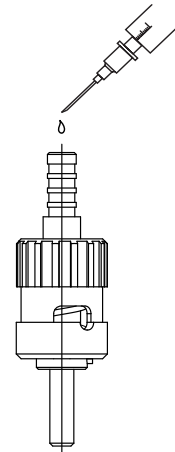

Pic. 5 Filling F-ST connector with adhesive

5.3 Strain relief

Push the crimp sleeve and the bend protection boot upon the cable. After that push the stripped fiber and the cable into the connector up to the end stop. The fiber has to stick out of the ferrule. Afterwards push the crimp sleeve over the kevlar/aramid yarn to the end stop upon the connector (Pic. 6).

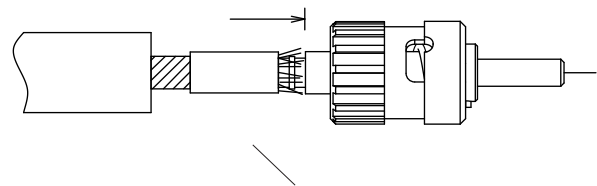

Pic. 6 F-ST connector with crimp sleeve and boot



F-ST connector 50-62.5/125µm multimode glass optical fiber cable

Crimp the sleeve with the allen crimping tool (spanner size 3.3) over the total length and push the bend protection boot onto the sleeve.

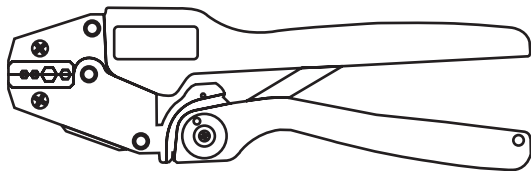

Pic. 7 Crimping tool hexagonal

Have the epoxy in the F-ST contact cured in the heat oven (curing time: min. 1 hour at 70°).

After curing take the connector out off the oven and cleave the overcoming fiber min. 1mm to the end of the ferrule with the cleaving tool (Pic. 8) and break it pulling lightly.

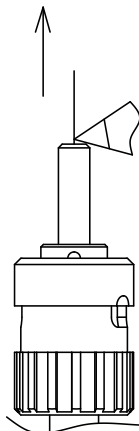

Pic. 8 Cleaving fiber

5.4 Fiber endface processing

Grind off carefully the protruding fiber end with polishing film 5 µm with low pressure (Pic. 9).

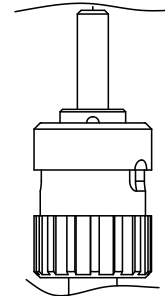

Pic. 9 Fiber grinding

Insert the F-SMA connector into the polishing disc (Pic. 10) and polish it with polishing film 0.3 µm on hard base (glass plate) for flat polish.

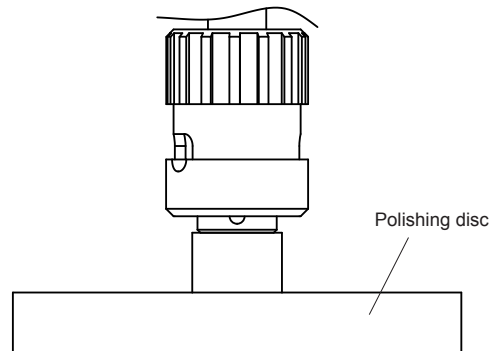

Pic. 10 F-ST connector with polishing disc

- Check the quality of the fiber surface with the microscope
- Repeat polishing if the surface is not free of scratches in the core area.
- After polishing please wipe off the polishing residuals

The information released by Ratioplast-Optoelectronics GmbH in this data sheet is believed to be accurate and reliable. However, no responsibility is assumed by Ratioplast-Optoelectronics GmbH for its use. Ratioplast-Optoelectronics GmbH reserves the right to change circuitry and specifications at any time without notification to the customer.