

**HFBR metal connector for 1.0 / 1.5 / 2.3 mm POF\*- MOST**

**1 Order information** \_\_\_\_\_

<i>Item</i>	<i>Product number</i>
HFBR connector	902SS155H4502



Fig. 1 HFBR connector

**2 Technical drawing** \_\_\_\_\_

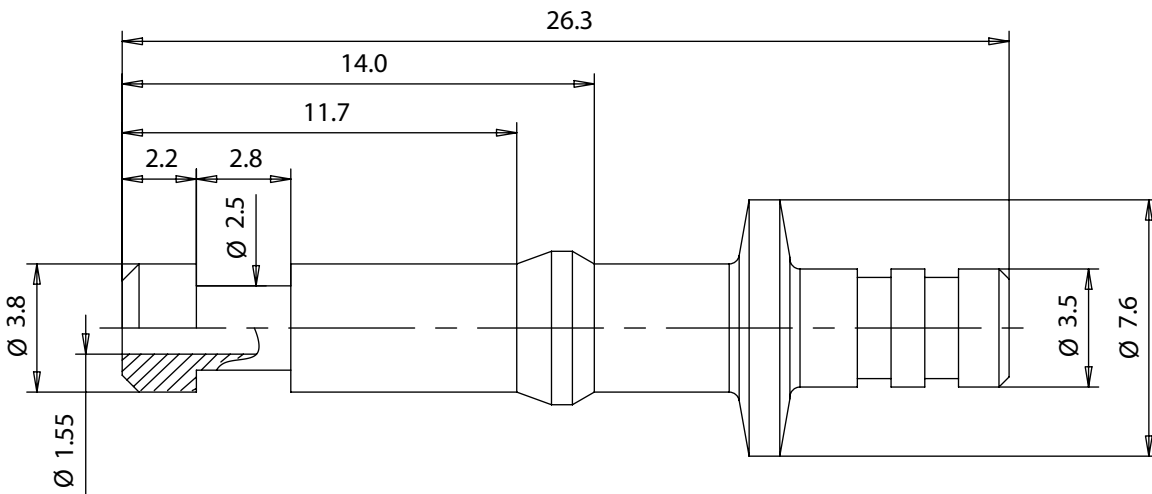

Fig. 2 Drawing of HFBR connector

**3 Assembly** \_\_\_\_\_

Tools required for assembling the HFBR connectors with 2.3 mm POF\*-MOST.

<i>Item</i>	<i>Product number</i>
4-pin crimping tool	910 CZ 001 00 004
Stripping tool	910 AZ 001 00 PA1
Polishing disc	910 PS H45 01 001
Polishing paper, graining size 1000	910 PB 001 00 001
Polishing paper, graining size 4000	910 PB 001 40 250



## HFBR Metal connector for 1.0 / 1.5 / 2.3 mm POF\*- MOST

### 3.1 F/O cable

- Strip the 2.3mm POF\*-MOST jacket to at least 10mm for the HFBR connector (see figure 3). Do not strip the 1.5mm inner jacket.

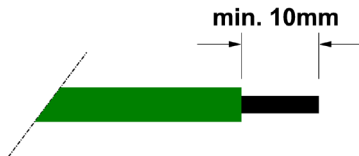

Fig. 3 Example of MOST fiber

### 3.2 Crimping the fiber

- The data sheet for crimping tool T10 CZ 001 00 004 explains how the crimping tool works and how to adjust the crimping dimension and locator for the connector to be crimped
- Push the stripped fibre as far as possible into the connector sleeve (see figure 4) so that it protrudes approx. 1 mm from the tip of the connector

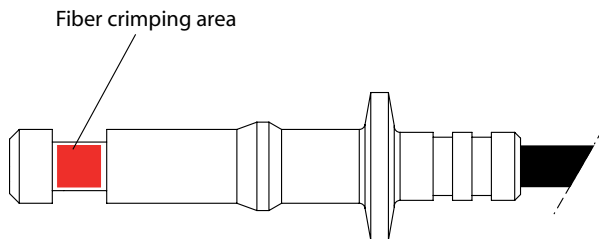

Fig. 4 Fiber crimping area

- Insert the connector together with the fiber optic cable as far as possible into the crimping opening of the crimping tool (910 CZ 001 00 004) (see figures 5-6) while applying gentle pressure to the fiber optic cable and connector; close the tool until you hear it disengage.

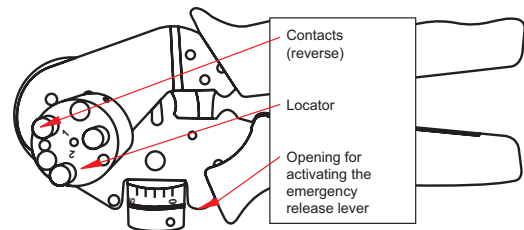

Fig. 5 Locator side of the crimping tool (reverse)

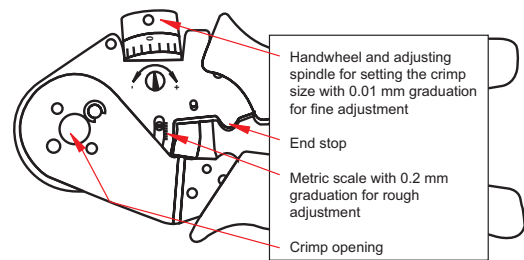

Fig. 6 Crimp opening and scale in the crimping tool (front)

### 3.3 Finishing fiber end surface:

- Insert the connector into the polishing disc (910 PS H45 01 001) as shown in figure 7 and, working on a smooth surface (such as a sheet of glass), use grade 1000 polishing paper to grind off the protruding fiber and polish it with grade 4000 polishing paper
- Wipe away any residue remaining after grinding. The best optical attenuation values are achieved when a wet grinding method is used

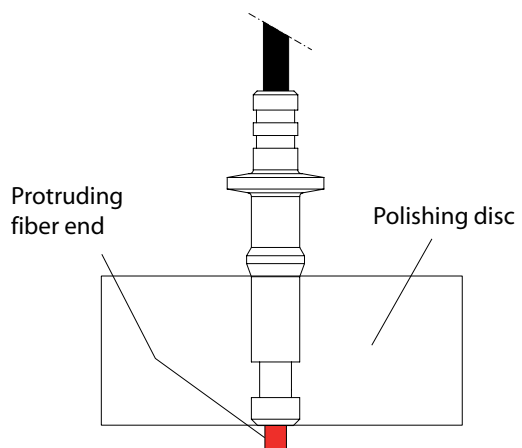

Fig. 7 Polishing disc with guide for connector sleeve

\* POF = Polymer Optical Fiber

The information released by Ratioplast-Optoelectronics GmbH in this data sheet is believed to be accurate and reliable. However, no responsibility is assumed by Ratioplast-Optoelectronics GmbH for its use. Ratioplast-Optoelectronics GmbH reserves the right to change circuitry and specifications at any time without notification to the customer.