

F-SMA connector for 200/230µm fiber optic cable

1 General

The connector style "F-SMA" is especially optimised for FO applications, which require quick and easy termination with at the same time very good mechanical and optical characteristics.

2 Application

Due to the very good optical characteristics and easy termination technique, these connectors can be used indifferent applications:

- Optical networks
- Industry electronics
- Power electronics
- Consumer electronics

3 Dimensioned drawing

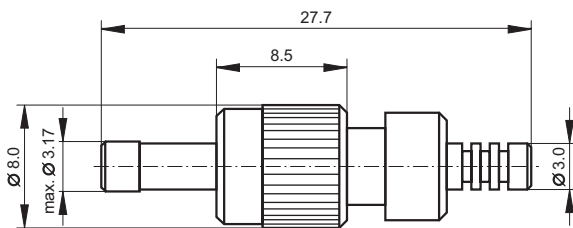

Pic. 3 F-SMA connector with knurled nut

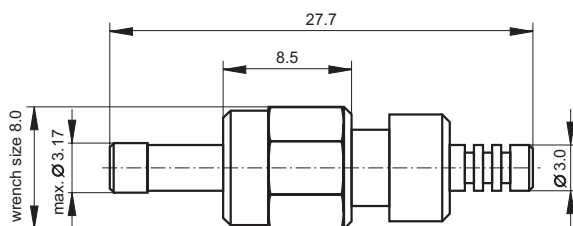

Pic. 4 F-SMA connector with hexagonal nut



Pic. 1 F-SMA connector with knurled nut



Pic. 2 F-SMA connector with hexagonal nut

4 Ordering information

F-SMA Steckverbinder for 230 µm fiber with metal ferrule, crimp sleeve and bend protection boot

F-SMA with knurled nut for cable Ø 3mm:

Specification	Part number
Boot (black)	902SS230SM001
Boot (red)	902SS230SM003

F-SMA with hexagonal nut for cable Ø 3mm:

Specification	Part number
Boot (black)	902SS230SM002
Boot (red)	902SS230SM004

F-SMA with knurled nut for cable Ø 5mm:

Specification	Part number
Boot (black)	902SS230SM051

F-SMA with hexagonal nut for cable Ø 5mm:

Specification	Part number
Boot (black)	902SS230SM052

F-SMA connector for 200/230µm fiber optic cable

5 Termination

Required tools for termination of F-SMA connector (Pic. 5) with 200/230 µm fiber optic cable:

Crimping tool hexagonal	910CZ00100002
Fiber stripper 0.3mm	910AB00130001
Cleaving tool	910FRW0100001
Epoxy mix	9102KKFERTIG1
One-way syringe with needle	910SPRITZ0001
Polishing film 5µm	910PB00105001
Polishing film 1µm	910PB00101001
Heat oven	910AO00100001
Polishing disc	910PSSM00001
Microscope 100x	910MIKRO10002
Adapter	910MIADASM002

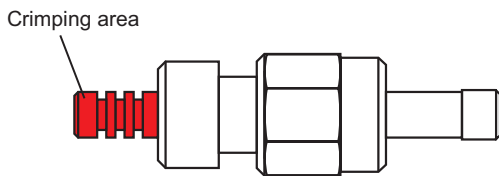

Pic. 5 Crimping area

5.1 FO cable

Strip the cable according to the measures mentioned below (Pic. 6) at minimum 50 mm, then cut down the aramid yarn/kevlar to 6 mm and strip the fiber. First remove the 0.5mm coating with stripping tool 0.3mm. Clean off gel residuals with a wipe.

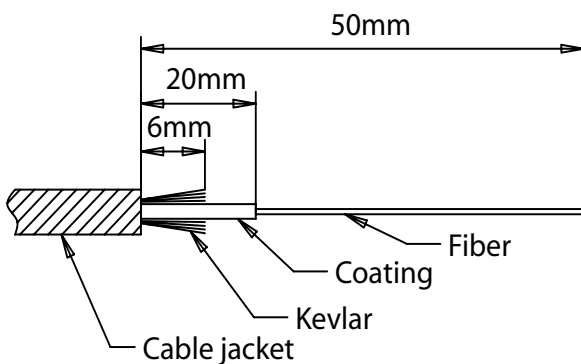

Pic. 6 Stripping dimensions

5.2 Adherence

Please compound the epoxy mix and fill it into the one-way syringe. Then fill the F-SMA connector from the cable side with two drops (Ø 2mm) (Pic. 7).

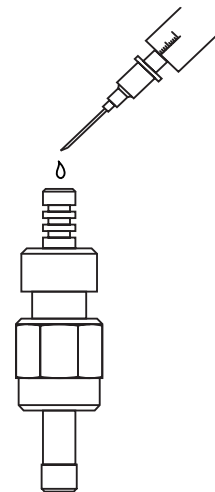

Pic. 7 Filling the F-SMA connector with epoxy

5.2 Strain relief

Push the crimp sleeve and the bend protection boot upon the cable. After that push the stripped fiber and the cable into the connector up to the end stop. The fiber has to stick out of the ferrule. Afterwards push the crimp sleeve over the kevlar/aramid yarn to the end stop upon the connector (Pic. 8).

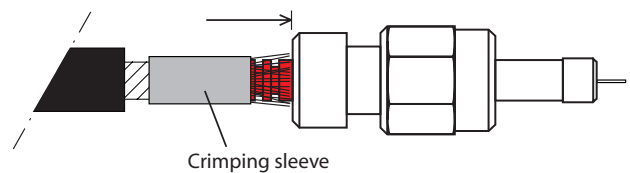

Pic. 8 F-SMA connector with crimping sleeve and boot



F-SMA connector for 200/230µm fiber optic cable

Crimp the sleeve with the allen crimping tool (spanner size 3.3) over the total length and push the bend protection boot onto the sleeve.

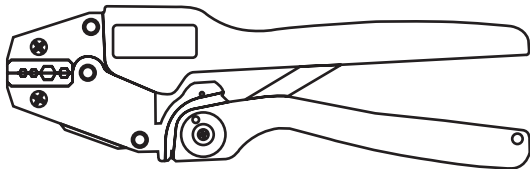

Pic. 9 Crimping tool hexagonal

Have the epoxy in the F-SMA contact cured in the heat oven (curing time: min. 1 hour at 70°).

After curing take the connector out off the oven and cleave the overcomig fiber min. 1mm to the end of the ferrule with the cleaving tool (Pic. 10) and break it pulling lightly.

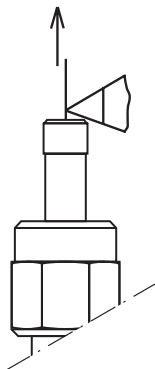

Pic. 10 Cleaving of protruding fiber

5.3 Connector interface treatment

Grind off carefully the prodtruding fiber end with polishing film 5µm with low pressure (Pic. 11).

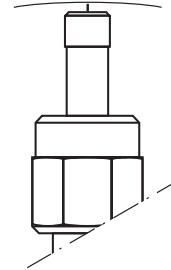

Pic. 11 Polishing the fiber with polishing film

Insert the F-SMA connector into the polishing disc (Pic. 12) and polish it with polishing film 1µm on hard base (glass plate) for flat polish.

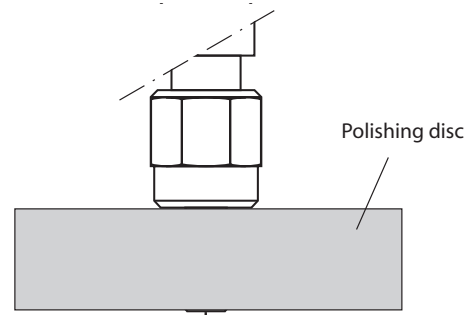

Pic. 12 F-SMA connector with polishing disc

- Check the quality of the fiber surface with the microscope
- Repeat polishing if the surface is not free of scratches in the core area.
- After polishing please wipe off the polishing residuals

The information released by Ratioplast-Optoelectronics GmbH in this data sheet is believed to be accurate and reliable. However, no responsibility is assumed by Ratioplast-Optoelectronics GmbH for its use. Ratioplast-Optoelectronics GmbH reserves the right to change circuitry and specifications at any time without notification to the customer.