

SCRJ-Transceiver 1300nm 125MBit/s

1 General

The SCRJ Transceiver is designed to suit applications with 50/125µm graded index optical fiber. A fast 1310nm LED with high optical power output and a high bandwidth optical receiver makes this transceiver a good choice for fiber optic systems using 50 or 62.5µm optical fiber.

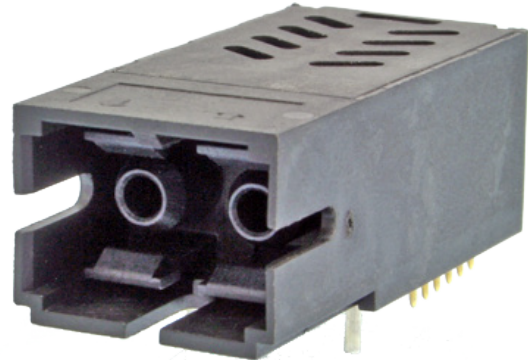

Fig. 1 SCRJ Transceiver

2 Application

Due to the max. data rate of 125MBit/s, the good optical properties and the easy optical fiber termination, the transceiver may be used in many applications:

- Optical networks
- Fast-Ethernet
- Industrial electronics
- Power electronics
- Consumer electronics

5 Features

- 1310nm Wavelength
- -19dBm optical power output (50/125µm GI)
- -30dBm receiver sensitivity
- 125MBit/s
- +3.3V power supply
- PECL in-/outputs
- Signal Detect (SD) output
- I²C Management Interface
- Conductive plastic case

3 Ordering Information

Specification	Part Number
1310nm SCRJ	905TR130SR001

4 Drawings

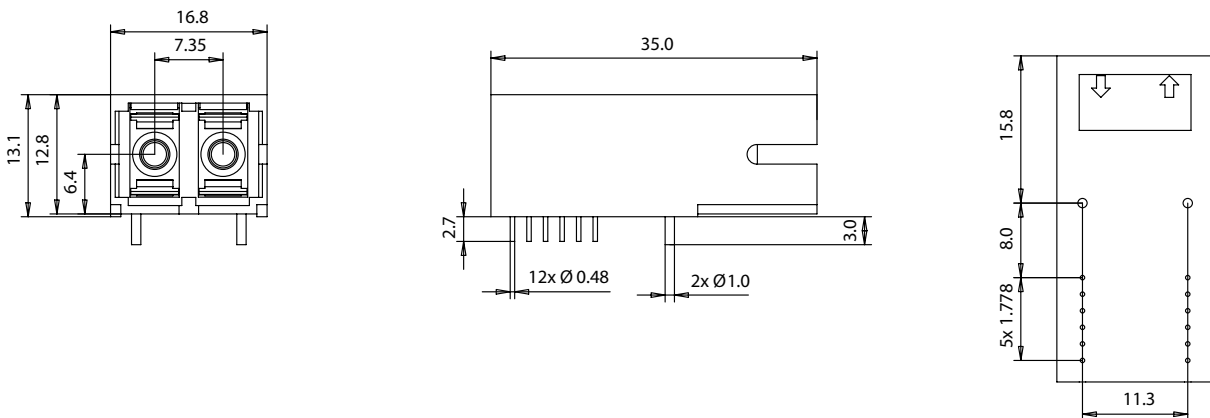

Fig. 2 drawing



SCRJ-Transceiver 1300nm 125MBit/s

6 Maximum Ratings _____

Stresses beyond those listed under 'Maximum Ratings' may cause permanent damage to the device. Listed values are stress limits only and functional operation of the device at these conditions is not recommended. Exposure to maximum rating conditions for extended periods may affect the device reliability.

Parameter	Value	Unit
operating temperature	-40...+80	°C
storage temperature	-40...+100	°C
power supply	4	V
input voltage	-0.5..VCC	V
differential input voltage	1.4	V
output current	50	mA

7 Technical Data _____

Parameter	Value	Unit
power supply	3.3	V
transmitter current consumption	90	mA
receiver current consumption	70	mA
tr, tf, optical output	2.5	ns
fiber coupled power P _{out} into 50/125µm GI FO	12	µW
wavelength λ	1310	nm
spectral bandwidth Δλ	25	nm
reciever sensitivity P _{in min}	1	µW
tr, tf data output	2.2	ns
signal-detect hysteresis	2.5	dB
signal jitter max	4.2	ns p-p

8 Pin Assignment _____

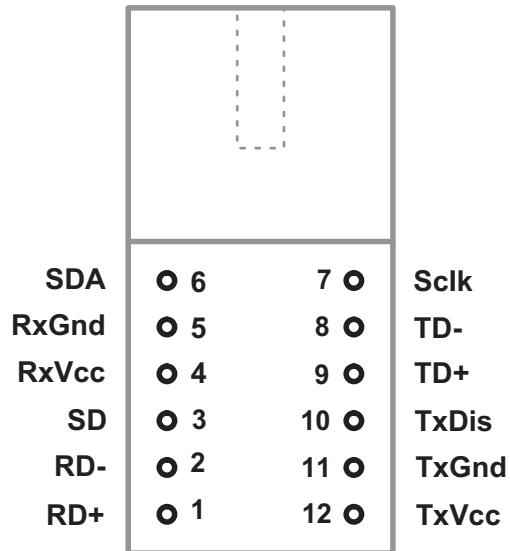

Fig. 3 Pin assignment

PIN	Name	Function
1	RD+	receive data out+
2	RD-	receive data out-
3	SD	signal detect
4	RxVcc	+3.3V receiver
5	RxGnd	Gnd receiver
6	SDA	I ² C serial data IO
7	Sclk	I ² C serial clock input
8	TD-	transmit data in-
9	TD+	transmit data in+
10	TxDis	disable transmitter input
11	TxGnd	transmitter Gnd
12	TxVcc	+3.3V transmitter



SCRJ-Transceiver 1300nm 125MBit/s

9 Application hints

The transceiver is designed for applications using standard 50/125µm GI-fiber. Max. link length is 2500m.

10 External Circuitry

To receive an optimum performance of the transceiver a good power supply decoupling and signal line termination as shown in pic.4 is mandatory. Place decoupling capacitors and termination resistors as close as possible to the inputs. Resistor values shown in table below.

Ferrite
 Impedance typ. 120Ω @ 100MHz
 DC resistor max 0.15Ω @ 200mA

VCC = 3.3V
 Ra = 82 Ohm
 Rb = 130 Ohm

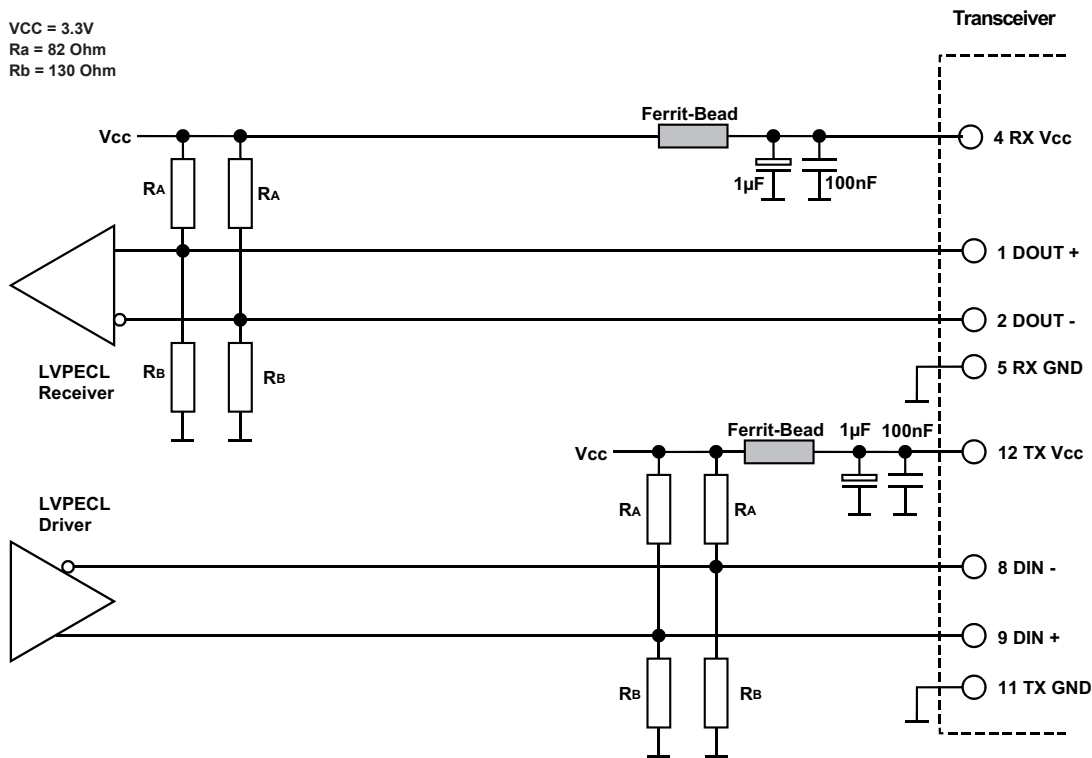

Fig. 4 Parallel Termination

11 Block diagram

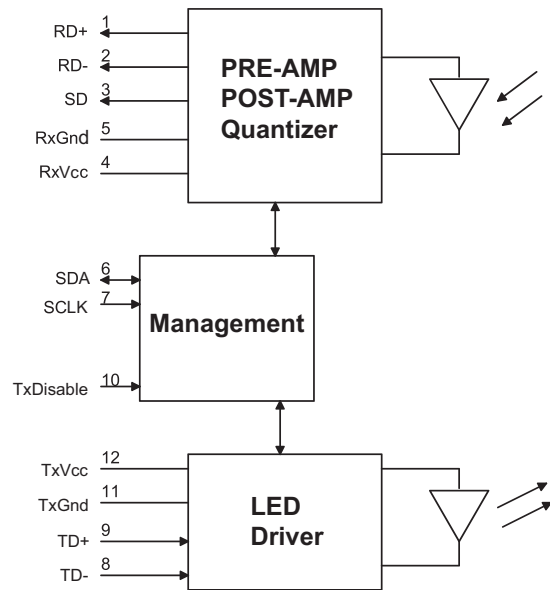

Fig. 5 Block diagram



SCRJ-Transceiver 1300nm 125MBit/s

12 I²C Address _____

Serial Address = A0 (HEX)			
Address (HEX)	Field Size (Byte)	Name	Description
00-5F	96	Serial ID	GP NVRAM; R/W under valid OEM password
60-7F	32	Vendor Specific	Vendor specific EEPROM
80-FF	128	Reserved	Reserved for future use

Serial Address = A2 (HEX)			
Address (HEX)	Field Size (Byte)	Name	Description
00-27	40	Alarm and Warning Threshold	High/Low limits for warning and alarms
28-37	16	Reserved	Reserved - do not write; reads undefined
38-5B	36	Calibration Constants	Numerical constants for external calibration
5C-5E	3	Reserved	Reserved - do not write; reads undefined
5F	1	Checksum	GP NVRAM; R/W under valid OEM password
60-69	10	Analog Data	Real time analog parameter data
6A-6D	4	Reserved	Reserved - do not write; reads undefined
6E	1	Control/Status Bits	Control and status bits
6F	1	Reserved	Reserved - do not write; reads undefined
70-71	2	Alarm Flags	Alarm status bits; read only
72-73	2	Reserved	Reserved - do not write; reads undeined
74-75	2	Warning Flags	Warning status bits; read only
76-77	2	Reserved	Reserved - do not write; reads undefined
78-7B	4	OEMPW	OEM password entry field
7C-7F	4	Reserved	Reserved - do not write; reads undefined
80-F7	120	User Scatchpad	User writeable EEPROM
F8-F9	2	Reserved	Reserved - do not write; reads undefined
FA	1	USRPWSET	User passwort setting; read/write using and pw; returns zero otherwise
FB	1	USRPW	Entry field for user password
FC-FD	2	POH	Power-On hour meter result; read only
FE	1	Data Ready Flags	Data ready bits for each measured parameter; read only
FF	1	User Control	End-user control and status bits



SCRJ-Transceiver 1300nm 125MBit/s

12 I²C Address (continued) _____

Serial Address = A4 (HEX)			
Address (HEX)	Field Size (Byte)	Name	Description
00-3F	64	APCLUTn	APC look up table
40-7F	64	MODLUTn	VMOD look up table
80-BF	64	IFLTUT	Bias current fault threshold look up table
C0-FF	64	EOLLUTn	Bias current high alarm look up table

Serial Address = A6 (HEX)			
Address (HEX)	Field Size (Byte)	Name	Description
00	1	OEMCFG0	Control and status bits
01	1	OEMCFG1	Control and status bits
02	1	OEMCFG2	Control and status bits
03	1	APCSET0	APC setpoint 0
04	1	APCSET1	APC setpoint 1
05	1	APCSET2	APC setpoint 2
06	1	MODSET	DAC setpoint
07	1	IBFLT	Bias current fault comparator threshold
08	1	TXPFLT	TX power fault threshold
09	1	LOSFLT	RX loss fault comparator threshold
0A	1	FLTTMR	Fault comparator masking interval timer setting
0B	1	FLTMSK	Fault source mask bits
0C-0F	2	OEMPWSET	OEM area access password
10	1	OEMCAL0	OEM calibration register 0
11	1	OEMCAL1	OEM calibration register 1
12	1	LUTINDX	Look up table index read back
13	1	Reserved	Reserved for future use
14	1	APCDAC	Reads back current APC DAC setting
15	1	MODDAC	Reads backcurrent MOD setting
16	1	OEMREAD	Reads back OEM calibration data
17	1	LOSFLTn	LOS de-assert threshold
18	1	RXPOT	RX-Pot tab selection
19	1	OEMCFG4	Start selection bits



SCRJ-Transceiver 1300nm 125MBit/s

12 I²C Address (continued) _____

Serial Address = A6 (HEX)			
Address (HEX)	Field Size (Byte)	Name	Description
1A-1F	6	Reserved	Reserved for future use
20-27	8	POHDATA	Power-On hour meter scratchpad
28-47	32	RXLUT	RX power calibration look up table
48-49	2	Reserved	Reserved for future use
4A-57	18	CAL	Internal calibration slope and offset data
59-7D	37	Reserved	Reserved for future use
7E-FD	128	SCRATCH	Scratchpad area
FE	1	MFG_ID	42
FF	1	DEV_ID	Device and die revision

13 I²C Interface _____

I ² Interface			
Parameter	Symbol	Value	Unit
Low output voltage	V _{CL}	0.8	V (max.)
High input voltage	V _{IH}	2.1	V (min.)
Clock period	t ₁	2.5	µs (min.)
Data IN setup time	t ₂	100	ns (min.)
Data OUT stable	t ₃	300	ns (min.)
Data low to Clk low	t ₄	100	ns (min.)
Data high to Clk high	t ₅	100	ns (min.)

14 I²C Timing _____

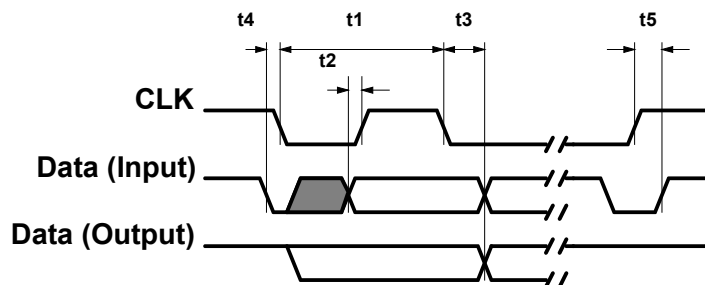

The information released by Ratioplast-Optoelectronics GmbH in this data sheet is believed to be accurate and reliable. However, no responsibility is assumed by Ratioplast-Optoelectronics GmbH for its use. Ratioplast-Optoelectronics GmbH reserves the right to change circuitry and specifications at any time without notification to the customer.