

Polishing Jig for SC Connectors

1 General

Assembled Plastic Optical Fibers have to be polished to achieve optimal attenuation values. The fibers are polished until the fiber end face is flush with the assembled connector. A hard and plain support plate (e. g. glass plate), an abrasive and a polishing jig is used for an appropriate fiber end face treatment. This polishing jig is suitable for F-05 connectors compatible with Toshiba TOSLINK Series.



Pic. 1 Polishing jig

2 Ordering Information

Type	Order number
Polishing jig for SC connectors	910PS0SC00001

3 Operating instruction

Insert the connector fully into the polishing jig. Press the tool on the polish paper (grid P1000) and polish the fiber until the fiber is flush with the connector. Use a hard and plain support plate (e.g. glass plate).

5 Dimensioned drawing

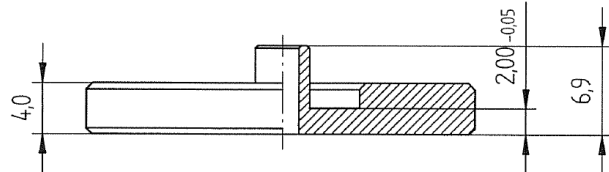

4 Technical Data

Material:	Stainless steel
Dimensions:	d = 30mm
Jig height:	4.0mm
Weight:	21 g

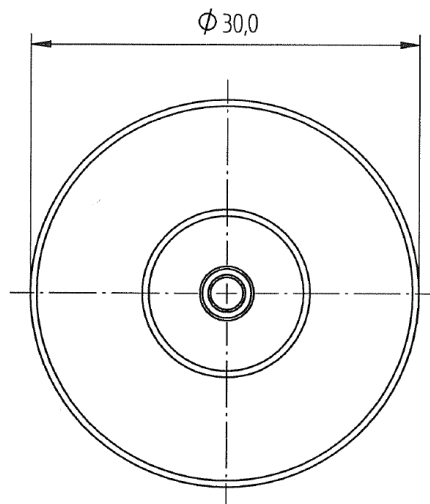

Pic. 2 Drawing

The information released by Ratioplast-Optoelectronics GmbH in this data sheet is believed to be accurate and reliable. However, no responsibility is assumed by Ratioplast-Optoelectronics GmbH for its use. Ratioplast-Optoelectronics GmbH reserves the right to change circuitry and specifications at any time without notification to the customer.