

**Metallized Polypropylene (PP) - Capacitors for DC-Link Applications.**  
**Capacitances from 140  $\mu\text{F}$  to 8250  $\mu\text{F}$ . Rated Voltages from 450 VDC to 1500 VDC.**

## Special Features

- Very high volume/capacitance ratio
- Self-healing, internal safety disconnecter
- Safe contact configurations by screwable plates
- Dry construction without electrolyte or oil
- Very low dissipation factor
- Negative capacitance change versus temperature
- Very low dielectric absorption
- According to RoHS 2015/863/EU
- Customer-specific tabs, capacitances or voltages on request
- 105° C version on request

## Typical Applications

As intermediate circuit capacitor e. g. in high power converter technology

## Construction

### Dielectric:

Polypropylene (PP) film

### Capacitor electrodes:

Vacuum-deposited

### Internal construction:

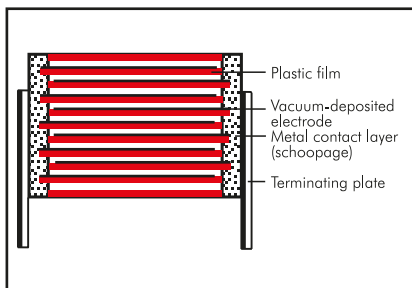

### Encapsulation:

Solvent resistant, flame-retardant plastic case with PU seal

### Terminations:

Tinned plates, customized plate configurations are possible.

### Marking:

Colour: Black. Marking: Gold.

## Electrical Data

**Capacitance range:** 140  $\mu\text{F}$  to 8250  $\mu\text{F}$

### Rated voltages:

450 VDC, 900 VDC, 1500 VDC

**Capacitance tolerance:**  $\pm 10\%$

### Operating temperature:

$-55^\circ\text{C}$  to  $+85^\circ\text{C}$  ( $+105^\circ\text{C}$  on request)

### Insulation resistance at $+20^\circ\text{C}$ :

$\geq 30\,000$  sec ( $\text{M}\Omega \times \mu\text{F}$ )

Measuring voltage: 100 V/1 min.

**Self-inductance:**  $\leq 50$  nH depending on tab configuration

**ESR at  $+20^\circ\text{C}$ :** See General Data.

**Test voltage:**  $1.5 U_r$ , 10 sec

**Dielectric absorption:** 0.05 %

### Voltage derating:

A derating factor of 1.35% per K must be applied from  $+70^\circ\text{C}$  for AC currents ( $I_{\text{rms}}$ )

### Reliability:

Operational life  $> 100\,000$  hours at  $70^\circ\text{C}$  hot spot

Failure rate  $< 50$  fit (hot spot  $\leq 70^\circ\text{C}$ )

### Specific dissipation:

See General Data.

**Standards:** in accordance with IEC 61071

## Mounting Recommendation

Excessive mechanical strain, e. g. pressure or shock onto the capacitor body, is to be avoided during mounting and usage of the capacitors. When fixing the capacitor the screw torque is to be limited to max. 5 Nm.

## Packing

Transportation-safe packing in cardboard boxes.

For further details and graphs please refer to Technical Information.

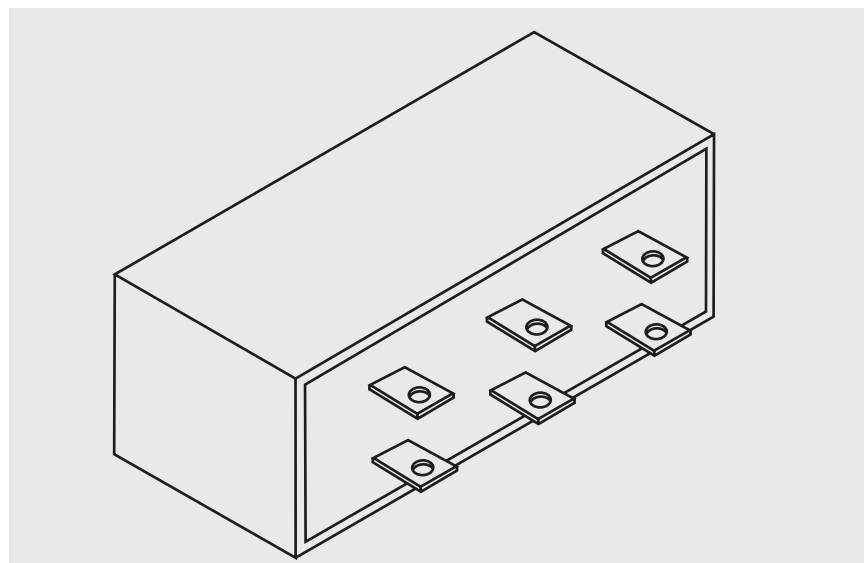

## Continuation

### General Data

$U_R$	$C_N$	$E_N$ $W_S$	Size (mm)			$I_{rms}$ (max.)* A	$\hat{I}^*$ kA	$I_S^*$ kA	ESR (1 kHz)* mΩ	$R_{th}^*$ K/W	Approx. weight g	Part number
			W	H	L							
450 VDC	1440 μF	146	84	66	179	100	4.6	18.6	0.3	2.8	1220	DCHCH07144JB00KS00
	2400 "	243	84	66	291	170	7.7	30.9	0.2	1.8	1985	DCHCH07240JH00KS00
	3000 "	304	107	91	179	120	6.7	26.7	0.3	2.0	2145	DCHCH07300JC00KS00
	4950 "	501	130	114	179	140	8.7	34.9	0.3	1.5	3265	DCHCH07495JE00KS00
	5000 "	506	107	91	291	190	11.1	44.5	0.2	1.3	3485	DCHCH07500JI00KS00
	8250 "	835	130	114	291	210	14.5	58.1	0.2	1.1	5305	DCHCH07825JJ00KS00
900 VDC	450 μF	182	84	66	179	90	2.2	8.8	0.5	2.8	1220	DCHCN06450JB00KS00
	750 "	304	84	66	291	140	3.7	14.6	0.3	1.8	1985	DCHCN06750JH00KS00
	940 "	381	107	91	179	100	2.9	11.6	0.5	2.0	2145	DCHCN06940JC00KS00
	1500 "	608	130	114	179	110	3.5	14.1	0.5	1.5	3265	DCHCN07150JE00KS00
	1560 "	632	107	91	291	160	4.8	19.3	0.3	1.3	3485	DCHCN07156JI00KS00
	2600 "	1053	130	114	291	180	6.1	24.4	0.3	1.1	5305	DCHCN07260JJ00KS00
1500 VDC	140 μF	158	84	66	179	60	1.2	4.9	0.9	2.8	1220	DCHCS06140JB00KS00
	230 "	259	84	66	291	100	2.0	8.1	0.6	1.8	1985	DCHCS06230JH00KS00
	280 "	315	107	91	179	80	1.5	6.1	0.8	2.0	2145	DCHCS06280JC00KS00
	460 "	518	130	114	179	90	1.8	7.3	0.8	1.5	3265	DCHCS06460JE00KS00
	470 "	529	107	91	291	130	2.5	10.2	0.5	1.3	3485	DCHCS06470JI00KS00
	790 "	889	130	114	291	150	3.1	12.5	0.4	1.1	5305	DCHCS06790JJ00KS00

\* General guide

Customer-specific tabs, capacitances or voltages on request

External wiring:

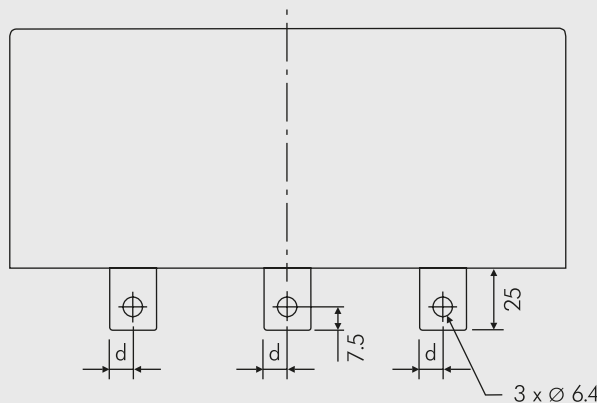
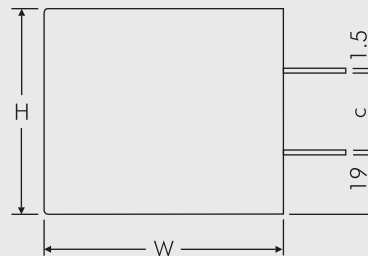
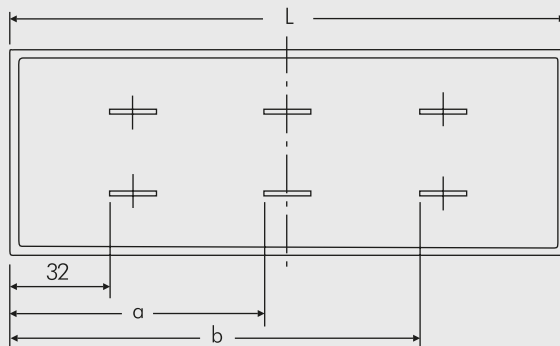
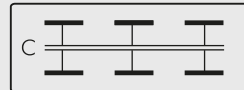

W	H	L	a	b	c	d
84	66	179	82	132	25	7.5
107	91	179	82	132	50	7.5
130	114	179	82	132	73	7.5
84	66	291	135.5	239	25	10
107	91	291	135.5	239	50	10
130	114	291	135.5	239	73	10

Dims. in mm. Case tolerances: general tolerances in accordance with ISO 2768-1 C (approximate)

Rights reserved to amend design data without prior notification.



A WIMA part number consists of 18 digits and is composed as follows:

- Field 1 - 4: Type description
- Field 5 - 6: Rated voltage
- Field 7 - 10: Capacitance
- Field 11 - 12: Size and PCM
- Field 13 - 14: Version code (e.g. Snubber versions)
- Field 15: Capacitance tolerance
- Field 16: Packing
- Field 17 - 18: Pin length (untaped)

1	2	3	4	5	6	7	8	9	10	11	12	13	14	15	16	17	18
M	K	S	2	C	0	2	1	0	0	1	A	0	0	M	S	S	D
MKS 2				63 VDC		0.01 µF			2.5x6.5x7.2			-		20%	bulk	6 -2	

<p><b>Type description:</b></p> <p>SMD-PET = SMDT          SMD-PEN = SMDN          SMD-PPS = SMDI          FKP 02 = FKPO          MKS 02 = MKSO          FKS 2 = FKS2          FKP 2 = FKP2          FKS 3 = FKS3          FKP 3 = FKP 3          MKS 2 = MKS2          MKP 2 = MKP2          MKS 4 = MKS4          MKP 4 = MKP4          MKP 10 = MKP1          FKP 4 = FKP4          FKP 1 = FKP1          MKP-X2 = MKX2          MKP-X1 R = MKX1          MKP-Y2 = MKY2          MKP 4F = MKPF          Snubber MKP = SNMP          Snubber FKP = SNFP          GTO MKP = GTOM          DC-LINK MKP 4 = DCP4          DC-LINK MKP 6 = DCP6          DC-LINK HC = DCHC</p>	<p><b>Rated voltage:</b></p> <p>50 VDC = B0          63 VDC = C0          100 VDC = D0          250 VDC = F0          400 VDC = G0          450 VDC = H0          520 VDC = H2          600 VDC = I0          630 VDC = J0          700 VDC = K0          800 VDC = L0          850 VDC = M0          900 VDC = N0          1000 VDC = O1          1100 VDC = P0          1200 VDC = Q0          1250 VDC = R0          1500 VDC = S0          1600 VDC = T0          1700 VDC = TA          2000 VDC = U0          2500 VDC = V0          3000 VDC = W0          4000 VDC = X0          6000 VDC = Y0          230 VAC = 3Y          275 VAC = 1W          300 VAC = 2W          305 VAC = AW          350 VAC = BW          440 VAC = 4W          ...</p>	<p><b>Capacitance:</b></p> <p>22 pF = 0022          47 pF = 0047          100 pF = 0100          150 pF = 0150          220 pF = 0220          330 pF = 0330          470 pF = 0470          680 pF = 0680          1000 pF = 1100          1500 pF = 1150          2200 pF = 1220          3300 pF = 1330          4700 pF = 1470          6800 pF = 1680          0.01 µF = 2100          0.022 µF = 2220          0.047 µF = 2470          0.1 µF = 3100          0.22 µF = 3220          0.47 µF = 3470          1 µF = 4100          2.2 µF = 4220          4.7 µF = 4470          10 µF = 5100          22 µF = 5220          47 µF = 5470          100 µF = 6100          220 µF = 6220          1000 µF = 7100          1500 µF = 7150          ...</p>	<p><b>Size:</b></p> <p>4.8x3.3x3 Size 1812 = KA          4.8x3.3x4 Size 1812 = KB          5.7x5.1x3.5 Size 2220 = QA          5.7x5.1x4.5 Size 2220 = QB          7.2x6.1x3 Size 2824 = TA          7.2x6.1x5 Size 2824 = TB          10.2x7.6x5 Size 4030 = VA          12.7x10.2x6 Size 5040 = YA          15.3x13.7x7 Size 6054 = YA          2.5x7x4.6 PCM2.5 = 0B          3x7.5x4.6 PCM2.5 = 0C          2.5x6.5x7.2 PCM5 = 1A          3x7.5x7.2 PCM5 = 1B          2.5x7x10 PCM7.5 = 2A          3x8.5x10 PCM7.5 = 2B          3x9x13 PCM10 = 3A          4x9x13 PCM10 = 3C          5x11x18 PCM15 = 4B          6x12.5x18 PCM15 = 4C          5x14x26.5 PCM22.5 = 5A          6x15x26.5 PCM22.5 = 5B          9x19x31.5 PCM27.5 = 6A          11x21x31.5 PCM27.5 = 6B          9x19x41.5 PCM37.5 = 7A          11x22x41.5 PCM37.5 = 7B          19x31x56 PCM 48.5 = 8D          25x45x57 PCM 52.5 = 9D          ...</p>	<p><b>Tolerance:</b></p> <p>±20% = M          ±10% = K          ±5% = J          ±2.5% = H          ±1% = E          ...</p> <p><b>Packing:</b></p> <p>AMMO H16.5 340x340 = A          AMMO H16.5 490x370 = B          AMMO H18.5 340x340 = C          AMMO H18.5 490x370 = D          REEL H16.5 360 = F          REEL H16.5 500 = H          REEL H18.5 360 = I          REEL H18.5 500 = J          ROLL H16.5 = N          ROLL H18.5 = O          BLISTER W12 180 = P          BLISTER W12 330 = Q          BLISTER W16 330 = R          BLISTER W24 330 = T          Bulk/TPS Standard = S          ...</p>
			<p><b>Version code:</b></p> <p>Standard = 00          Version A1 = 1A          Version A1.1.1 = 1B          Version A2 = 2A          ...</p>	<p><b>Pin length (untaped)</b></p> <p>3.5 ±0.5 = C9          6 -2 = SD          16 ±1 = P1          ...</p> <p><b>Pin length (taped)</b></p> <p>none = 00</p>

The data on this page is not complete and serves only to explain the part number system. Part number information is listed on the pages of the respective WIMA range.